



**SPECIFICATION
FOR
LCD Module
PV05712T0231N-CO**

MODULE:	PV05712T0231N-CO
CUSTOMER:	

Kingtech	INITIAL	DATE
PREPARED BY	杨荣武	20211113
CHECKED BY	陈志文	20211113
APPROVED BY	罗教平	20211113

CUSTOMER	INITIAL	DATE
APPROVED BY		



REVISION STATUS

Version	Revise Date	Page	Content	Modified by
V1.0	20211113	-	First Issued.	YANG



TABLE OF CONTENTS

- 1.General Description
2. Mechanical Characteristics
3. Pin Description
4. Electrical Characteristics
5. Optical Characteristics
6. Quality Specifications
7. Reliability
8. Handling Precaution



1. General Description

* DESCRIPTION

PV05712T0231N-CO is a color active matrix TFT (Thin Film Transistor) LCD (liquid crystal display) that uses amorphous silicon TFT as a switching device. This model is composed of a Transmissive type TFT-LCD Panel, driver circuit, back-light unit . The resolution of a 5.7" TFT-LCD contains 1080 x 1920 pixels, and can display up to 16.7M colors.

* Features

- Low Input Voltage: IOVCC: 1.65~3.3V;VCC: 2.5~3.3V
- Display Colors of TFT LCD: 16.7M colors
- Interface: MIPI-4 Lanes
- Internal Power Supply Circuit.

General Information Items	Specification	Unit	Note
	Main Panel		
Display area(AA)	64.8(H) *129.6(V)	mm	-
Driver element	a-Si TFT active matrix	-	-
Display colors	16.7M	colors	-
Number of pixels	720(RGB) *1440	dots	-
Pixel arrangement	RGB vertical stripe	-	-
Pixel pitch	30 (H) *90(V)	um	-
Viewing angle	All	o'clock	-
Drive IC	ST7703	-	-
Display mode	Normally black	-	-
Operating temperature	-20~+70	°C	-
Storage temperature	-30~+80	°C	-

Mechanical Information

Item		Min.	Typ.	Max.	Unit	Note
Module size	Horizontal(H)	-	72.75	-	mm	±0.05
	Vertical(V)	-	152.18	-	mm	±0.05
	Depth(D)	-	2.72	-	mm	±0.3
Weight		-	TBD	-	g	-



3.Pin Description

Pin NO.	Symbol	Level	Remark
1	VCC(2.8V)	H	A supply voltage
2	CTP-VCC(2.8V)	H	A supply voltage
3	IOVCC(1.8V)	H	A supply voltage
4	IOVCC(1.8V)	H	A supply voltage
5	TP-INT	H/L	Interrupt pin
6	TP-RST	H/L	Hardware reset pin
7	TP-SDA	H/L	Serial data input pin
8	TP-SCL	H/L	Serial data input pin
9	LCD_ID	H/L	LCD ID pin
10	LCD-RST	H/L	Hardware reset pin
11	TE	L	
12	LEDK	L	Backlight Cathode
13	LEDK	L	Backlight Cathode
14	LED_A	H	Backlight Anode
15	LED_A	H	Backlight Anode
16	GND	L	Ground
17	D3_N	H/L	MIPI_DP3- are differential data signal line
18	D3_P	H/L	MIPI_DP3+ are differential data signal line
19	GND	L	Ground
20	D0_N	H/L	MIPI_DP0- are differential data signal line
21	D0_P	H/L	MIPI_DP0+ are differential data signal line
22	GND	L	Ground
23	D1_N	H/L	MIPI_DP1- are differential data signal line
24	D1_P	H/L	MIPI_DP1+ are differential data signal line
25	GND	L	Ground
26	D2_N	H/L	MIPI_DP2- are differential data signal line
27	D2_P	H/L	MIPI_DP2+ are differential data signal line
28	GND	L	Ground
29	CLK_P	H/L	CLOCK Lane Pegative-end input pin
30	CLK_N	H/L	CLOCK Lane nositive-end input pin
31	GND	L	Ground



4. ELECTRICAL CHARACTERISTICS

4.1 ABSOLUTE MAXIMUM RATINGS

Item	Symbol	Values		Unit	Remark
		Min	Max.		
Supply Voltage for Logic circuit	VDDIO	1.65	3.3	V	
Supply Voltage for analog circuit	Vcc	2.5	3.3	V	

4.2 DC ELECTRICAL CHARACTERISTICS

4.2.1 OPERATING CONDITIONS

Typical Operating Conditions (Ta=25°C)

Item	Symbol	Values			Unit	Remark
		Min	Typ	Max.		
Power Supply	Vcc	2.5	2.8	3.3	V	
Power Supply	VDDIO	1.65	1.8	3.3	V	
Normal mode Current consumption	Icc	-	-	-	mA	VCC=2.8V
TFT Gate ON Voltage	VGH		16	-	V	
TFT Gate OFF Voltage	VGL		-12		V	

4.2.2 BACKLIGHT UNIT (GND=0V)

Item	Symbol	Values			Unit	Remark
		Min	Typ	Max.		
Forward supply Voltage	Vf	20.3	-	23.8	V	
Forward supply Current	If	-	40	-	mA	
LCM Luminance	L _V	350	400	-	cd/m ²	I _B =40mA
Uniformity	/	80			%	-



4.3 MIPI Interface Characteristics

5.6.1 Case 1: RESX line is held high or unstable by host at power on

If RESX line is held high or unstable by the host during power on, then a Hardware Reset must be applied after both VDD1, VDD2 and VDD3 have been applied - otherwise correct functionality is not guaranteed. There is no timing restriction upon this hardware reset.

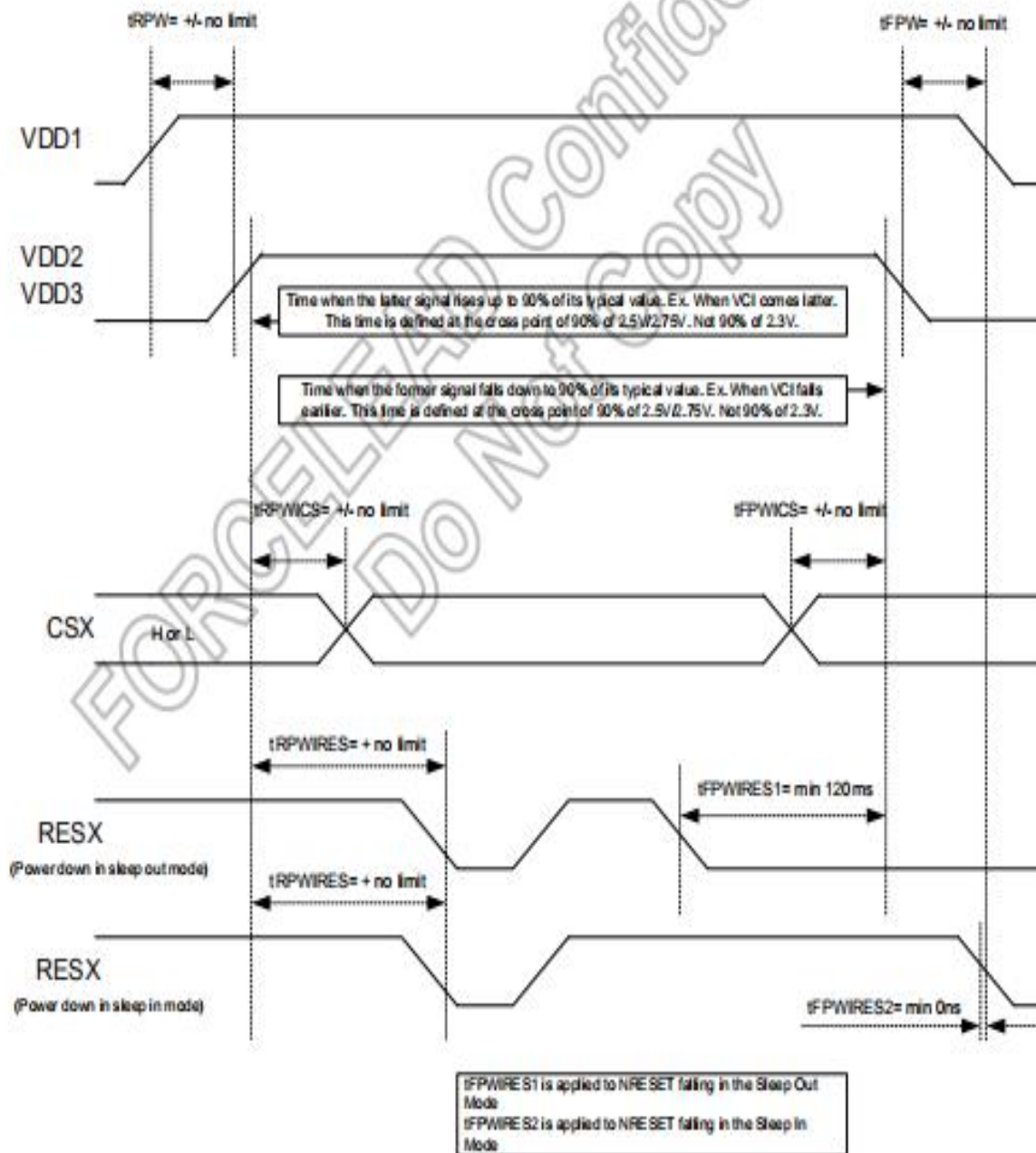
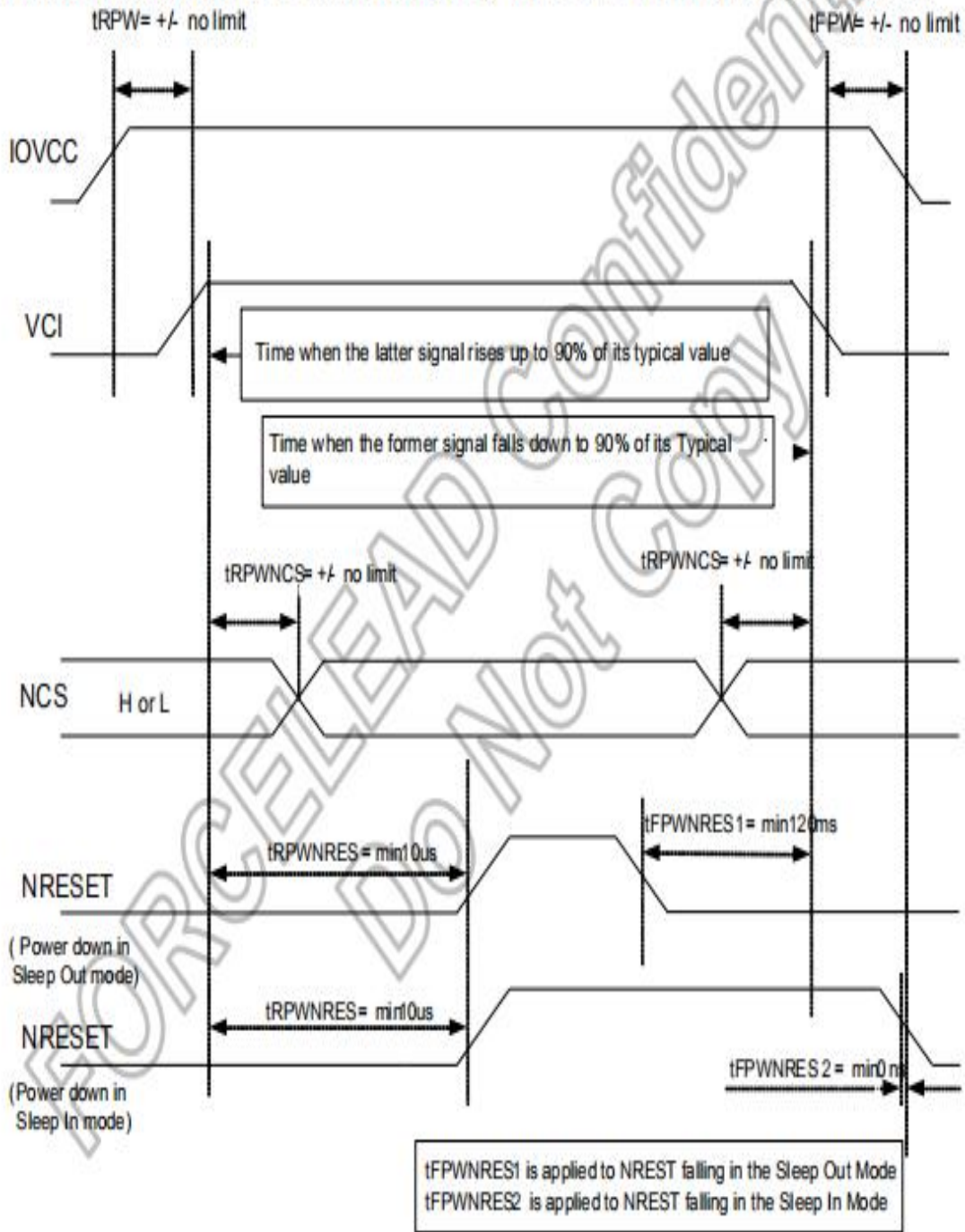

Figure 5.33: Case 1: RESX line is held high or unstable by host at power on



5.6.2 Case 2: RESX line is held low by host at power on

If RESX line is held low (and stable) by the host during power on, then the RESX must be held low for minimum 10μsec after both VDD1, VDD2 and VDD3 have been applied.



Note: Unless otherwise specified timings herein show cross point at 50% of signal/power level



7.3.2 DSI Interface Timing Characteristics

High Speed Mode

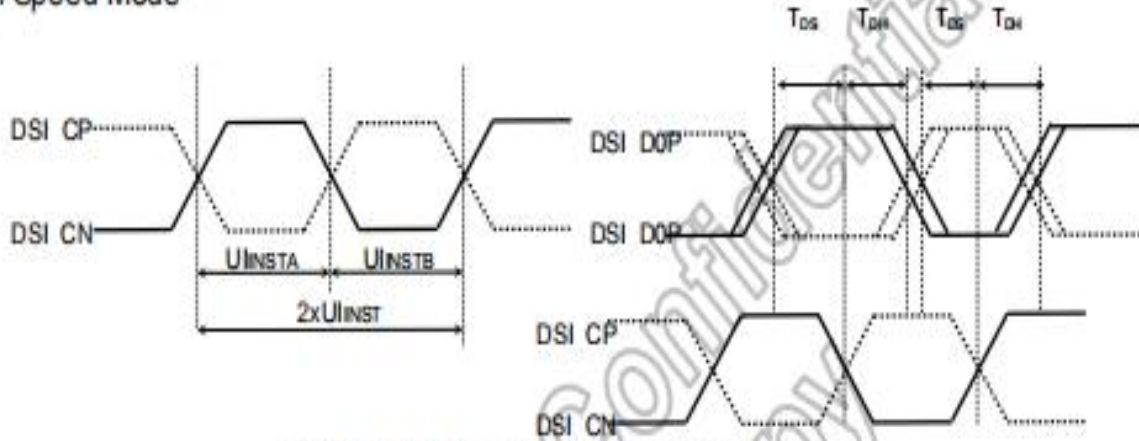

Figure 7.4: DSI clock timing Characteristics

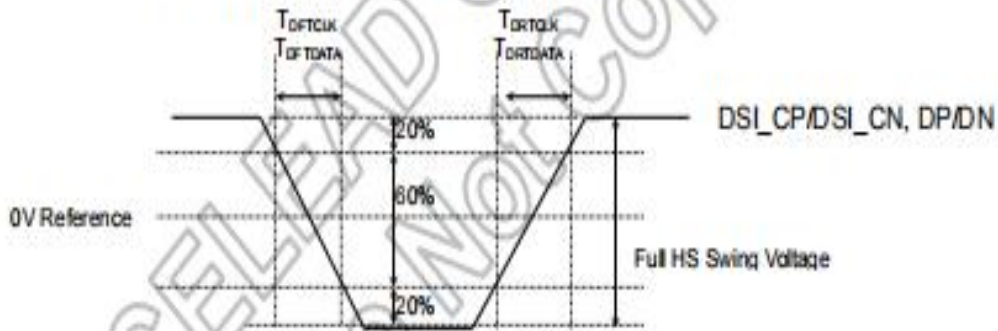

Figure 7.5: Rising and falling time on clock and data channel

(VSSA=0V, IOVCC=1.65V to 3.3V, VCI=2.5V to 3.3V, T_A = -30 to 70°C)

Signal	Item	Symbol	Spec.			Unit
			Min.	Typ.	Max.	
DSI_CP/ DSI_CN	Double UI instantaneous	2xU _{INST}	TBD	-	25	ns
	UI instantaneous	U _{INSTA} U _{INSTB}	TBD	-	12.5	ns
DP/DN	Data to clock setup time	T _{DS}	0.15xUI	-	-	ps
	Data to clock hold time	T _{DH}	0.15xUI	-	-	ps
DSI_CP/ DSI_CN	Differential rise time for clock	T _{DRTCLK}	150	-	0.3UI	ps
	Differential fall time for clock	T _{DFTCLK}	150	-	0.3UI	ps
DP/DN	Differential rise time for data	T _{DRTDATA}	150	-	0.3UI	ps
	Differential fall time for data	T _{DFTDATA}	150	-	0.3UI	ps

Table 7.3: DSI High Speed Mode Characteristics



5. OPTICAL CHARACTERISTICS (LCD MONOMER PARAMETERS)

6. OPTICAL SPECIFICATION (light source: C light)

Item	Symbol	Conditions	Specifications			Unit	Note	
			Min.	Typ.	Max.			
Transmittance (w/o DBEF)	T%	Viewing normal angle $\theta_x = \theta_y = 0^\circ$	3.79	4.46	--	%	All left side data are based on INX's following condition – 1.LC : AAS . 2.Light Source : C-light 3.Polarizer : CF: GRT1794XH1UHC3 TFT: CMT1794FDUHC3 4.Machine : DMS 803, (ConoScope for View Angle). 5. VLC dark ≤ 0.3 V VLC white ≥ 5.4 V	
Contrast Ratio(without WOTP)	CR		1200	1500	--	--		
Response Time	$T_{on} + T_{off}$		-	30	35	ms		
Viewing Angle	Hor.	θ_{x+}		80	--	deg.		
		θ_{x-}		80	--			
	Ver.	θ_{y+}		80	--			
		θ_{y-}		80	--			
CF only Color Chromaticity (CIE 1931)	Red	Rx	0.643	0.663	0.683	-		Under C light (CIE 1931)
		Ry	0.305	0.325	0.345	-		
	Green	Gx	0.256	0.276	0.296	-		
		Gy	0.552	0.572	0.592	-		
	Blue	Bx	0.119	0.139	0.159	-		
		By	0.068	0.088	0.108	-		
	White	Wx	0.281	0.301	0.321	-		
		Wy	0.308	0.328	0.348	-		
Color Gamut	CG		70	--	%			

*Note(1) Definition of Contrast Ratio (CR):

The contrast ratio can be calculated by the following expression.

$$\text{Contrast Ratio (CR)} = L_{255} / L_0$$

L255 : Luminance of gray level 255

L 0: Luminance of gray level 0

$$CR = CR (5)$$

CR (X) is corresponding to the Contrast Ratio of the point X at Figure in Note (5).



*Note (2) Definition of Response Time (T_{on} , T_{off}):

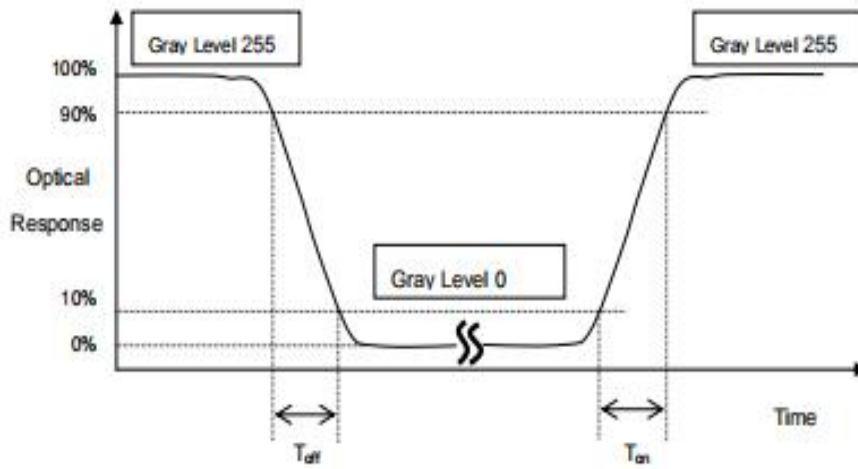

*Note(3) Definition of Viewing Angle

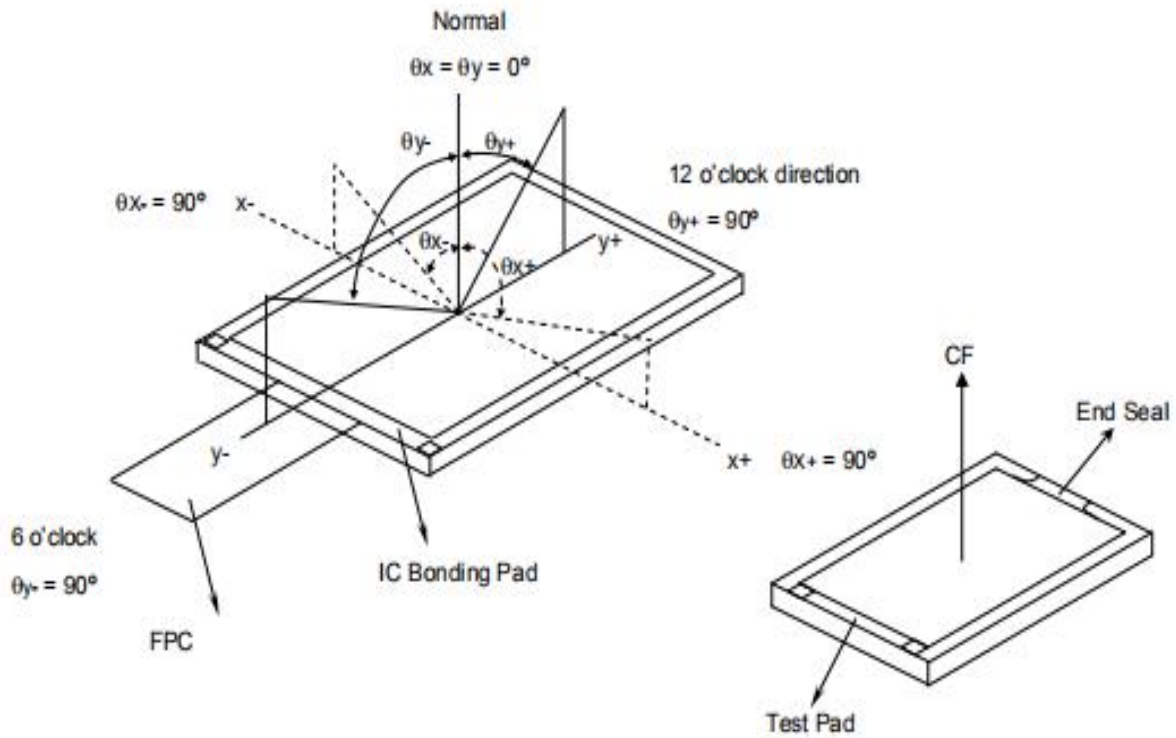



***Note (4) Measurement Set-Up:**

The LCD module should be stabilized at a given temperature for 20 minutes to avoid abrupt temperature change during measuring. In order to stabilize the luminance, the measurement should be executed after lighting Backlight for 20 minutes in a windless room.

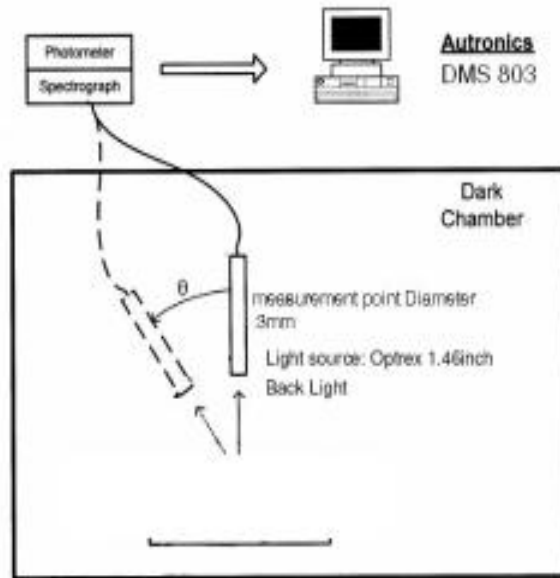

***Note (5)**

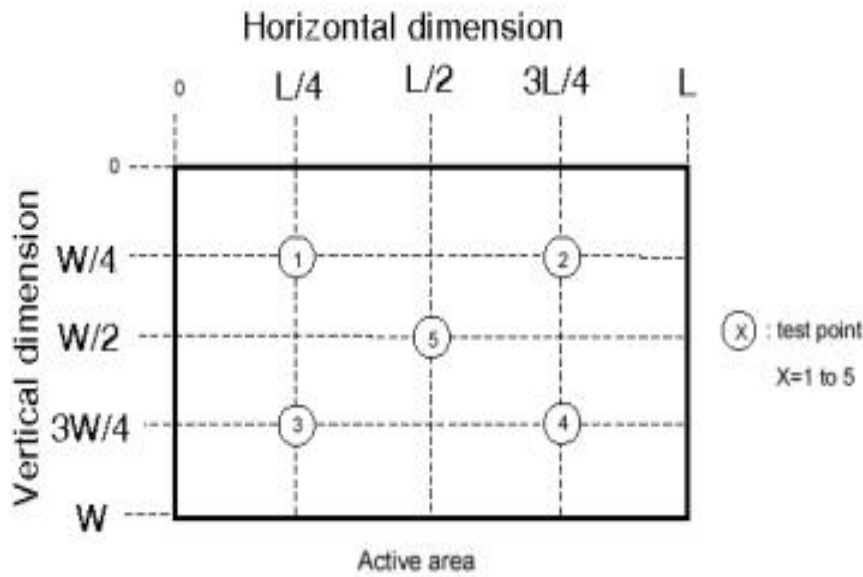



6. QUALITY SPECIFICATIONS

1. Inspection condition

1.1:Cosmetic inspection: viewing distance is about 30cm with bare eyes, and under an environment of 20~40W light intensity (600~1200LUX) , all directions for inspecting the sample should be within 45° against perpendicular line.

6.1.2:Function inspection: viewing distance is about 30cm with bare eyes, and under an environment of 300LUX light intensity, all directions for inspecting the sample should be within 45° against perpendicular line.

2. Definition of Inspection Item.

2.1 Definition of Inspection zone in I-touch module.

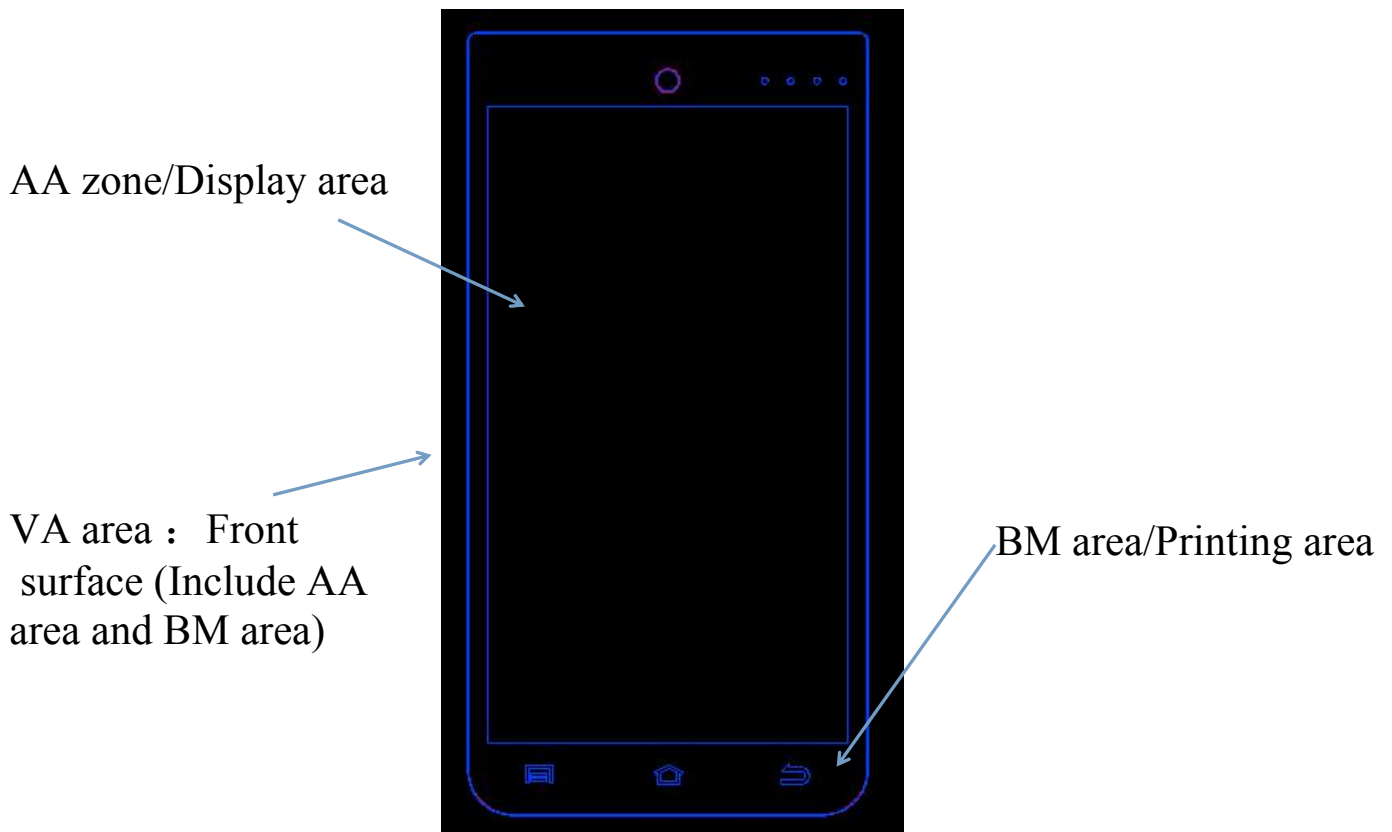

AA zone: Character/Display area

BM zone: Printing area

VA zone: Viewing area (AA area + BM area = viewing area)



3. Defect definition

3.1 Circular defect

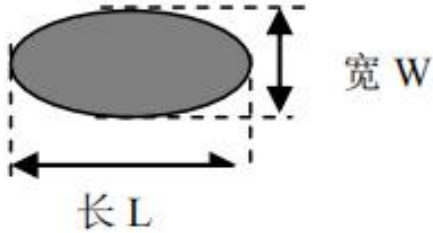

Diameter $\Phi = 1/2(L+W)$

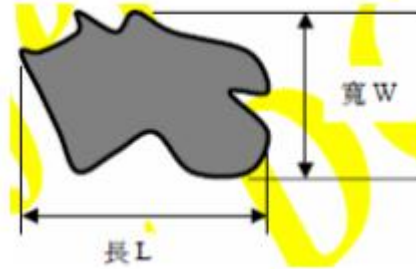

Diameter $\Phi = 1/2(L+W)$

3.2 Linear defect

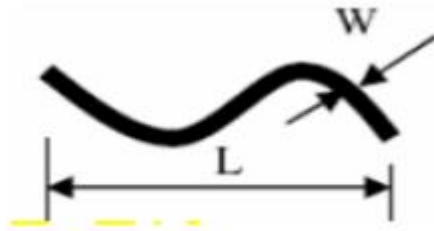

3.3 Pin hole

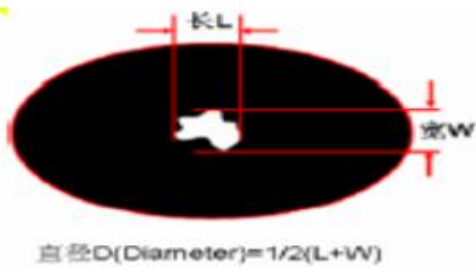

直径D(Diameter) = $1/2(L+W)$

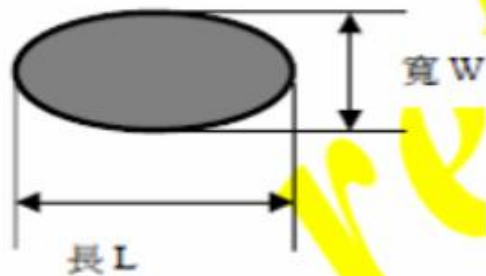

3.4 Zigzag

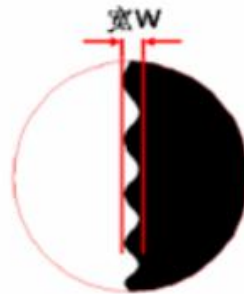



4. Inspection standards

4.1 Major defect

-Item -No	Items to be inspected	Inspection Standard	Classification of defects
4.1.1	All functional defects	1) No display 2) Display abnormally 3) Missing vertical, horizontal segment 4) Short circuit 5) Back-light no lighting, flickering and abnormal lighting. 6) Touch panel abnormal.	Major
4.1.2	Missing	Missing component	
4.1.3	Outline dimension	Overall outline dimension beyond the drawing is not allowed.	
4.1.4	LCD Mura	LCD Mura according to ND 5% keep out to determine, if keep out distance at 30cm be seen by eyes is NG, otherwise will be ok if invisible.	

4.2 Cosmetic defect

Item No	Items to be inspected	Inspection Standard	Classification of defects												
4.2.1	Dot defect	<table border="1"> <thead> <tr> <th>Zone</th> <th>VA area</th> </tr> </thead> <tbody> <tr> <td>Size(mm)</td> <td>Acceptable Qty</td> </tr> <tr> <td>$\Phi \leq 0.1$</td> <td>Ignore</td> </tr> <tr> <td>$0.10 < \Phi \leq 0.25$</td> <td>2</td> </tr> <tr> <td>$0.25 < \Phi \leq 0.30$</td> <td>1</td> </tr> <tr> <td>$0.30 < \Phi$</td> <td>0</td> </tr> </tbody> </table>	Zone	VA area	Size(mm)	Acceptable Qty	$\Phi \leq 0.1$	Ignore	$0.10 < \Phi \leq 0.25$	2	$0.25 < \Phi \leq 0.30$	1	$0.30 < \Phi$	0	Minor
		Zone	VA area												
		Size(mm)	Acceptable Qty												
		$\Phi \leq 0.1$	Ignore												
		$0.10 < \Phi \leq 0.25$	2												
		$0.25 < \Phi \leq 0.30$	1												
$0.30 < \Phi$	0														



4.2.2	Dim Spots: Circle shaped and dim edged defects	<table border="1"> <thead> <tr> <th colspan="2">Zone</th> <th>VA area</th> </tr> <tr> <th colspan="2">Size(mm)</th> <th>Acceptable Qty</th> </tr> </thead> <tbody> <tr> <td colspan="2">$\Phi \leq 0.20$</td> <td>Ignore</td> </tr> <tr> <td colspan="2">$0.20 < \Phi \leq 0.40$</td> <td>2</td> </tr> <tr> <td colspan="2">$0.40 < \Phi \leq 0.60$</td> <td>1</td> </tr> <tr> <td colspan="2">$0.60 < \Phi$</td> <td>0</td> </tr> </tbody> </table>	Zone		VA area	Size(mm)		Acceptable Qty	$\Phi \leq 0.20$		Ignore	$0.20 < \Phi \leq 0.40$		2	$0.40 < \Phi \leq 0.60$		1	$0.60 < \Phi$		0	Minor			
Zone		VA area																						
Size(mm)		Acceptable Qty																						
$\Phi \leq 0.20$		Ignore																						
$0.20 < \Phi \leq 0.40$		2																						
$0.40 < \Phi \leq 0.60$		1																						
$0.60 < \Phi$		0																						
Item No	Items to be inspected	Inspection Standard	Classification of defects																					
4.2.3	Dent Spot Fish eye	<table border="1"> <thead> <tr> <th colspan="2">Zone</th> <th>VA area</th> </tr> <tr> <th colspan="2">Size(mm)</th> <th>Acceptable Qty</th> </tr> </thead> <tbody> <tr> <td colspan="2">$\Phi \leq 0.10$</td> <td>Ignore</td> </tr> <tr> <td colspan="2">$0.10 < \Phi \leq 0.20$</td> <td>2</td> </tr> <tr> <td colspan="2">$0.20 < \Phi \leq 0.30$</td> <td>1</td> </tr> <tr> <td colspan="2">$0.30 < \Phi$</td> <td>0</td> </tr> </tbody> </table>	Zone		VA area	Size(mm)		Acceptable Qty	$\Phi \leq 0.10$		Ignore	$0.10 < \Phi \leq 0.20$		2	$0.20 < \Phi \leq 0.30$		1	$0.30 < \Phi$		0	Minor			
Zone		VA area																						
Size(mm)		Acceptable Qty																						
$\Phi \leq 0.10$		Ignore																						
$0.10 < \Phi \leq 0.20$		2																						
$0.20 < \Phi \leq 0.30$		1																						
$0.30 < \Phi$		0																						
4.2.4	Line defect	<table border="1"> <thead> <tr> <th colspan="2">Zone</th> <th>VA area</th> </tr> <tr> <th colspan="2">Size(mm)</th> <th>Acceptable Qty</th> </tr> <tr> <th>L (Length)</th> <th>W (Width)</th> <th></th> </tr> </thead> <tbody> <tr> <td>Ignore</td> <td>$W \leq 0.03$</td> <td>Ignore</td> </tr> <tr> <td>$L \leq 5.0$</td> <td>$0.03 < W \leq 0.05$</td> <td>2</td> </tr> <tr> <td>$L \leq 3.0$</td> <td>$0.05 < W \leq 0.07$</td> <td>1</td> </tr> <tr> <td>/</td> <td>$0.07 < W$</td> <td>Define as spot defect</td> </tr> </tbody> </table>	Zone		VA area	Size(mm)		Acceptable Qty	L (Length)	W (Width)		Ignore	$W \leq 0.03$	Ignore	$L \leq 5.0$	$0.03 < W \leq 0.05$	2	$L \leq 3.0$	$0.05 < W \leq 0.07$	1	/	$0.07 < W$	Define as spot defect	Minor
Zone		VA area																						
Size(mm)		Acceptable Qty																						
L (Length)	W (Width)																							
Ignore	$W \leq 0.03$	Ignore																						
$L \leq 5.0$	$0.03 < W \leq 0.05$	2																						
$L \leq 3.0$	$0.05 < W \leq 0.07$	1																						
/	$0.07 < W$	Define as spot defect																						



4.2.5	Scratch	<p>If the scratch can be seen after mobile phone cover assembling or in the operating condition, judged as the line defect of 4.2.4.</p> <p>If the scratch can be seen only in non-operating condition or some special angle, judged as the following table.</p> <table border="1"> <thead> <tr> <th colspan="2">Size (mm)</th> <th>VA area</th> </tr> <tr> <th>L (Length)</th> <th>Acceptable Qty</th> <th>Acceptable Qty</th> </tr> </thead> <tbody> <tr> <td>Ignore</td> <td>$W \leq 0.03$</td> <td>Ignore</td> </tr> <tr> <td>$5.0 < L \leq 10.0$</td> <td>$0.03 < W \leq 0.05$</td> <td>2</td> </tr> <tr> <td>$L \leq 5.0$</td> <td>$0.05 < W \leq 0.08$</td> <td>1</td> </tr> <tr> <td>/</td> <td>$W > 0.08$</td> <td>0</td> </tr> </tbody> </table>	Size (mm)		VA area	L (Length)	Acceptable Qty	Acceptable Qty	Ignore	$W \leq 0.03$	Ignore	$5.0 < L \leq 10.0$	$0.03 < W \leq 0.05$	2	$L \leq 5.0$	$0.05 < W \leq 0.08$	1	/	$W > 0.08$	0	Minor
Size (mm)		VA area																			
L (Length)	Acceptable Qty	Acceptable Qty																			
Ignore	$W \leq 0.03$	Ignore																			
$5.0 < L \leq 10.0$	$0.03 < W \leq 0.05$	2																			
$L \leq 5.0$	$0.05 < W \leq 0.08$	1																			
/	$W > 0.08$	0																			



Item No	Items to be inspected	Inspection Standard	Classification of defect										
4.2.6	Bubble	<table border="1"> <thead> <tr> <th>Zone</th> <th>VA area</th> </tr> <tr> <th>Size(mm)</th> <th>Acceptable Qty</th> </tr> </thead> <tbody> <tr> <td>$\Phi \leq 0.15$</td> <td>Ignore</td> </tr> <tr> <td>$0.15 < \Phi \leq 0.25$</td> <td>2</td> </tr> <tr> <td>$0.25 < \Phi$</td> <td>0</td> </tr> </tbody> </table>	Zone	VA area	Size(mm)	Acceptable Qty	$\Phi \leq 0.15$	Ignore	$0.15 < \Phi \leq 0.25$	2	$0.25 < \Phi$	0	
Zone	VA area												
Size(mm)	Acceptable Qty												
$\Phi \leq 0.15$	Ignore												
$0.15 < \Phi \leq 0.25$	2												
$0.25 < \Phi$	0												
4.2.7	Glass defect	<p>4.2.7a Chip on corner or surface</p> <table border="1"> <thead> <tr> <th>L(length)</th> <th>W(width)</th> <th>Z(thickness)</th> </tr> </thead> <tbody> <tr> <td>$L \leq 0.30$</td> <td>$W \leq 0.20$</td> <td>T/2</td> </tr> </tbody> </table> <p>Notes: T=Lens thickness, $\Phi \leq 0.10$ ignore Acceptable Qty: Single edge $N \leq 2$, Total $N \leq 4$</p> <p>4.2.7b Cracks Cracks tend to break are not allowed.</p>	L(length)	W(width)	Z(thickness)	$L \leq 0.30$	$W \leq 0.20$	T/2	Minor				
L(length)	W(width)	Z(thickness)											
$L \leq 0.30$	$W \leq 0.20$	T/2											
Item No	Items to be inspected	Inspection Standard	Classification of defect										



4.2.8	Parts alignment	1) Not allow IC and FPC/heat-seal lead width is more than 50% beyond lead pattern. 2) Not allow chip or solder component is off center more than 50% of the pad outline.	Minor
4.2.9 view area/ printing area of front surface and view area of rear surface	LOGO Pattern	 <p>Dot: according to Dot spec. Thickness odds:</p> $\frac{ \text{Spec pattern width} - \text{Print pattern width} \times 100\%}{\text{Spec pattern width}} \leq 30\%$ <p>Drawing slant:</p> Print pattern length $\leq 10\text{mm}$, slant angle $\leq 3^\circ$; $10\text{mm} < \text{Print pattern length} \leq 20\text{mm}$, slant angle $\leq 1.5^\circ$	Minor



Item No	Items to be inspected	Inspection Standard	Classification of defects
---------	-----------------------	---------------------	---------------------------



4.2.10 view area/print ing area of front surface and view area of rear surface	IR hole(A)/ Light sensor hole(B)/ LED hole(C)		Minor
		<ol style="list-style-type: none"> 1. A.B.C hole must be according the transmittancy 2. Light leakage on A.B.C hole or follow the limited sample. 3. A.B.C hole (LED) hole only judge by black background, no need to check in the lamb condition. 	
	Surface dirty	<ol style="list-style-type: none"> 1. Dirty can not be cleaned follow the dot spec. 2. Accept while the dirty can be cleaned. 3. The quality guarantee period of protective film is 3months, during the period, the spot or contamination is not allowed. 	
	Printing area Light leakage	Follow the dot defect spec, MAX, Severity - see light leakage limit sample	
	Ink overflow	Visual inspection 30cm not allowed	
	Color discordant	Obvious color difference in the BM area is not allowed	
Icon scratch of printing logo area	Icon printing logo area is not allow penetrability scratch		



7. RELIABILITY

Test Item	Test Condition
High Temperature Operation	70°C for 96 hours
Low Temperature Operation	-20°C for 96 hours
High Temperature Storage	80°C for 96 hours
Low Temperature Storage	-30°C for 96 hours
High Temperature Operation Humidity Operation	60°C, 90%RH for 72 hours
Thermal Shock	-10°C (30min) ~ +25°C (5min) ~ +60°C (30min) for 10 cycles
Vibration Test (No Operation)	Frequency: 10~55Hz Amplitude:1.0mm Sweep Time: 11min Test Period: 6 Cycles for each direction of X, Y, Z
Static electricity test	Touch 4KV, air touch 8KV



8. HANDLING PRECAUTION

8.1 SAFETY

- (1) Do not swallow any liquid crystal, even if there is no proof that liquid crystal is poisonous.
- (2) If the LCD panel breaks, be careful not to get liquid crystal to touch your skin.
- (3) If skin is exposed to liquid crystal, wash the area thoroughly with alcohol or soap.

8.2 STORAGE CONDITIONS

- (1) Store the panel or module in a dark place where the temperature is $23\pm 5^{\circ}\text{C}$ and the humidity is below $50\pm 20\% \text{RH}$.
- (2) Store in anti-static electricity container.
- (3) Store in clean environment, free from dust, active gas, and solvent.
- (4) Do not place the module near organics solvents or corrosive gases.
- (5) Do not crush, shake, or jolt the module.

8.3 HANDLING PRECAUTIONS

- (1) Avoid static electricity which can damage the CMOS LSI.
- (2) The polarizing plate of the display is very fragile. So, please handle it very carefully.
- (3) Do not give external shock.
- (4) Do not apply excessive force on the surface.
- (5) Do not wipe the polarizing plate with a dry cloth, as it may easily scratch the surface of plate.
- (6) Do not use ketonic solvent & Aromatic solvent, use with a soft cloth soaked with a cleaning naphtha solvent.
- (7) Do not operate it above the absolute maximum rating.
- (8) Do not remove the panel or frame from the module.

8.4 WARRANTY

- 1) The period is within twelve months since the date of shipping out under normal using and storage conditions.
- 2) According to Kingtech TFT LCD quality standard, Kingtech will rework or exchange for functional defect goods since within one year.