



Display Module SPECIFICATION

Model: PV05710W0233L

Customer	
Customer NO.	
Approve By	

For Solution ---5.7 inch ;320(W)XRGBX240(H)

Owner:

Version: V01

Document ID: PV05710W0233L

Approved by



Record of Revisions

Rev	Date	Sub-Model	Description of change
V01	Nov. 21 th 2022	PV05710W0233L	Preliminary Product Specification was first issued.



Table of contents

1. General description

2. Absolute maximum ratings

3. Optical characteristics

4. Block diagram

5 Interface pin connection

6. Electrical characteristics

7. Reliability test items

8. Outline dimension

9. General precaution

10. Package Specification

11. Visuals Specification:



1. General description

1.1 Introduction

Kingtech PV05710W0233L is a color active matrix thin film transistor (TFT) liquid crystal display (LCD) that uses amorphous silicon TFT as a switching device. This model is composed of a TFT LCD panel, a driving circuit and a back light system. This TFT LCD has a 5.7 (4:3) inch diagonally measured active display area with QVGA (320 horizontal by 240 vertical pixel) resolution.

1.2 Features

5.7(4:3 diagonal) inch configuration

18 bits TTL interface

LED Backlight

Up/Down, Left/Right reversion selection

RoHS Compliance

1.3 Applications

Mobile NB,GPS

Personal Navigation Device

Multimedia applications and Others AV system

1.4 General information

Item	Specification	Unit
Outline Dimension	104.6x 144.0x 12.8(Typ.)	mm
Display area	115.2(H) x 86.4(V)	mm
Number of Pixel	320 RGB(H) x 240(V)	pixels
Pixel pitch	0.36(H) x 0.36(V)	mm
Pixel arrangement	RGB Vertical stripe	
Display mode	Normally white	
Surface treatment	Antiglare, Hard-Coating(3H) with EWV film	
Weight	200(Typ.)	g
Back-light	Single LED (Side-Light type)	
Power Consumption	2.5(Max.)	w

1.5 Mechanical Information

item		Min.	Typ.	Max.	Unit
Module Size	Horizontal(H)	104.3	104.6	104.9	mm
	Vertical(V)	143.7	144.0	144.3	mm
	Depth(D)	12.6	12.8	13.0	mm



2.0 ABSOLUTE MAXIMUM RATINGS

2.1 Electrical Absolute Rating

2.1.1 TFT LCD Module

Item	Symbol	Min.	Max.	Unit.	Note
Power supply voltage	VDD	-0.3	7.0	V	GND=0
	VGH	0.3	40	V	GND=0
	VGL	-20	0.3	V	GND=0
	AVDD	-0.3	7.0	V	AGND=0
	VCOM	0	6	V	
Logic Signal Input Level	V1	-0.3	VDD+0.3	V	

2.1.2 Back-Light Unit

Item	Symbol	MIN.	TYP.	MAX.	Unit	Note
Forward voltage	Vf	--	9.6	10.5	V	(1)(2)(3)
Forward current	If	--	200		mA	(1)(2)(3)
Power Consumption	PBL	--	1920		mW	

Note:

(1) Permanent damage may occur to the LCD module if beyond this specification. Functional operation should be restricted to the conditions described under normal operating conditions.

(2) $T_a = 25 \pm 2^\circ\text{C}$

(3) Test Condition: LED current 200 mA

2.2 Environment Absolute Rating

Item	Symbol	Min.	Max.	Unit	Remarks
Operating Temperature	Topa	-20	+70	°C	
Storage Temperature	Tstg	-30	+80	°C	



3.0 OPTICAL CHARACTERISTICS

3.1 Optical specification:

Item	Symbol	Temp.	Min.	Typ.	Max.	Unit	Condition
Response Time	Tr	25°C	--	15	--	msec	$\theta = 0^\circ, \phi = 0^\circ$ (Note 1,3)
	Tf	25°C	--	35	--		
Contrast Rate	Cr	25°C	150	250	--	--	$\theta = 0^\circ, \phi = 0^\circ$ LED:ON, LIGHT:OFF(Note1,2)
Brightness	YL	25°C	650	800		Cd/m2	(IL=200mA)(Note1,4)
Visual angle range front and rear	θ	25°C	(θ L) 65 (θ R)65			De-gree	$\phi = 0^\circ, CR \geq 10$ LED:ON LIGHT:OFF(Note 1,4)
Visual angle range left and right	θ	25°C	(θ U) 50 (θ D) 65			De-gree	$\phi = 90^\circ, CR \geq 10$ LED:ON LIGHT:OFF(Note 1,4)
Brightness uniformity	BUNI		75			%	$\Theta = 0$ (Note5,7)
Visual angle			6:00				(Note 6)
Item	Symbol	Transmissive			Conditions		
		Min.	Typ.	Max.			
Red	XR				Reference: LCD Panel, CIE (x, y) chromaticity (Note 1,4)		
	YR						
Green	XG						
	YG						
Blue	XB						
	YB						
White	XW	0.270	0.300	0.330			
	YW	0.290	0.320	0.350			

3.2 Measuring Condition

Measuring surrounding: dark room ,LED current IL : 200mA

Ambient temperature: 25±2oC

15min. warm-up time.

3.3 Measuring Equipment

FPM520 of Westar Display technologies, INC., which utilized SR-3 for Chromaticity and BM-5A for other optical characteristics. Measuring spot size: 20 ~ 21 mm



Note (1) Definition of Viewing Angle :

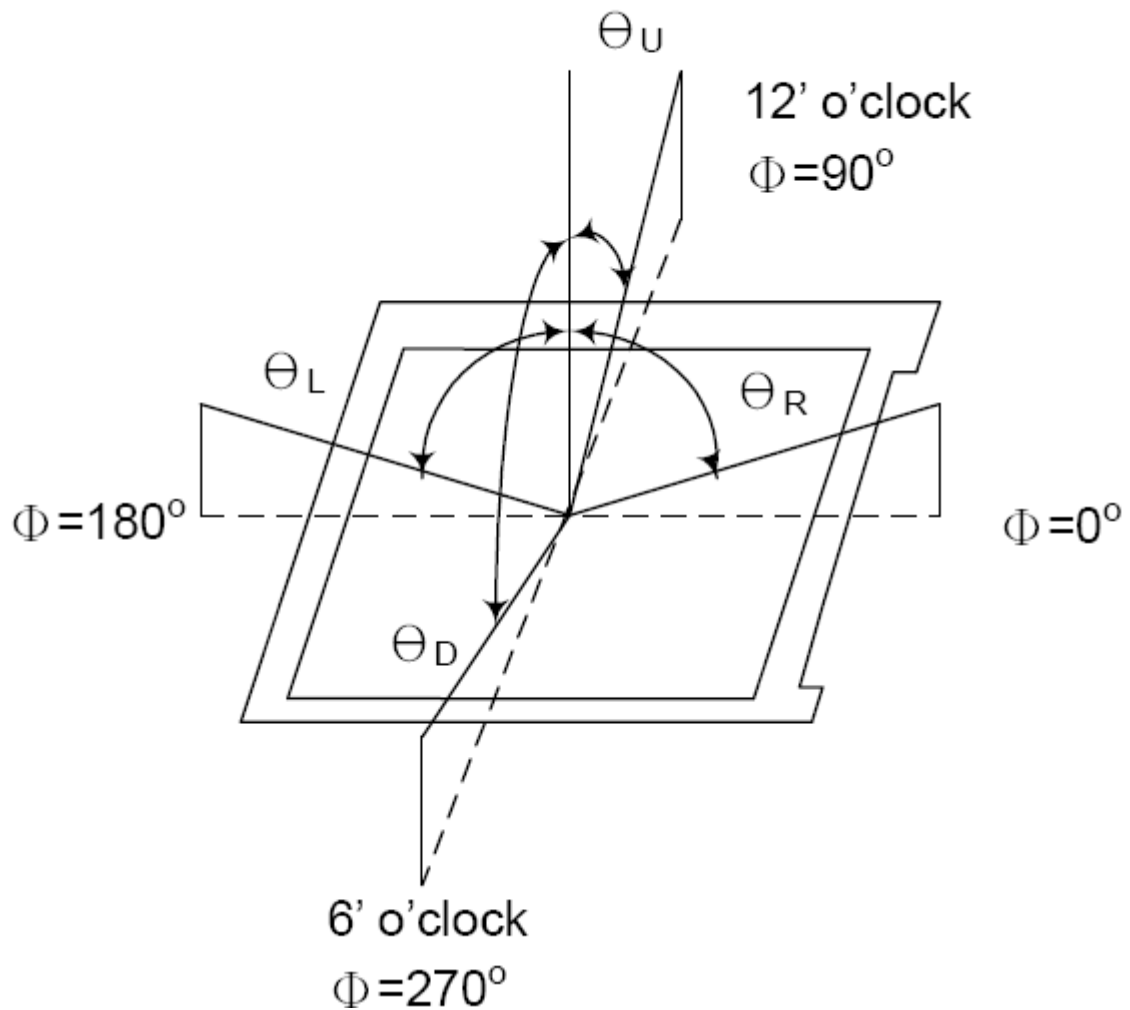

Note (2) Definition of Contrast Ratio (CR):

Measured at the center point of panel

$$CR = \frac{\text{Luminance with all pixels white}}{\text{Luminance with all pixels black}}$$

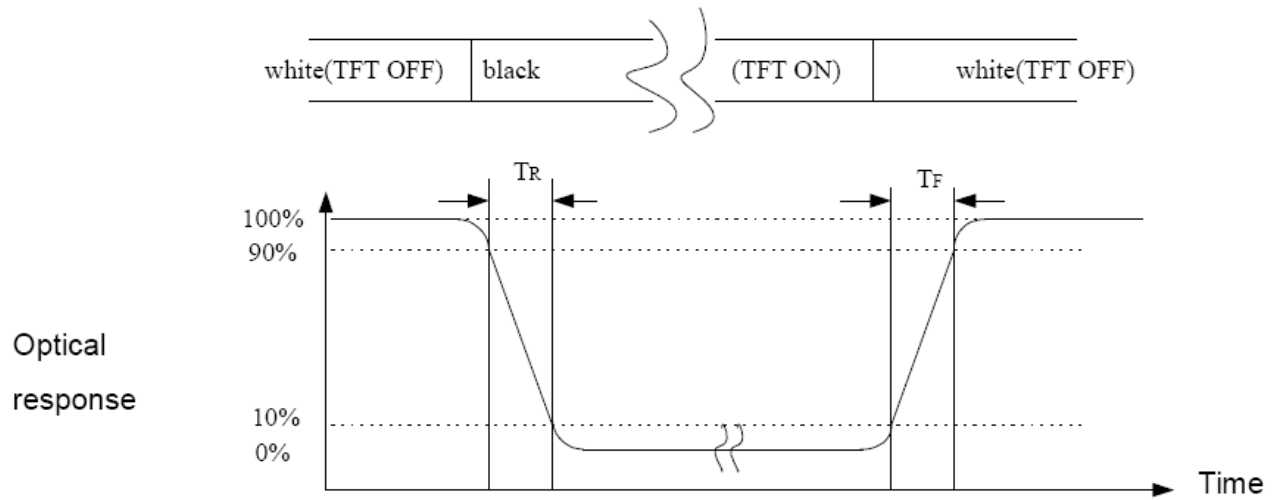
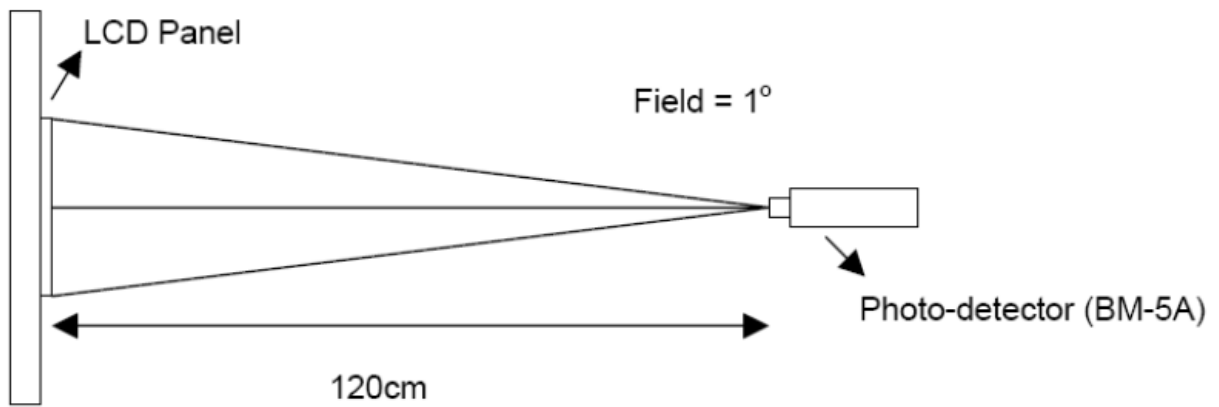
**Note (3) Definition of Response Time: Sum of TR and TF****Note (4) Definition of optical measurement setup**



Note (5) Definition of brightness uniformity

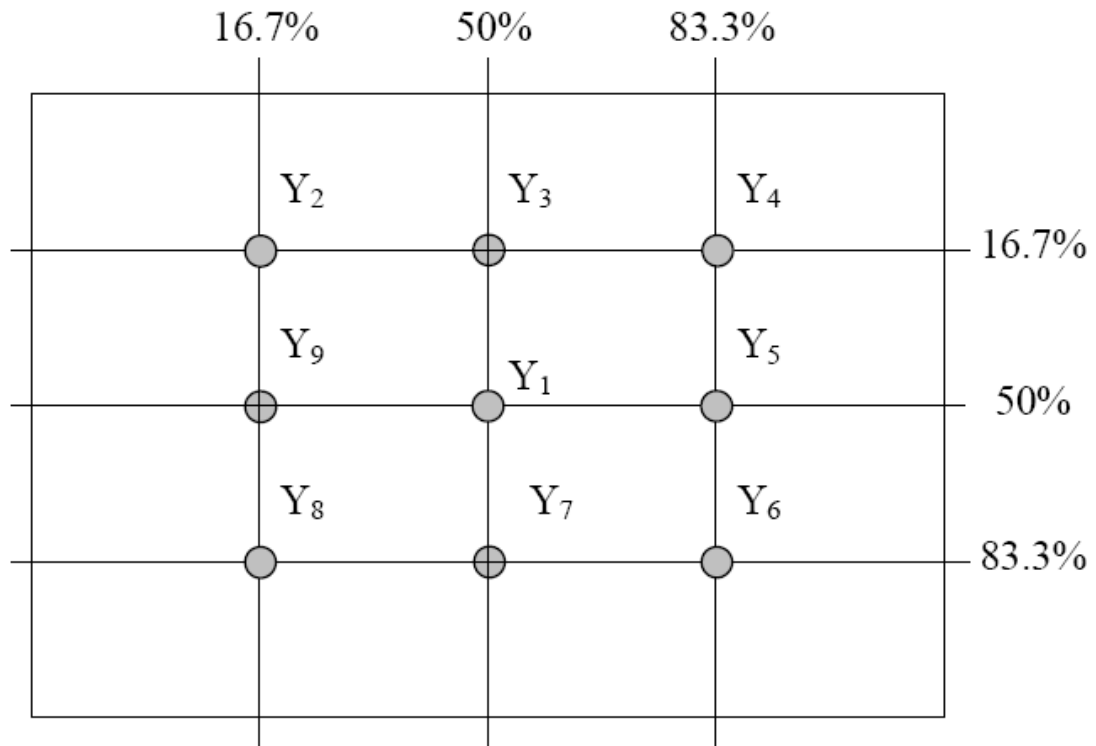

$$\text{Luminance uniformity} = \frac{(\text{Min Luminance of 9 points})}{(\text{Max Luminance of 9 points})} \times 100\%$$

Note (6) Rubbing Direction (The different Rubbing Direction will cause the different optimal view direction).

Note (7) Measured at the brightness of the panel when all terminals of LCD panel are electrically open.



5.0 INTERFACE PIN CONNECTION

5.1 TFT LCD ModuleCN2 (Input signal): FPC Down Connector: 5F2.2535E-A3821.133, or Equivalent 33pin.

Terminal No.	Symbol	IO	Functions
1	GND	P	Ground
2	DCLK	I	Sample clock
3	HS	I	Horizontal Sync Input
4	VS	I	Vertical Sync Input
5	GND	P	Ground
6	R0	I	Red data(LSB)
7	R1	I	Red data
8	R2	I	Red data
9	R3	I	Red data
10	R4	I	Red data
11	R5	I	Red data(MSB)
12	GND	P	Ground
13	G0	I	Green data (LSB)
14	G1	I	Green data
15	G2	I	Green data
16	G3	I	Green data
17	G4	I	Green data
18	G5	I	Green data(MSB)
19	GND	P	Ground
20	B0	I	Blue data(LSB)
21	B1	I	Blue data
22	B2	I	Blue data
23	B3	I	Blue data
24	B4	I	Blue data
25	B5	I	Blue data(MSB)
26	GND	P	Ground
27	DEN	I	Data Input Enable
28	VDD	P	Power for Digital Circuit
29	VDD	P	Power for Digital Circuit
30	LRC	I	Left / right selection
31	UDC	I	Up/down selection



32	NC	/	No connection
33	GND	P	Power Ground

Note: I:input O: output P: Power

5.2 Backlight Unit

CN2 LED Power Source (BHSR-02VS-1) or equivalent

Mating connector:(SBHT-002T-P0.5) or equivalent

Terminal NO.	Symbol	Function
1	VL	LED Power supply(High Voltage)
2	GL	LED Power supply(LOW Voltage)

K6.0 ELECTRICAL CHARACTERISTICS

Item	Symbol	Min.	Type	Max.	Unit.	Note
Power supply voltage	VDD	3.0	3.3	3.6	V	GND=0
	VGH	15.0	16.0	17.0	V	GND=0
	VGL	-6.0	-5.0	-4.0	V	GND=0
	AVDD	5.5	6.0/	6.5	V	AGND=0
	VIL	0	--	0.3VDD	V	GND=0
	VIH	0.7VDD	--	VDD	V	GND=0
	VCOM	--	4.5	--	V	GND=0
Power consumption	IVDD	--	520	600	mA	
Operation Temperature	Top	-20		70	°C	
Storage Temperature	Tst	-30		80	°C	
LED Reverse Voltage	Vr	-		(5)	V	Each LED
LED Forward Current	If	-		(35)	mA	Each LED

6.2 Back-Light Unit

The backlight system is an edge-lighting type with 30LED.

The characteristics of the LED are shown in the following tables.

Item	Symbol	Min.	Typ.	Max.	Unit	Note
LED current	IL	-	200	-	mA	(2)
LED Voltage	VL	--	9.6	10.5	V	
Operating LED life time	Hr	50000	-	-	Hour	(1)(2)

Note (1) LED life time (Hr) can be defined as the time in which it continues to operate under the condition: Ta=25±3 °C, typical IL value indicated in the above table until the brightness becomes less than 50%.

Note (2) The “LED life time” is defined as the module brightness decrease to 50% original brightness at Ta=25°C and IL=200mA. The LED lifetime could be decreased if operating IL is larger than 200mA. The constant current driving method is suggested



6.3 AC Characteristics

Signal	Parameter	Symbol	Min.	Typ.	Max.	Unit.	Note
DCLK	DCLK period	TOSC	-	156	-	ns	
	Frequency	FOSC	-	6.4	-	MHz	
RGB DATA	Data setup time	TSU	12	-	-	ns	
	Data hold time	THD	12	-	-	ns	
Hsync	Hsync period	TH	-	408	-	TOSC	
	Hsync pulse width	THS	5	30	-	TOSC	
	Display Period	THDP		320		TOSC	
	Back-Porch	THB		38		TOSC	
	Front-Porch	THF		20		TOSC	
	Hsync setup time	THts	12	-	-	ns	
	Hsync Hold time	THth	12	-	-	ns	
Vsync	Vsync period	TV	-	262	-	TH	
	Vsync pulse width	TVS	-	3	-	TH	
	Back-Porch	TVB		16		TH	
	Display Period	TVD		240		TH	
	Front Porch	TVF		3		TH	
	Vsync setup time	TVts	12	-	-	ns	
	Vsync Hold time	TVth	12	-	-	ns	
DEN	Vsync-DEN time	TVSE	-	19	-	TH	
	Hsync-DEN time	THE	-	68	-	TOSC	
	DEN plus width	TEP	-	320	-	TOSC	

Note: If DEN is fixed to low, the SYNC mode is used. Otherwise DE mode is used. When SYNC mode is used, 1st data start from 68th CLK after H-sync falling

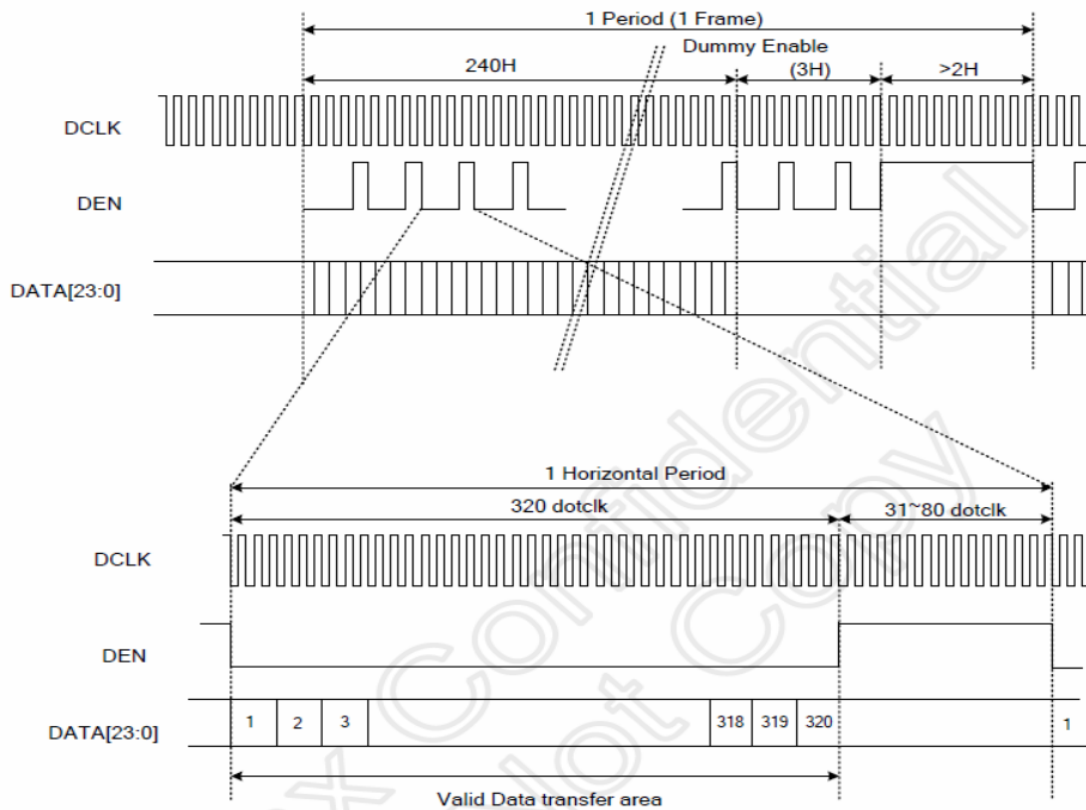



6.4 Timing Diagram of Interface Signal

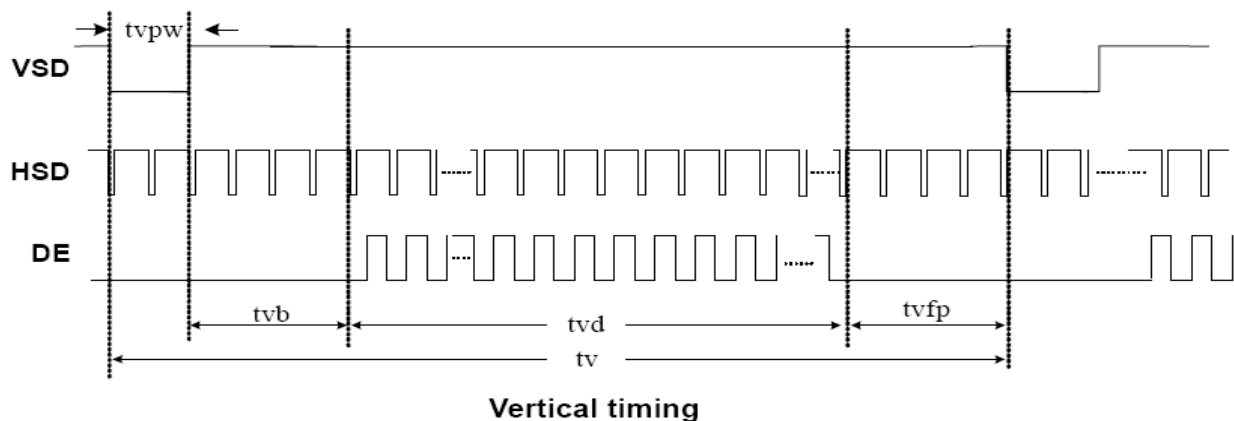
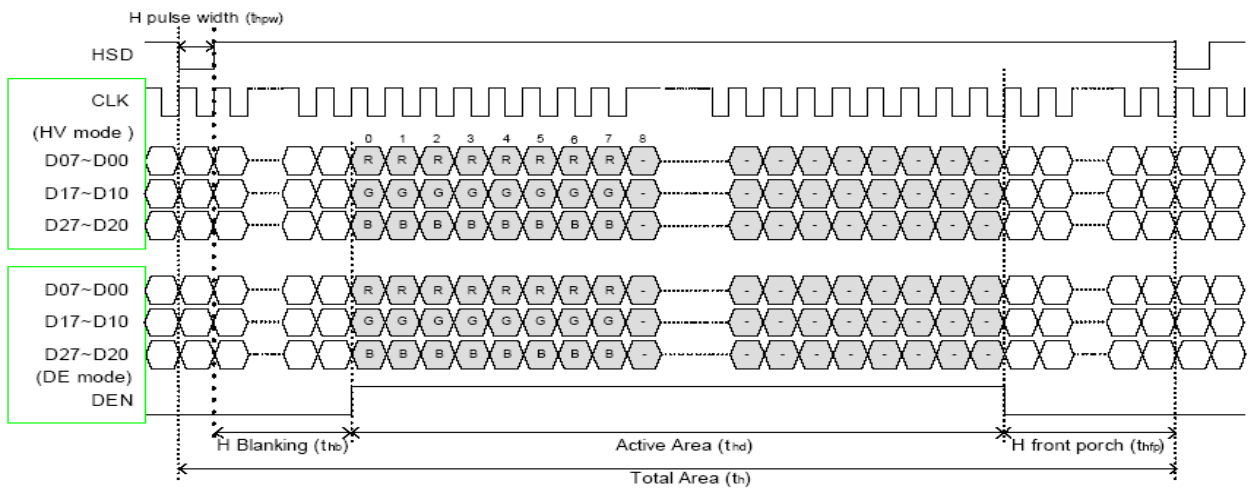
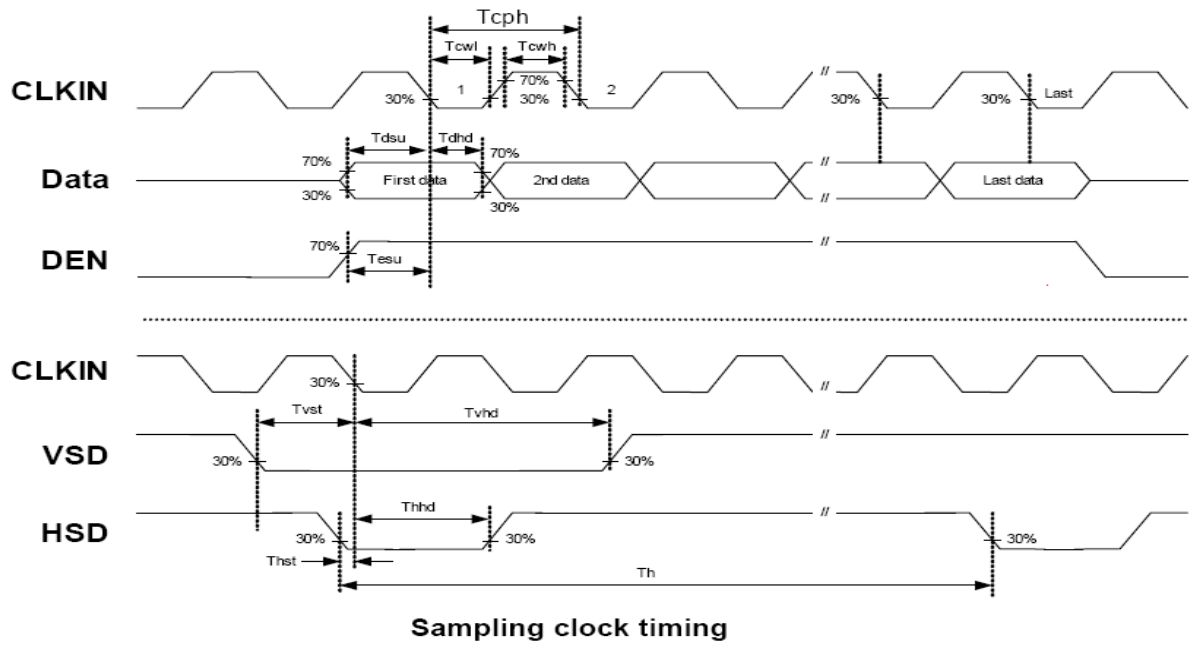



6.5 Power Sequence

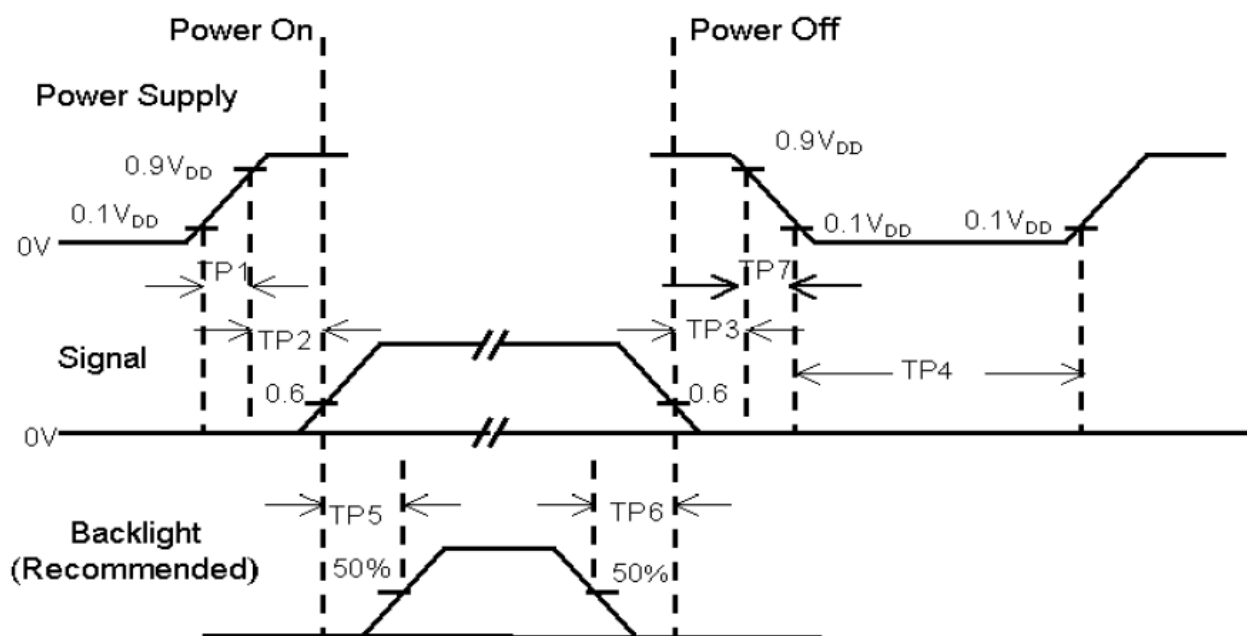

Item	Min.	Typ.	Max.	Unit	Remark
TP1	0.5	--	10	msec	
TP2	0	--	50	msec	
TP3	0	--	50	msec	
TP4	1000	--	--	msec	
TP5	200	--	--	msec	
TP6	200	--	--	msec	
TP7	0.5	--	10	msec	

Note : (1) The supply voltage of the external system for the module input should be the same as the definition of V_{DD} .

(2) Apply the lamp voltage within the LCD operation range. When the back-light turns on before the LCD operation or the LCD turns off before the back-light turns off, the display may momentarily become white.

(3) In case of V_{DD} = off level, please keep the level of input signal on the low or keep a high impedance.

(4) TP4 should be measured after the module has been fully discharged between power off and on period.

(5) Interface signal shall not be kept at high impedance when the power is on.



7.0 Reliability test items

NO.	Item	Conditions	Remark
1	High Temperature Storage	Ta=+80°C,240hrs	Inspection after 2~4 hours storage at room temperature, the sample shall be free from defects 1. Air bubble in the LCD 2. Sealleak 3. non-display 4. missing segments 5. glass crack 6. current idd is twice higher than initial value.
2	Low Temperature Storage	Ta=-30°C,240hrs	
3	High Temperature Operation	Ta=+70°C,240hrs	
4	Low Temperature Operation	Ta=-20°C,240hrs	
5	High Temperature and High Humidity(Operation)	Ta=+60°C, 90%RH, 240hrs	
6	Thermal cycling Test (non operation)	-20°C(30min)→+70°C(30min),100cycles	
7	Electrostatic discharge	200V 200pf(0ohm) 1time/each terminal	
8	Vibration	1. Random: 1.04 Grms,5~500HZ, X/Y/Z,30min/each direction 2. Sine: Freq. Range:8~33.3hz Stoke:1.3mm Sweep:2.9G,33.3~400HZ X/Z:2hr,Y:4hr,cyc:15min	
9	Shock	100G,6ms,±X, ±Y, ±Z 3 times for each direction	
10	Vibration(with carton)	Random:0.015G ^ 2/HZ, 5~200HZ -6dB/octave,200~400HZ XYZ each dirction:2hr	
11	Drop (with carton)	Height:60cm 1corner,3edges,6surfaces	

Note:

1. There is no display function NG issue occurred, all the cosmetic specification is judged before the reliability stress.

2. the test samples should be applied to only one test item

3. for damp proof test, Pure water(resistance>10M ohm)should be used

4. in case of malfunction defect caused by ESD damage, if it would be recovered to normal state after resetting, it would be judged as a good part

5. Failure Judgment Criterion: Basic Specification, Electrical Characteristic, Mechanical Charateristic, Optical Characteristic



8.0 OUTLINE DIMENSION

Outline Dimension:

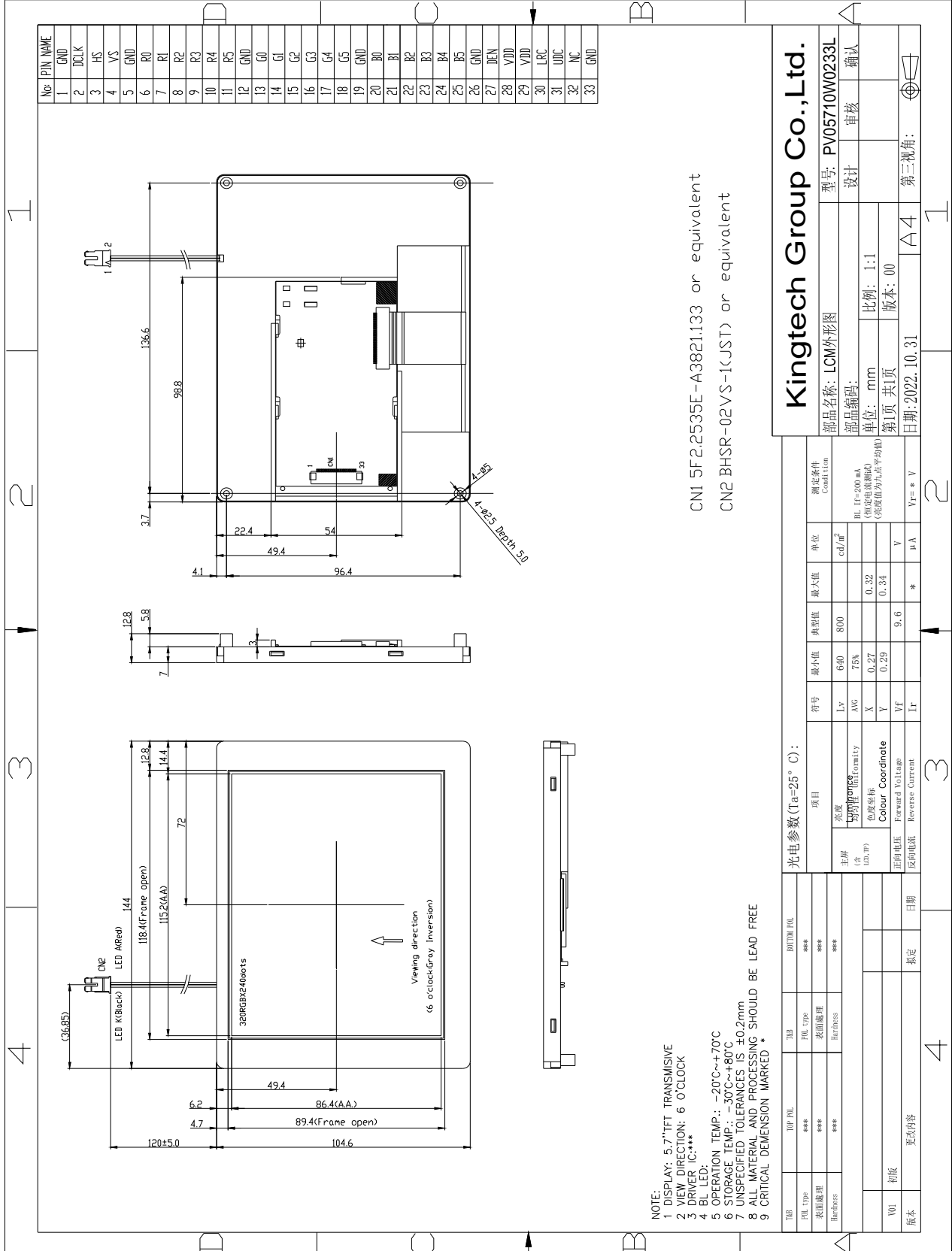



9.0 GENERAL PRECAUTION

9.1 Use Restriction

This product is not authorized for use in life supporting systems, aircraft navigation control systems, military systems and any other application where performance failure could be life threatening or otherwise catastrophic.

9.2 Disassembling or Modification

Do not disassemble or modify the module. It may damage sensitive parts inside LCD module, and may cause scratches or dust on the display. Kingtech does not warrant the module, if customers disassemble or modify the module.

9.3 Breakage of LCD Panel

9.3.1. If LCD panel is broken and liquid crystal spills out, do not ingest or inhale liquid crystal, and do not contact liquid crystal with skin.

9.3.2. If liquid crystal contacts mouth or eyes, rinse out with water immediately.

9.3.3. If liquid crystal contacts skin or cloths, wash it off immediately with alcohol and rinse thoroughly with water.

9.3.4. Handle carefully with chips of glass that may cause injury, when the glass is broken.

9.4 Electric Shock

9.4.1. Disconnect power supply before handling LCD module.

9.4.2. Do not pull or fold the LED cable.

9.4.3. Do not touch the parts inside LCD modules and the fluorescent LED's connector or cables in order to prevent electric shock.

9.5 Absolute Maximum Ratings and Power Protection Circuit

9.5.1. Do not exceed the absolute maximum rating values, such as the supply voltage variation, input voltage variation, variation in parts' parameters, environmental

temperature, etc., otherwise LCD module may be damaged. 9.5.2. Please do not leave LCD module in the environment of high humidity and high temperature for a long time. 11.5.3.

It's recommended to employ protection circuit for power supply.

9.6 Operation

9.6.1 Do not touch, push or rub the polarizer with anything harder than HB pencil lead.

9.6.2 Use fingerstalls of soft gloves in order to keep clean display quality, when persons handle the LCD module for incoming inspection or assembly.



9.6.3 When the surface is dusty, please wipe gently with absorbent cotton or other soft material.

9.6.4 Wipe off saliva or water drops as soon as possible. If saliva or water drops contact with polarizer for a long time, they may causes deformation or color fading.

9.6.5 When cleaning the adhesives, please use absorbent cotton wetted with a little petroleum benzine or other adequate solvent.

9.7 Mechanism

Please mount LCD module by using mouting holes arranged in four corners tightly.

9.8 Static Electricity

9.8.1 Protection film must remove very slowly from the surface of LCD module to prevent from electrostatic occurrence.

9.8.2. Because LCD module use CMOS-IC on circuit board and TFT-LCD panel, it is very weak to electrostatic discharge. Please be careful with electrostatic discharge. Persons who handle the module should be grounded through adequate methods.

9.9 Strong Light Exposure

The module shall not be exposed under strong light such as direct sunlight. Otherwise, display characteristics may be changed.

9.10 Disposal

When disposing LCD module, obey the local environmental regulations.

10. Package Specification

10.1 Packing format



(1) package quantity in one carton :60PCS .

(2) Carton size:43mmX37mmX18mm.



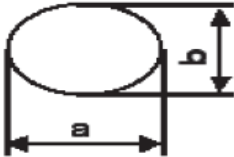
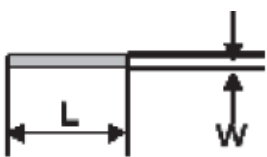
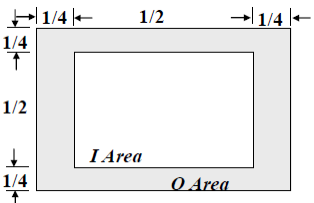

11. Visuals Specification: 1) Note

General	<p>1. Customer identified anomalies not defined within this inspection standard shall be reviewed by Kingtech, and an additional standard shall be determined by mutual consent.</p> <p>2. This inspection standard about the image quality shall be applied to any defect within the effective viewing area and shall not be applicable to outside of the area.</p> <p>3. Inspection conditions</p> <p>Luminance : 500 Lux min.</p> <p>Inspection distance : 300 mm.</p> <p>Temperature : 25±5°C</p> <p>Direction : Directly above</p>		
Definition of inspection item	Dot defect	Bright dot defect	<p>The dot is constantly “on” when power applied to the LCD, even when all “Black” data sent to the screen. Inspection tool: 5% Transparency neutral density filter. Count dot: If the dot is visible through the filter. Don’t count dot: If the dot is not visible through the filter.</p>  <p style="text-align: right;">■ dot defect</p>
		Black dot defect	<p>The dot is constantly “off” when power applied to the LCD, even when all “White” data sent to the screen.</p>
		Adjacent dot	<p>Adjacent dot defect is defined as two or more bright dot defects or black dot defects.</p>  <p style="text-align: right;">■ dot defect</p>
External inspection	Bubble ,scratch(foreign Particle polarizer, Cell, Backlight)		Visible operating (all pixels “Black” or “White”) and non operating.
	Appearance inspection	Does not satisfy the value at the spec.	
Others	LED wires	Damaged to the LED wires, connector, pin, functional failure or appearance failure.	
Definition of Size	<p>Definition of circle :  $d = (a + b) / 2$</p> <p>definition of linear size </p> <p>definition Area I/O </p>		



2) Standard

Classification		Inspection item		Judgment Standard		
Defect (in LCD glass)	Dot defect	Area		I	O	
		Bright dots(Note: Visible under:ND5%) 1:D≤0.15mm:No count); D>0.15mm acceptable: 0		N≤2		
		Dark dots (0.15mm<D≤0.3mm), D>0.3mm Not allowable		N≤3		
		Bright dot-2Adjacent		N≤0		
		Dark dot-2Adjacent		N≤0		
		Dark or bright dots-3 and more adjacent(note6)		N≤0		
		Total bright and dark dots		N≤5		
		Minimum distance between bright dots		5mm		
		Minimum distance between dark dots		5mm		
		Minimum distance between bright and bright dots		5mm		
	Other	White dot ,dark dot (circle)	Size (mm)		Acceptable number	
			d≤0.2		Neglected	
			0.2mm<D≤0.3mm		N≤4	
			0.3mm<D≤0.4mm		N≤2	
D>0.4mm			Not allowable			
Visual defect	Foreign partial	Circular foreign material: dark/bright sport		Visible under:ND5% 1:D≤0.15mm:No count 2:0.15mm<D≤0.3mm,N≤4 3:D>0.3mm:Not allowable		
		Linear foreign material: bright or dark line		Invisible under ND5% 0.1mm<W≤0.3mm, 0.3mm<L≤1.5mm,N≤4 Visible under ND5% 0.05mm≤w≤0.1mm, 0.3mm≤L≤0.7mm,N≤4		
	Polarizer	Linear scratch		1:BM:No Count 2:Pixel area 0.05mm≤w≤0.2mm, 1.0mm≤L≤5.0mm,N≤4		
		Bubble peeling		1:BM:No Count 2:Pixel area 0.15mm≤D<0.3mm,N≤4		
	Mura & leak				ND5%	