



# PRODUCT SPECIFICATIONS

For Customer: \_\_\_\_\_

: APPROVAL FOR SPECIFICATION

Customer Model No. \_\_\_\_\_

: APPROVAL FOR SAMPLE

Module No.: PV05706D0160G

Date : 2022-08-15

**Table of Contents**

No.	Item	Page
1	Cover Sheet(Table of Contents)	P1
2	Revision Record	P2
3	General Specifications	P3
4	Outline Drawing	P4
5	Absolute Maximum Ratings	P5
6	Electrical Specifications	P6-P10
7	Optical Characteristics	P11-P14
8	Reliability Test Items and Criteria	P15
9	Precautions for Use of LCD Modules	P16-P17

**For Customer's Acceptance:**

Approved By	Comment

PREPARED	CHECKED	VERIFIED BY QA DEPT	VERIFIED BY R&D DEPT
KIIN			





### 3. General Specifications

*PV05706D0160G is a TFT-LCD module. It is composed of a TFT-LCD panel, driver IC , FPC, a backlight unit. The 5.7 '' display area contains 640 x 480pixels and can display up to 16.7M colors. This product accords with RoHS environmental criterion.*

Item	Contents	Unit	Note
LCD Type	TFT	-	
Display color	16.7M		
Viewing Direction	ALL	O'Clock	
Operating temperature	-20~+70	°C	
Storage temperature	-30~+80	°C	
Module size	Refer to outline drawing	mm	
Active Area(W×H)	115.20X86.40	mm	
Number of Dots	640×480	dots	
TFT Driver IC	JD9168S	-	
Power Supply Voltage	3.3	V	
Outline Dimensions	Refer to outline drawing	-	
Backlight	3X7-LEDs	pcs	
Weight	TBD	g	

*Note 1: Color tune is slightly changed by temperature and driving voltage.*

*Note 2: Without FPC and Solder.*



# 4.Outline.Drawing

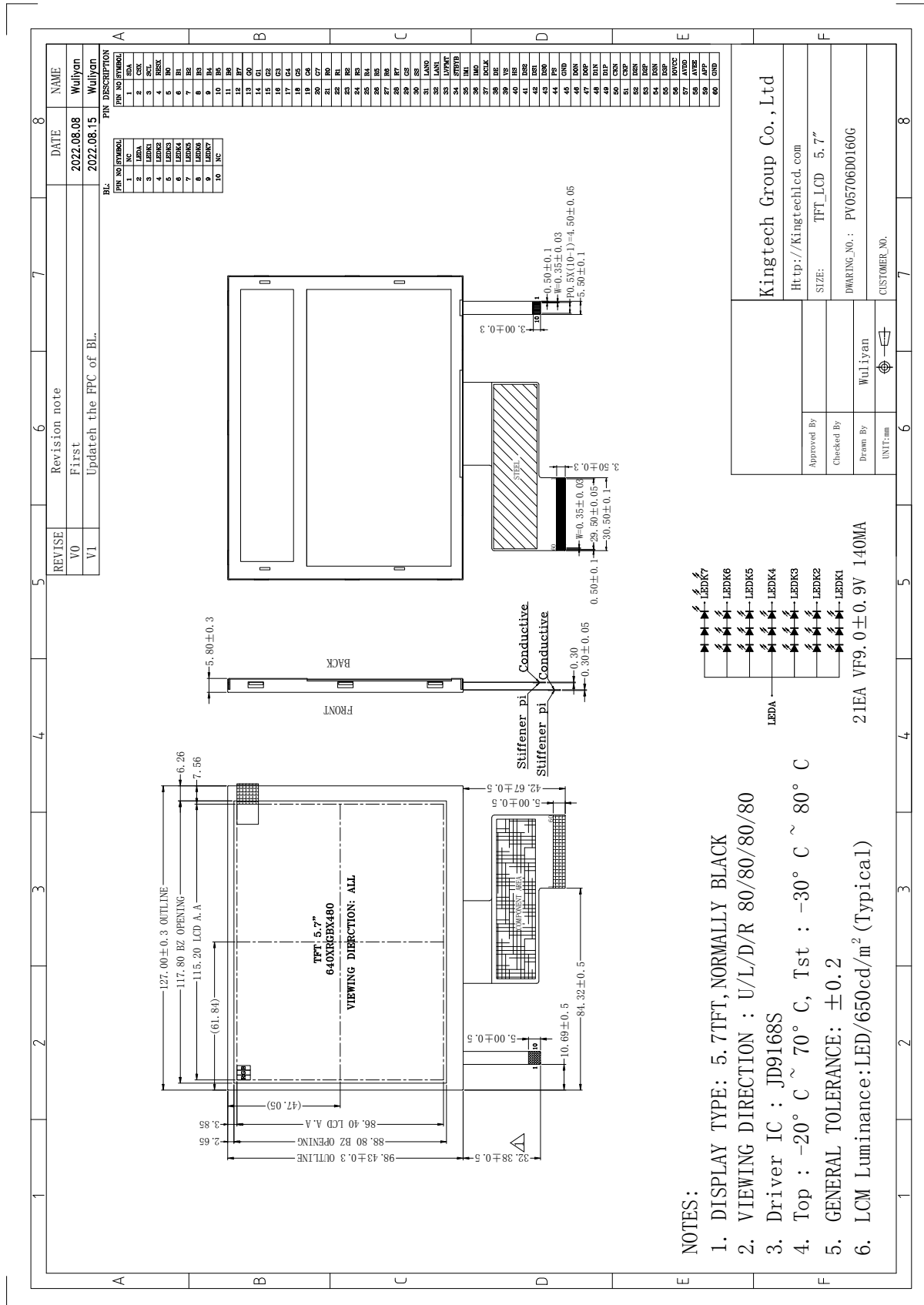

REVISE	Revision note	DATE	NAME
V0	First	2022.08.08	Wuliyan
V1	Update the FPC of BL.	2022.08.15	Wuliyan

PIN NO SYMBOL		PIN DESCRIPTION	
1	SDA	11	B+
2	SCL	12	B7
3	LEDA	13	OD
4	LEDA	14	OD
5	LEDA	15	OD
6	LEDA	16	OD
7	LEDA	17	OD
8	LEDA	18	OD
9	LEDA	19	OD
10	LEDA	20	OD
11	NC	21	B+
12	NC	22	B7
13	NC	23	B+
14	NC	24	B+
15	NC	25	B+
16	NC	26	B+
17	NC	27	B+
18	NC	28	B7
19	NC	29	B7
20	NC	30	B7
21	NC	31	LAN+
22	NC	32	LAN-
23	NC	33	LVTT+
24	NC	34	LVTT-
25	NC	35	AVTT+
26	NC	36	AVTT-
27	NC	37	DCX
28	NC	38	DB
29	NC	39	DB
30	NC	40	DB
31	NC	41	DB
32	NC	42	DB
33	NC	43	DB
34	NC	44	DB
35	NC	45	DB
36	NC	46	DB
37	NC	47	DB
38	NC	48	DB
39	NC	49	DB
40	NC	50	DB
41	NC	51	DB
42	NC	52	DB
43	NC	53	DB
44	NC	54	DB
45	NC	55	DB
46	NC	56	DB
47	NC	57	DB
48	NC	58	DB
49	NC	59	DB
50	NC	60	DB

Kingtech Group Co., Ltd	
Http://Kingtechlcd.com	
Approved By	
Checked By	
Drawn By	Wuliyan
UNIT:mm	
SIZE: TFT_LCD 5.7"	
DRAWING_NO.: PV05706D0160G	
CUSTOMER_NO.	

- NOTES:
1. DISPLAY TYPE: 5.7TFT, NORMALLY BLACK
  2. VIEWING DIRECTION : U/L/D/R 80/80/80/80
  3. Driver IC : JD9168S
  4. Top : -20° C ~ 70° C, Tst : -30° C ~ 80° C
  5. GENERAL TOLERANCE: ±0.2
  6. LCM Luminance: LED/650cd/m<sup>2</sup> (Typical)



**5. Absolute Maximum Ratings(Ta=25 °C)**

**5.1 Electrical Absolute Maximum Ratings.(Vss=0V ,Ta=25 °C)**

Item	Symbol	Min.	Max.	Unit	Note
Power Supply Voltage	IOVCC	-0.3	3.6	V	1, 2
Analog power	V <sub>AVDD</sub>	-0.3	6.6	V	
Analog power	V <sub>AVEE</sub>	-0.3	-6.6	V	

Notes:

1. If the module is above these absolute maximum ratings. It may become permanently damaged. Using the module within the following electrical characteristic conditions are also exceeded, the module will malfunction and cause poor reliability.
2. VCC >V<sub>SS</sub> must be maintained.
3. Please be sure users are grounded when handing LCD Module.

**5.2 Environmental Absolute Maximum Ratings.**

Item	Storage		Operating		Note
	MIN.	MAX.	MIN.	MAX.	
Ambient Temperature	-30°C	80°C	-20°C	70°C	1,2
Humidity	-	-	-	-	3

1. The response time will become lower when operated at low temperature.
2. Background color changes slightly depending on ambient temperature.  
The phenomenon is reversible.
3. Ta<=40 °C:85%RH MAX.  
Ta>=40 °C:Absolute humidity must be lower than the humidity of 85%RH at 40 °C.



## 6. Electrical Specifications and Instruction Code

### 6.1 Electrical characteristics(V<sub>SS</sub>=0V ,T<sub>a</sub>=25°C)

Parameter	Symbol	Condition	Min	Typ	Max	Unit	Note
Power supply	IOVCC	T <sub>a</sub> =25°C	2.5	3.3	3.6	V	
Input voltage	'H'	V <sub>IH</sub>	IOVCC=3.3V	0.7V*IOVCC	-	IOVCC	V
	'L'	V <sub>IL</sub>	IOVCC=3.3V	0	-	0.3V*IOVCC	V
Power supply	AVDD	T <sub>a</sub> =25°C	4.5	5.79	6.0	V	
Power supply	AVEE	T <sub>a</sub> =25°C	2.5	-5.77	-6.0	V	
Power supply	I <sub>IOVCC</sub>	T <sub>a</sub> =25°C	-	5.52	-	mA	
Power supply	I <sub>AVDD</sub>	T <sub>a</sub> =25°C	-	8.16	-	mA	
Power supply	I <sub>AVEE</sub>	T <sub>a</sub> =25°C	-	7.89	-	mA	

### 6.2 LED backlight specification(V<sub>SS</sub>=0V ,T<sub>a</sub>=25°C)

Item	Symbol	Condition	Min	Typ	Max	Unit	Note
Supply voltage	V <sub>f</sub>	I <sub>f</sub> =140mA	-	9.0	-	V	
Uniformity	Δ Bp	I <sub>f</sub> =140mA	80	-	-	%	
Life time	-	I <sub>f</sub> =140mA	20K	-	-	hour	1

Note:

1 : The "LED Life time" is defined as the module brightness decrease to 50% original brightness at T=25°C and I<sub>f</sub>=220mA. The LED Life time could be decreased if operating I<sub>f</sub> is larger than 220mA.

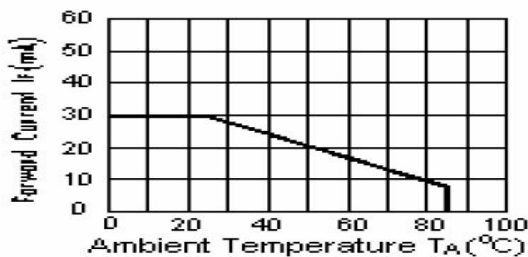



## ILED VS TEMP

**6.3 Interface signals**

Pin No.	Symbol	I/O	Function
1	SDA	I	Serial data input / output pin in SPI interface operation.
2	CSX	I	Chip select pin. 0: Chip can be accessed; 1: Chip cannot be accessed.
3	SCL	I	Serial clock input in SPI interface .
4	RESET	I	Global reset signal input pin.
5-12	B0-B7	I	Blue data bus.
13-20	G0-G7	I	Green data bus.
21-28	R0-R7	I	Red data bus.
29	GS	I	Gate driver scan direction on panel module
30	SS	I	Source driver scan direction on panel module.
31	LAN0	I	Select the lane mode as listed below.
32	LAN1	I	Select the lane mode as listed below.
33	LVMFT	I	Data format select for LVDS mode.
34	STBYB	I	Standby mode control pin.
35-36	IM1-IM0	I	RGB IF data format (RGB565 / RGB666 / RGB888) is selected by DCS command (0x3A).
37	DCLK	I	Pixel clock input in RGB interface.
38	DE	I	Data enable input in RGB interface.
39	VS	I	Vertical sync input in RGB interface.
40	HS	I	Horizontal sync input in RGB interface.
41	DS2	P	Ground.
42	DS1	P	Ground.
43	DS0	P	Ground.
44	PS	I	A power supply for the I/O circuit.
45	GND	P	Ground.
46	D0N	I	-LVDS differential data input (Data lane 0).
47	D0P	I	+LVDS differential data input (Data lane 0).
48	D1N	I	-LVDS differential data input (Data lane 1).
49	D1P	I	+LVDS differential data input (Data lane 1).
50	CKN	I	-LVDS differential clock signal data input.
51	CKP	I	+LVDS differential clock signal data input.
52	D2N	I	-LVDS differential data input (Data lane 2).
53	D2P	I	+LVDS differential data input (Data lane 2).
54	D3N	I	-LVDS differential data input (Data lane 3).
55	D3P	P	+LVDS differential data input (Data lane 3).
56	IOVCC	I	A power supply for the I/O circuit.



57	AVDD	I	Input positive power from system/ external power IC.
58	AVEE	I	Input negative power from system/ external power IC.
59	VPP	I	External High voltage pin is used in OTP program mode, the power is operate at 7.5V.
60	GND	P	Ground.

## 6.4 Timing Characteristics

### 6.4.1 SPI mode data input format

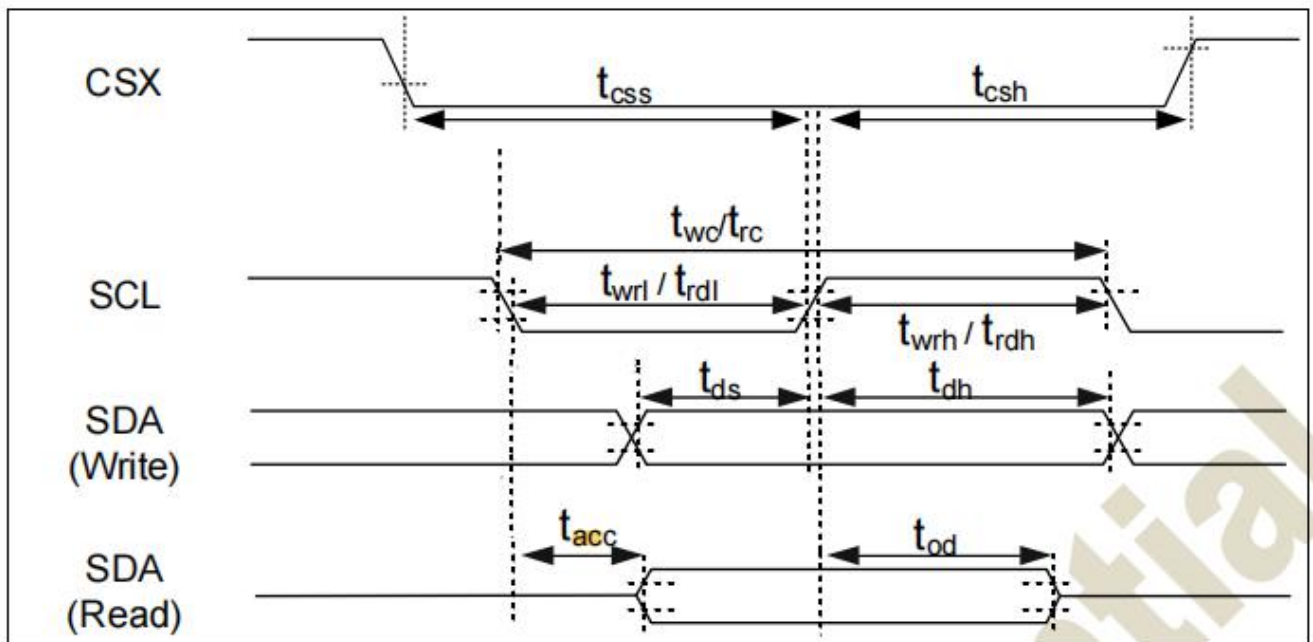

SPI interface AC characteristics

( $T_A=25^{\circ}C$ ,  $IOVCC=3.3V$ ,  $VCI=3.3V$ )

Signal	Symbol	Parameter	Min.	Max.	Unit	Description
CSX	$t_{css}$	Chip select setup time (Write)	40	-	ns	-
	$t_{csh}$	Chip select setup time (Read)	40	-		
SCL (Write)	$t_{wc}$	Write cycle	100	-	ns	-
	$t_{wrh}$	Control pulse "H" duration	40	-		
	$t_{wrl}$	Control pulse "L" duration	40	-		
SCL (Read)	$t_{rc}$	Read cycle	150	-	ns	-
	$t_{rdh}$	Control pulse "H" duration	60	-		
	$t_{rdl}$	Control pulse "L" duration	60	-		
SDA (Write)	$t_{ds}$	Data setup time	30	-	ns	Note <sup>(1)</sup>
	$t_{dt}$	Data hold time	30	-		
SDA (Read)	$t_{acc}$	Read access time	-	35	ns	
	$t_{od}$	Output disable time	10	50		

SPI interface AC characteristics



**6.4.2 LVDS mode data input format**

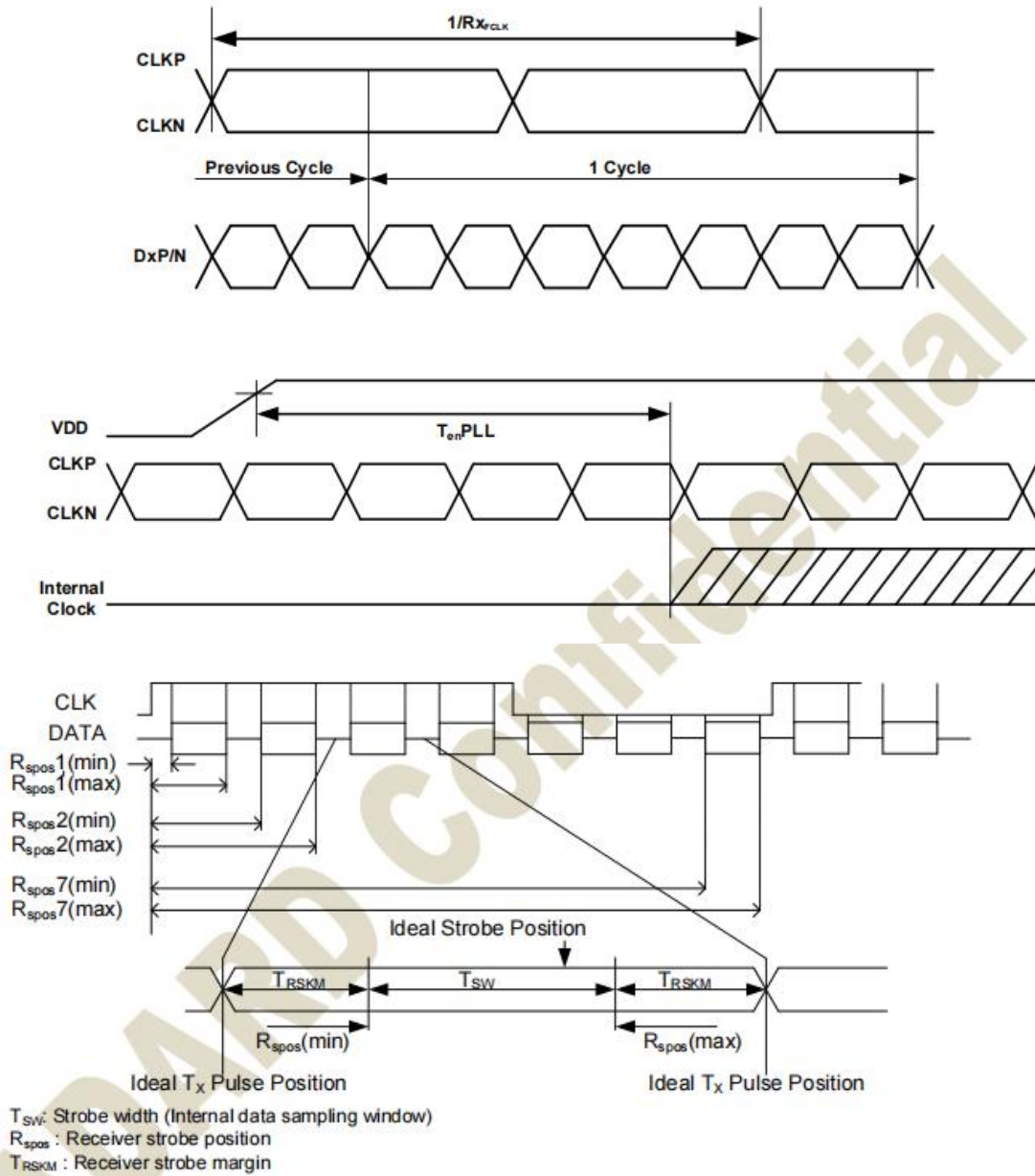

**LVDS AC characteristics**



**6.4.2 LVDS mode AC electrical Characteristics**

Signal	Symbol	Min.	Typ	Max.	Unit	Description
Clock frequency	R <sub>X</sub> FCLK	30	-	TBD	MHz	Refer to input timing table for each display resolution
Input data skew margin	T <sub>RSKM</sub>	500	-	-	ps	VID  = 200mV R <sub>x</sub> VCM = 1.2V R <sub>x</sub> FCLK = 81MHz
Clock high time	T <sub>LVCH</sub>	-	4/(7x R <sub>X</sub> FCLK)	-	ns	-
Clock low time	T <sub>LVCL</sub>	-	3/(7xR <sub>X</sub> FCLK)	-	ns	-
PLL wake-up time	T <sub>enPLL</sub>	-	-	150	us	-

LVDS AC characteristics



## 7. Optical Characteristics

Item	Symbol	Condition	Min.	Typ.	Max.	Unit	Note	
Brightness	Bp	$\theta=0^\circ$	-	650	-	Cd/m <sup>2</sup>	1	
Uniformity	$\Delta$ Bp	$\Phi=0^\circ$	80	-	-	%	1,2	
Viewing Angle	3:00	Cr $\geq$ 10	75	80	-	Deg	3	
	6:00		75	80	-			
	9:00		75	80	-			
	12:00		75	80	-			
Contrast Ratio	Cr	$\theta=0^\circ$ $\Phi=0^\circ$	1000	1200	-	-	4	
Response Time	T <sub>r</sub> +T <sub>f</sub>		-	30	35	ms	5	
Color of CIE Coordinate	W	x	$\theta=0^\circ$	0.262	0.292	0.322	-	1,6
		y	$\Phi=0^\circ$	0.307	0.337	0.367	-	
	R	x	$\theta=0^\circ$	0.620	0.650	0.680	-	
		y	$\Phi=0^\circ$	0.292	0.322	0.352	-	
	G	x	$\theta=0^\circ$	0.250	0.280	0.310	-	
		y	$\Phi=0^\circ$	0.534	0.564	0.594	-	
	B	x	$\theta=0^\circ$	0.105	0.292	0.322	-	
		y	$\Phi=0^\circ$	0.307	0.337	0.364	-	
transmittance	TR	-	4.0	4.7	-	%		
Color Gamut	CG	-	55	60	-	%		

Note: The parameter is slightly changed by temperature, driving voltage and materiel

Note 1: The data are measured after LEDs are turned on for 5 minutes. LCM displays full white. The brightness is the average value of 9 measured spots. Measurement equipment PR-705 (Φ8mm)

Measuring condition:

- Measuring surroundings: Dark room.
- Measuring temperature: T<sub>a</sub>=25 °C.
- Adjust operating voltage to get optimum contrast at the center of the display.

Measured value at the center point of LCD panel after more than 5 minutes while backlight



turning on.

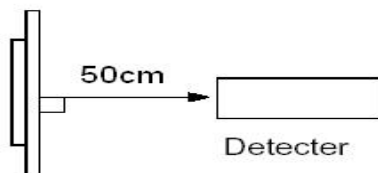

Note 2: The luminance uniformity is calculated by using following formula.

$$\Delta Bp = Bp (\text{Min.}) / Bp (\text{Max.}) \times 100 (\%)$$

$Bp (\text{Max.})$  = Maximum brightness in 9 measured spots

$Bp (\text{Min.})$  = Minimum brightness in 9 measured spots.

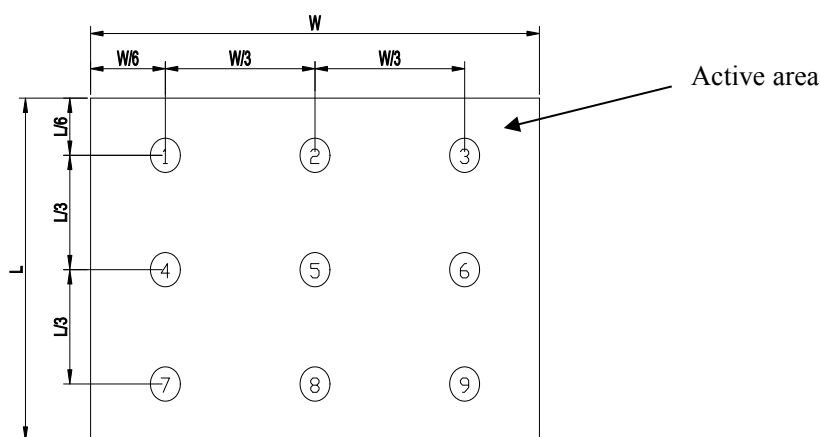

Note 3: The definition of viewing angle:

Refer to the graph below marked by  $\vartheta$  and  $\Phi$

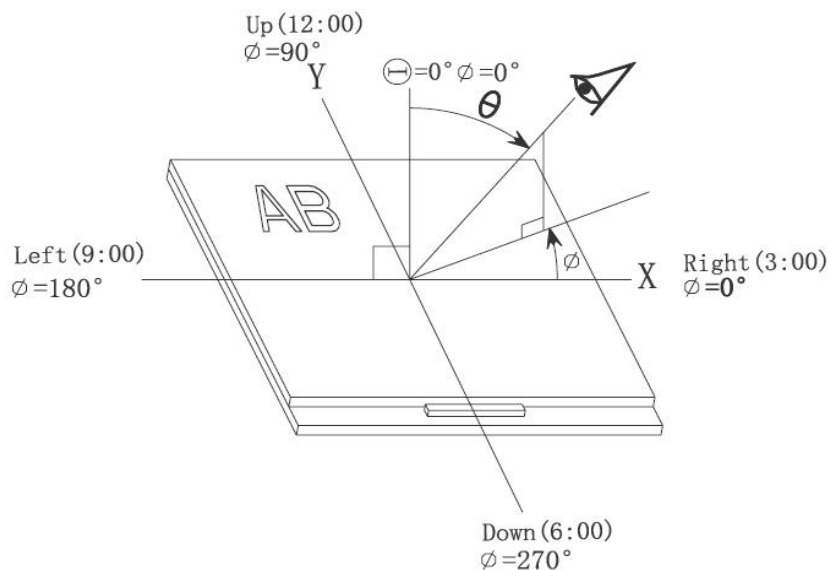

Note 4: Definition of contrast ratio.( Test LCD using DMS501)

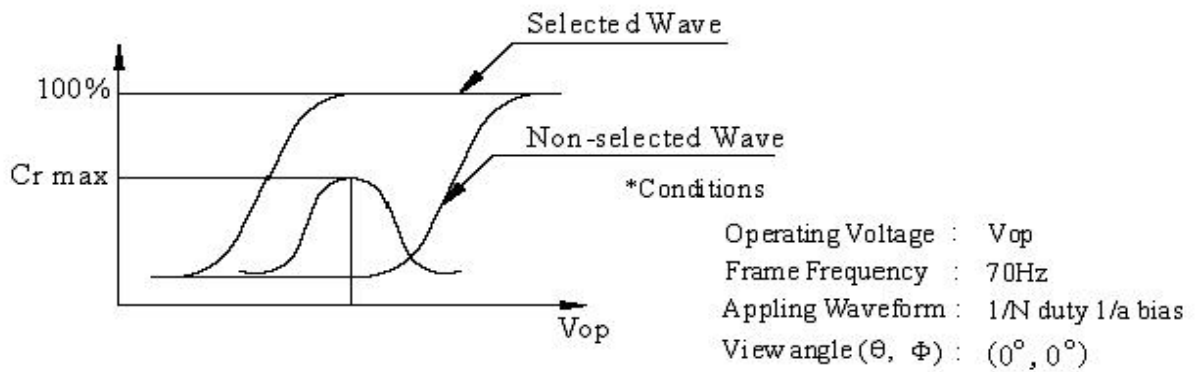

$$\text{Contrast ratio}(Cr) = \frac{\text{Brightness of selected dots}}{\text{Brightness of non-selected dots}}$$

Note 5: Definition of Response time. (Test LCD using DMS501):

The output signals of photo detector are measured when the input signals are changed from "black" to "white"(falling time) and from "white" to "black"(rising time), respectively. The response time is defined as the time interval between the 10% and 90% of amplitudes. Refer to figure as below.

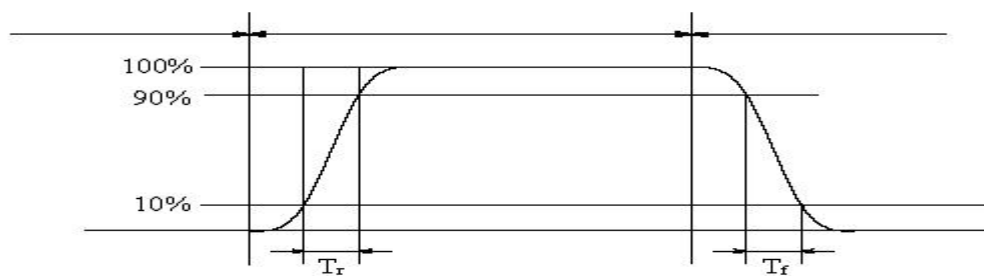

The definition of response time

Note 6: Definition of Color of CIE Coordinate and NTSC Ratio.

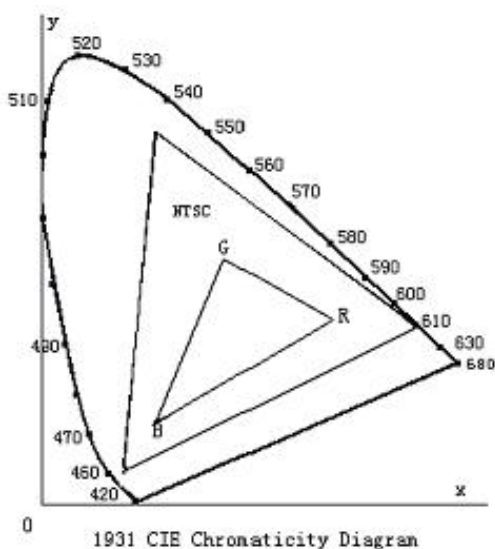

Color gamut:

$$S = \frac{\text{area of RGB triangle}}{\text{area of NTSC triangle}} \times 100\%$$

Note 7: Definition of cross talk.

$$\text{Cross talk ratio}(\%) = \frac{|\text{pattern A Brightness} - \text{pattern B Brightness}|}{\text{pattern A Brightness}} \times 100$$

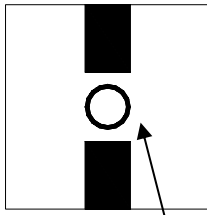

Pattern A

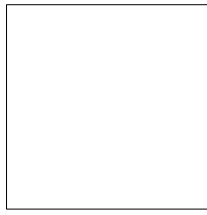

Pattern B

Measurement point(center)

Electric volume value=3F+/-3Hex



## 8. Reliability Test Items and Criteria

Test Item	Test condition	Remark
High Temperature Storage	Ta =80°C 96hrs	Note1,Note3,4
Low Temperature Storage	Ta = -30°C 96hrs	Note1,Note3,4
High Temperature Operation	Ts = 70°C 96hrs	Note2,Note3,4
Low Temperature Operation	Ta = -20°C 96hrs	Note1,Note3,4
Operation at High Temperature/Humidity	+60°C, 90%RH 96hrs	Note3,4
Thermal Shock	-20°C/30 min ~ +60°C/30 min for a total 100 cycles, Start with cold temperature and end with high temperature.	Note3,4
Vibration Test	Frequency range:10~55Hz Stroke:1.5mm Sweep:10Hz~55Hz~10Hz 2 hours for each direction of X. Y. Z. (6 hours for total)	
Mechanical Shock	100G 6ms,±X, ±Y, ±Z 3 times for each direction	
Package Vibration Test	Random Vibration : 0.015G*G/Hz from 5-200HZ, -6dB/Octave from 200-500HZ 2 hours for each direction of X. Y. Z. (6 hours for total)	
Package Drop Test	Height:60cm 1 corner, 3 edges, 6 surfaces	
Electro Static Discharge	±2KV, Human Body Mode, 100pF/1500Ω	

Note 1: Ta is the ambient temperature of samples.

Note 2: Ts is the temperature of panel's surface.

Note 3: In the standard condition, there shall be no practical problem that may affect the display function. After the reliability test, the product only guarantees operation, but don't guarantee all of the cosmetic specification.

Note 4: Before cosmetic and function test, the product must have enough recovery time,at least 2 hours at room temperature



## 9. Precautions for Use of LCD Modules

### 9.1 Handling Precautions

9.1.1 The display panel is made of glass. Do not subject it to a mechanical shock by dropping it from a high place, etc.

9.1.2 If the display panel is damaged and the liquid crystal substance inside it leaks out, be sure not to get any in your mouth, if the substance comes into contact with your skin or clothes, promptly wash it off using soap and water.

9.1.3 Do not apply excessive force to the display surface or the adjoining areas since this may cause the color tone to vary.

9.1.4 The polarizer covering the display surface of the LCD module is soft and easily scratched. Handle this polarizer carefully.

9.1.5 If the display surface is contaminated, breathe on the surface and gently wipe it with a soft dry cloth. If still not completely clear, moisten cloth with one of the following solvents:

- Isopropyl alcohol
- Ethyl alcohol

Solvents other than those mentioned above may damage the polarizer. Especially, do not use the following:

- Water
- Ketone
- Aromatic solvents

9.1.6 Do not attempt to disassemble the LCD Module.

9.1.7 If the logic circuit power is off, do not apply the input signals.

9.1.8 To prevent destruction of the elements by static electricity, be careful to maintain an optimum work environment.

a. Be sure to ground the body when handling the LCD Modules.

b. Tools required for assembly, such as soldering irons, must be properly ground.

c. To reduce the amount of static electricity generated, do not conduct assembly and other work under dry conditions.

d. The LCD Module is coated with a film to protect the display surface. Be care when peeling off this protective film since static electricity may be generated.



## **9.2 Storage precautions**

9.2.1 *When storing the LCD modules, avoid exposure to direct sunlight or to the light of fluorescent lamps.*

9.2.2 *The LCD modules should be stored under the storage temperature range. If the LCD modules will be stored for a long time, the recommend condition is:*

*Temperature :        0 °C ~ 40 °C*

*Relatively humidity: ≤80%*

9.2.3 *The LCD modules should be stored in the room without acid, alkali and harmful gas.*

**9.3 *The LCD modules should be no falling and violent shocking during transportation, and also should avoid excessive press, water, damp and sunshine.***

**END**