



PRODUCT 产品规格: 5.7 TFT

MODEL NO. 模组型号: PV05704Y0430E

CUSTOMER 客户: _____

SPECIFICATION

FOR

PV05704Y0430E 产品规格书

版本: **V 1.0**

customer Confirmation column 客户确认栏

Approved by 核准: _____ Dept. 部门: _____ Data 日期: _____

Please return one of the copies of the specification with your signature to us
请贵司在收到规格书的两周内, 将签好字的规格书原件或者复印件寄回. 如果没有返回,
within two weeks after you receive this document. If it is not returned, we will
我司将会认为贵司已经默认接受产品规格书中的全部资料和规范.
assume that you agree to the entire contents of this specification document.

Preliminary Specification 样品规格书

Final Specification 量产规格书

Design 制作: _____ Check 检查: _____ Approval 审核: _____



CONTENTS 内容

No. 编号	ITEM 项目	PAGE 页码
1.	GENERAL INFORMATION	4
2.	ABSOLUTE MAXIMUM RATINGS	5
3.	DIAGRAM FOR LCM	6
4.	I/O CONNECTION & BLOCK DIAGRAM	7~8
5.	ELECTRICAL CHARACTERISTICS	9~13
6.	ELECTRO-OPTICAL CHARACTERISTICS	14~16
7.	RELIABILITY TEST CONDITIONS	19
8.	PACKAGE DRAWING	18



1. GENERAL INFORMATION

1.1 features

- 1) Display Format: 5.7 HD+ Vertical Stripe (720*1440)
- 2) Interface : MIPI 4 lane
- 3) Driver IC : JD9365D
- 4) Touch IC : GT5688
- 5) Operation Temperature : -10~60°C
- 6) Storage Temperature : -20~70°C
- 7) Backlight Type: White LED
- 8) Display mode:, Normally Black
- 9) CTP cover lens: 康宁大猩猩
- 10) CTP surface hardness : ≥6H

1.2 mechanical specification

Item	Contents	Unit
LCD Type	LTPS TFT/TRANSMISSIVE	/
Panel Size	5.7	inch
Pixel arrangement	720*3 (RGB) *1440	Dots
Active Area	64.8 (H) *129.6 (V)	mm
Pixel pitch (W*H)	0.09 (V) *0.09 (V)	mm
Module area (W*H*T) (LCM+TP)	73.23 (H) *145.99 (V) *2.93 (T)	mm
Recommended Viewing Direction	ALL	0' clock



2. ABSOLUTE MAXIMUM RATINGS

(GND=AGND=0V)

Parameter of absolute maximum ratings 参数	Symbol 符号	Min 最小值	Max 最大值	Unit 单位
Power supply voltage1	IOVDD	-0.3	4.6	V
Power supply voltage2	VDD	-0.3	4.6	V
Backlight forward current	I _{LED}	-0.001	30	mA(For each led)
Reverse Voltage	V _R	-	5	V
Operating temperature	T _{op}	-10	60	°C
Storage temperature	T _{st}	-20	70	°C
Humidity	RH	-	90%(Max)/60°C	RH



3. DIAGRAM FOR LCM

基本规格:		5.7" HD- IPS TFT
DISPLAY TYPE:	NORMALLY BLACK	
TRANSMISSIVE		
RESOLUTION:	720 (RGB) *1440	
Driver IC:	JD93850	
Viewing Angle(D/L/R):	80/80/80/80 Typ	
LCM BRIGHTNESS:	450 cd/m2 Min 500 cd/m2 Typ	
Contrast:	1000:1 Typ	
NTSC:	80% Min	
Uniformity:		
Gamma:		
CROSS-TALK:		
BACKLIGHT:	14pcs, 7#海耳40um(20um/LED)	
Interface:	MIP VIDEO MODE	
OPERATING TEMP:	-10°C ~ 60°C	
STORAGE TEMP:	-20°C ~ 70°C	
电压:	VDD=1.8V (TYP) VDD=2.8V (TYP)	
平面度:	0.35MM MAX	
寄存器地址:		

产 品 规 格		
DISPLAY TYPE:	5.7" HD- IPS TFT	
TRANSMISSIVE		
RESOLUTION:	720 (RGB) *1440	
Driver IC:	JD93850	
Viewing Angle(D/L/R):	80/80/80/80 Typ	
LCM BRIGHTNESS:	450 cd/m2 Min 500 cd/m2 Typ	
Contrast:	1000:1 Typ	
NTSC:	80% Min	
Uniformity:		
Gamma:		
CROSS-TALK:		
BACKLIGHT:	14pcs, 7#海耳40um(20um/LED)	
Interface:	MIP VIDEO MODE	
OPERATING TEMP:	-10°C ~ 60°C	
STORAGE TEMP:	-20°C ~ 70°C	
电压:	VDD=1.8V (TYP) VDD=2.8V (TYP)	
平面度:	0.35MM MAX	
寄存器地址:		

NOTE:

- VIEWING DIRECTION: FULL view
- 本产品的尺寸要求
- GENERAL TOLERANCE: ±0.2 (*) Reference dimension
- *为重点尺寸
- 客户终端使用连接器型号: BR1P4-006101
- 产品要求SLEP可以硬件无供电
- 建议配合的PC开槽尺寸比LCD AA左右宽度尺寸单边大0.25
- FSD(垫脚): 接触/8N5, 空气/12KX

背光电路图
(CIRCUIT DIAGRAM)

尺寸规格:

720RGBX1440 Dots
VIEWING DIRECTION ALL
5.7" TFT

正偏电源线
背光电源线
背光控制线

VER.	SYMBOL	AMENDMENT	DATE	DESCRIPTION
01	△	更改PCB开槽位置	2018.02.27	WYJ
02	△	更改PCB开槽位置	2018.04.11	LL
03	△	标题上增加客户型号	2018.04.11	LL

DRAWN	ME. CHECKED	EE. CHECKED	APPROVED
DATE	DATE	DATE	DATE

产品PFC零件示意图

LCM PIN

No.	PIN NAME
1	GND
2	VDD-2.8V
3	VDD-2.8V
4	10VDD-1.8V
5	GND
6	LCM-ID
7	RESSET
8	GND
9	DSL-TE
10	GND
11	GND
12	LEB-12
13	LEB-11
14	LEB-A
15	GND
16	DSL-DSP
17	DSL-D2N
18	GND
19	DSL-D2P
20	DSL-D2N
21	GND
22	DSL-CLAP
23	DSL-CLAN
24	GND
25	DSL-D1P
26	DSL-D1N
27	GND
28	DSL-D0P
29	DSL-D0N
30	GND

DRIVING NO.

PV05704Y0430E

Kingtech Group Co., Ltd.



4. I/O CONNECTION & BLOCK DIAGRAM

4.1 I/O connection for LCM

Pin NO.	Symbol	I/O	Description
1	GND	P	Power Ground
2-3	VDD_2.8V	P	Power supply for analog circuits (2.8V)
4	IOVDD	P	Power supply for digital circuits and IO pads(1.8V)
5	GND	P	Power Ground
6	LCD_ID	O	ID Select
7	RESET	I	Chip reset signal
8	GND	P	Power Ground
9	DSI_TE	O	Dummy
10-11	GND	P	Power Ground
12	LED-K2	P	Power supply for LED cathode
13	LED-K1	P	Power supply for LED cathode
14	LED-A	P	Power supply for LED anode
15	GND	P	Power Ground
16	DSI-D3P	I	differential data signals for MIPI interface
17	DSI-D3N	I	differential data signals for MIPI interface
18	GND	P	Power Ground
19	DSI-D2P	I	differential data signals for MIPI interface
20	DSI-D2N	I	differential data signals for MIPI interface
21	GND	P	Power Ground
22	DSI-CLKP	I	differential data signals for MIPI interface
23	DSI-CLKN	I	differential data signals for MIPI interface
24	GND	P	Power Ground
25	DSI-D1P	I	differential data signals for MIPI interface
26	DSI-D1N	I	differential data signals for MIPI interface
27	GND	P	Power Ground
28	DSI-D0P	I	differential data signals for MIPI interface
29	DSI-D0N	I	differential data signals for MIPI interface
30	GND	P	Power Ground

I: Input; O: Output; P: Power

I: Input; O: Output; P: Power



4.3 block diagram

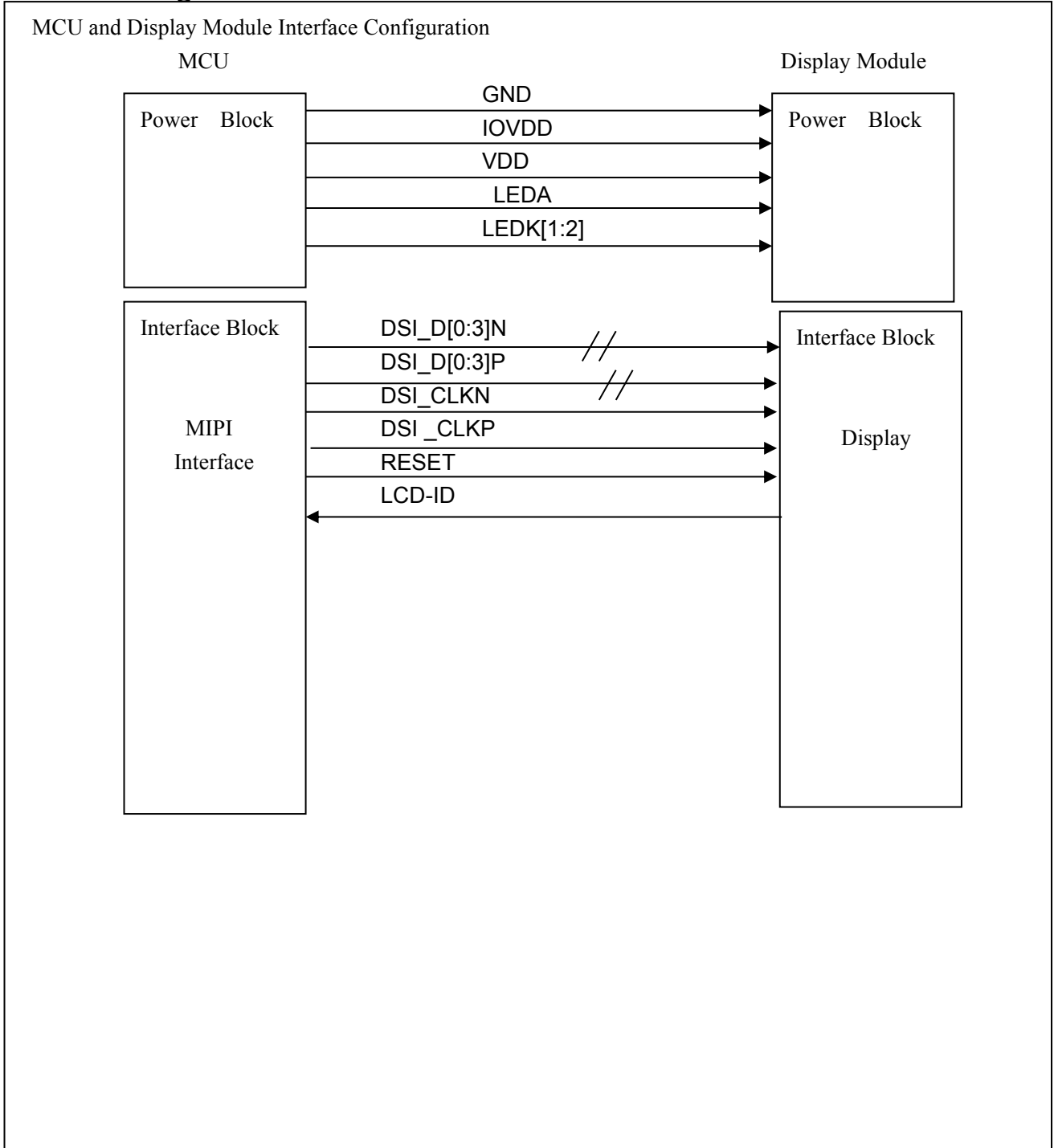



5. ELECTRICAL CHARACTERISTICS

5.1 Typical Operation Conditions

Item	Symbol	Values			Unit	Remarks
		Min.	Typ.	Max.		
Power Voltage Supply1	IOVDD	1.65	1.8	3.3	V	-
Power Voltage Supply2	VDD	2.65	2.8	3.3	V	
Luminance	Lv	-	400	-	cd/m2	
Backlight Forward Voltage	Vf	-	22.4	-	V	-
LED Forward Current	If	-	40	-	MA	Note

Note: The "LED life time" is defined as the module brightness decrease to 50% of original brightness at $I_L=20\text{mA}$ (for each led). The LED life time could be decreased if operating I_L is larger than 20mA

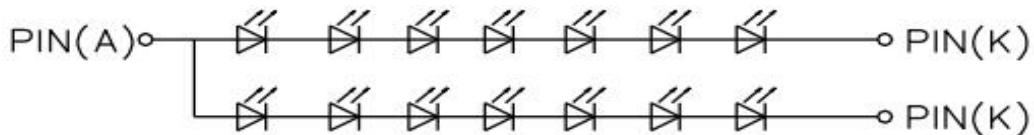

BACKLIGHT CIRCUIT DIAGRAM 20mA/LED (14LED)

LED Vf: 22.4V (TYP)

背光电路图
(CIRCUIT DIAGRAM)



5.2 DC CHARACTERISTICS

5.2.1 DC Characteristics for LCM

Parameter	Symbol	Conditions	Specification			Unit
			MIN	TYP	MAX	
Power supply voltage for MIPI Interface						
Power supply voltage for MIPI interface	VDDAM	-	1.65	1.8	3.6	V
	LVDSVDD	-	1.2	1.25	1.3	V
LPDT Input Characteristics						
Pad signal voltage range	VI	-	-50	-	1350	mV
Ground Shift	VGNSDH	-	-50	-	50	mV
Logic 0 input threshold	VIL	-	0	-	550	mV
Logic 1 input threshold	VIH	-	880	-	LVDSVDD	mV
Input hysteresis	VHYST	-	25	-	-	mV
LPDT Output Characteristics						
Output low level	VOL	-	-50	-	50	mV
Output high level	VOH	-	1.1	1.2	1.3	V
Logic 1 contention threshold	VILCD,MIN	-	450	-	LVDSVDD	mV
Logic 0 contention threshold	VIHCD,MAX	-	0	-	200	mV
Output impedance of LPDT	ZOLP	-	80	100	125	ohm
Hi-speed Input/Output Characteristics						
Single-end input low voltage	VILHS	-	-40	-	-	mV
Single-end input high voltage	VIHHS	-	-	-	460	mV
Common mode voltage	VCMRXDC	-	70	-	330	mV
Hi-speed transmit voltage	VOD	-	140	200	250	mV
Differential input impedance	ZID	-	80	100	125	ohm

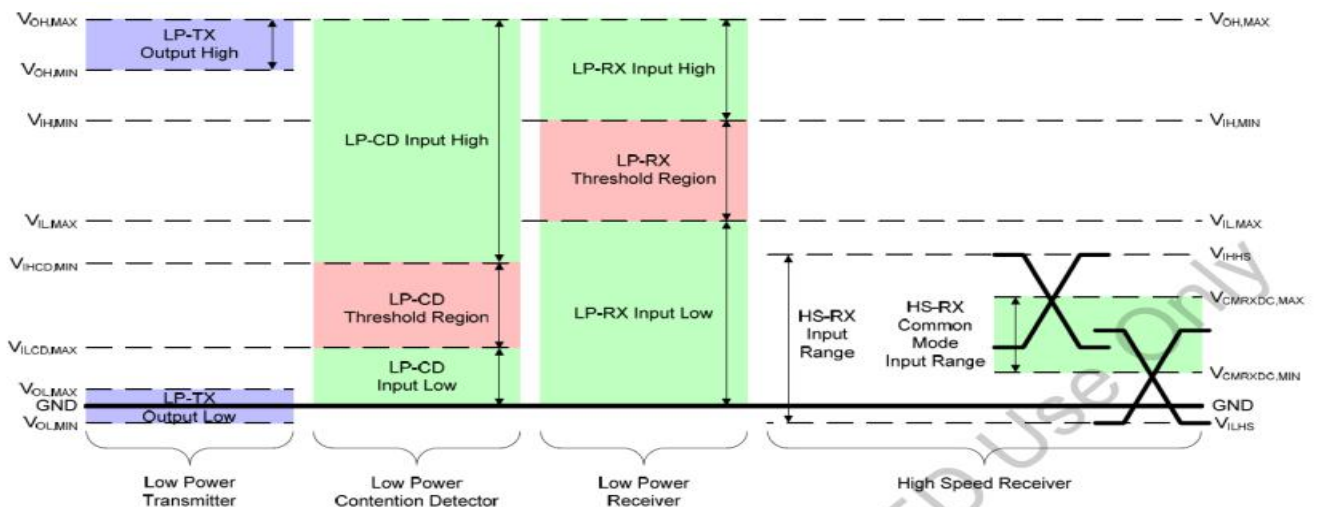



5.3 CTP AC CHARACTERISTICS

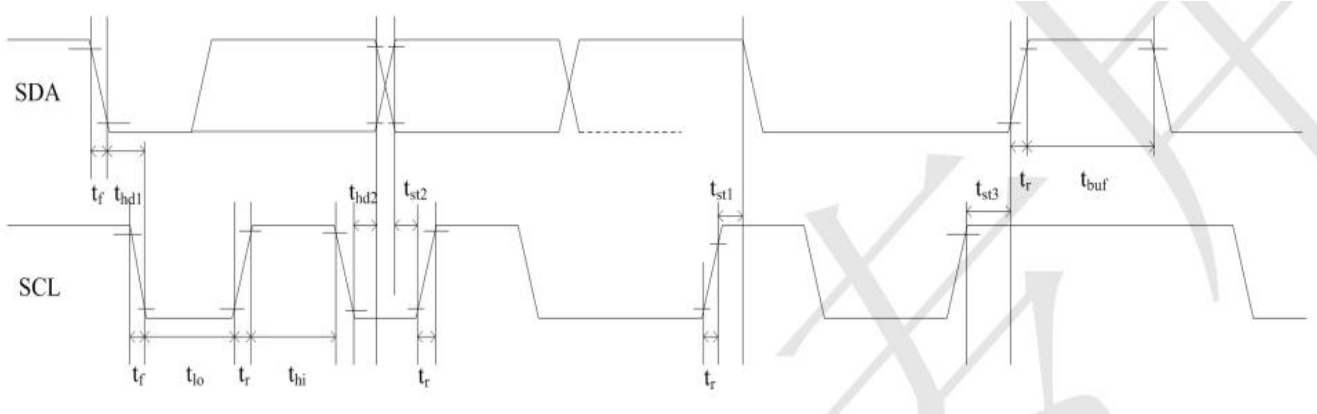

Parameter	Symbol	Min.	Max.	Unit
SCL low period	t_{io}	1.3	-	us
SCL high period	t_{hi}	0.6	-	us
SCL setup time for START condition	t_{st1}	0.6	-	us
SCL setup time for STOP condition	t_{st3}	0.6	-	us
SCL hold time for START condition	t_{hd1}	0.6	-	us
SDA setup time	t_{st2}	0.1	-	us
SDA hold time	t_{hd2}	0	-	us

Notes: 2.8V 通讯接口, 400Kbps 通讯速度, 上拉电阻 2K

5.4 LCM AC CHARACTERISTICS

Parameter	Symbol	Parameter	Specification			Unit
			MIN	TYP	MAX	
High Speed Mode						
DSI-CLK+/-	$2 \times UI_{INST}$	Double UI instantaneous	2	-	8	ns
DSI-CLK+/-	UI_{INSTA}, UI_{INSTB}	UI instantaneous Halfs	1	-	4	ns
DSI-Dn+/-	t_{DS}	Data to clock setup time	0.15	-	-	UI
DSI-Dn+/-	t_{DH}	Data to clock hold time	0.15	-	-	UI
DSI-CLK+/-	t_{DRTCLK}	Differential rise time for clock	150	-	0.3UI	ps
DSI-Dn+/-	$t_{DRTDATA}$	Differential rise time for data	150	-	0.3UI	ps
DSI-CLK+/-	t_{DFTCLK}	Differential fall time for clock	150	-	0.3UI	ps
DSI-Dn+/-	$t_{DFTDATA}$	Differential fall time for data	150	-	0.3UI	ps

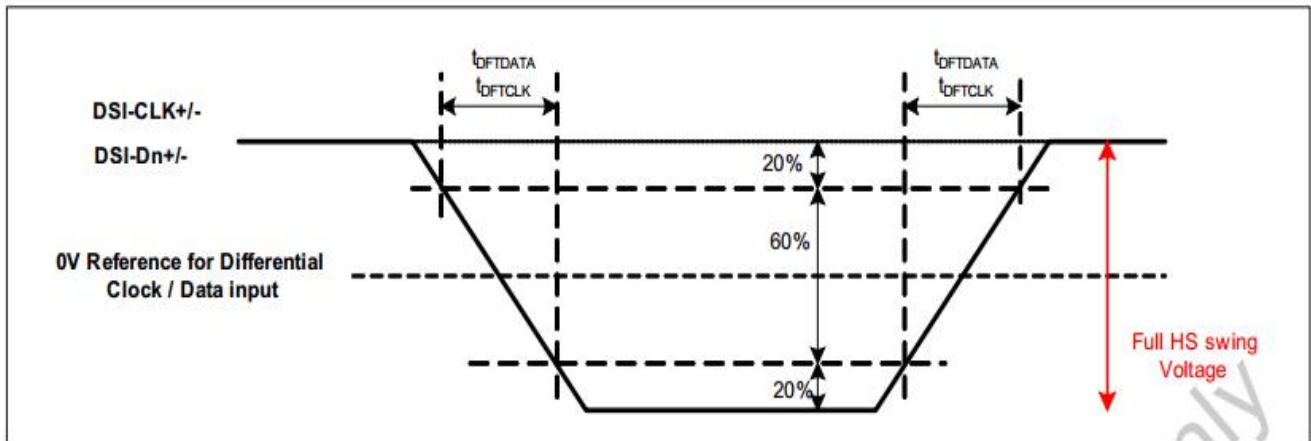
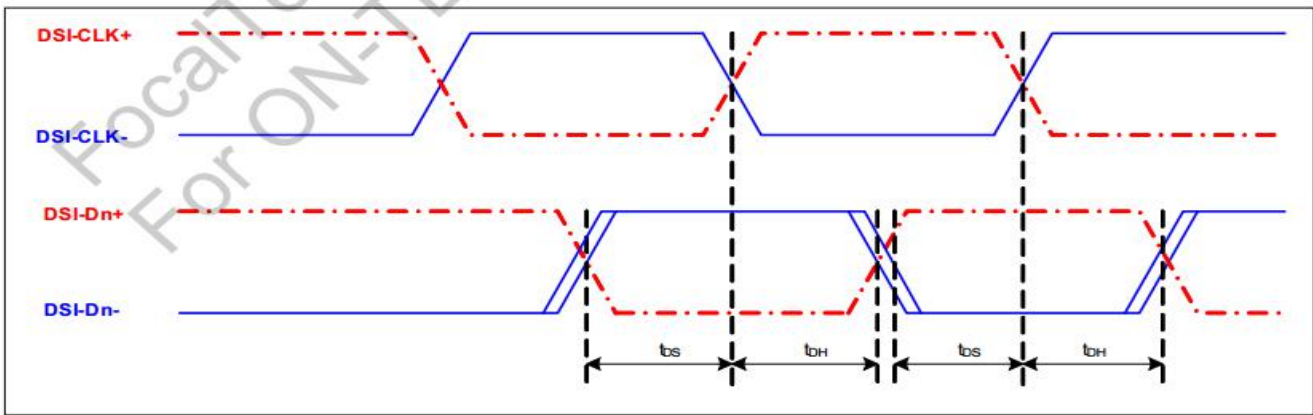
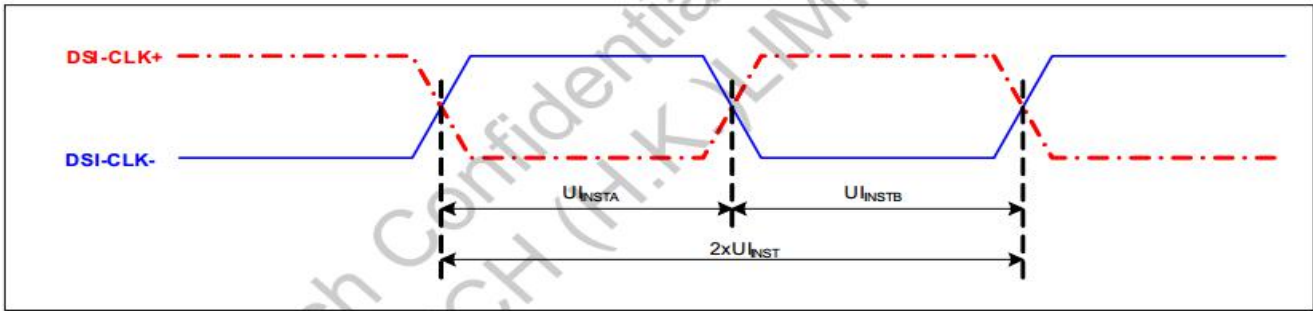



5.5 Power ON/OFF Sequence 电源开关序列

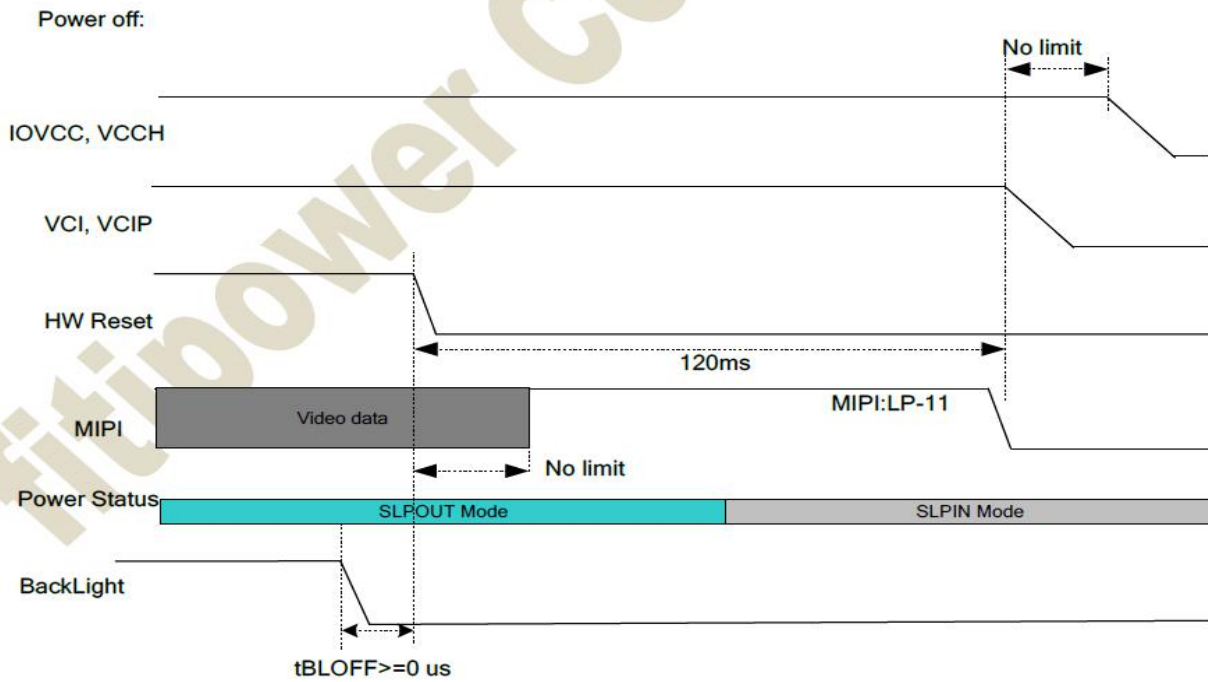
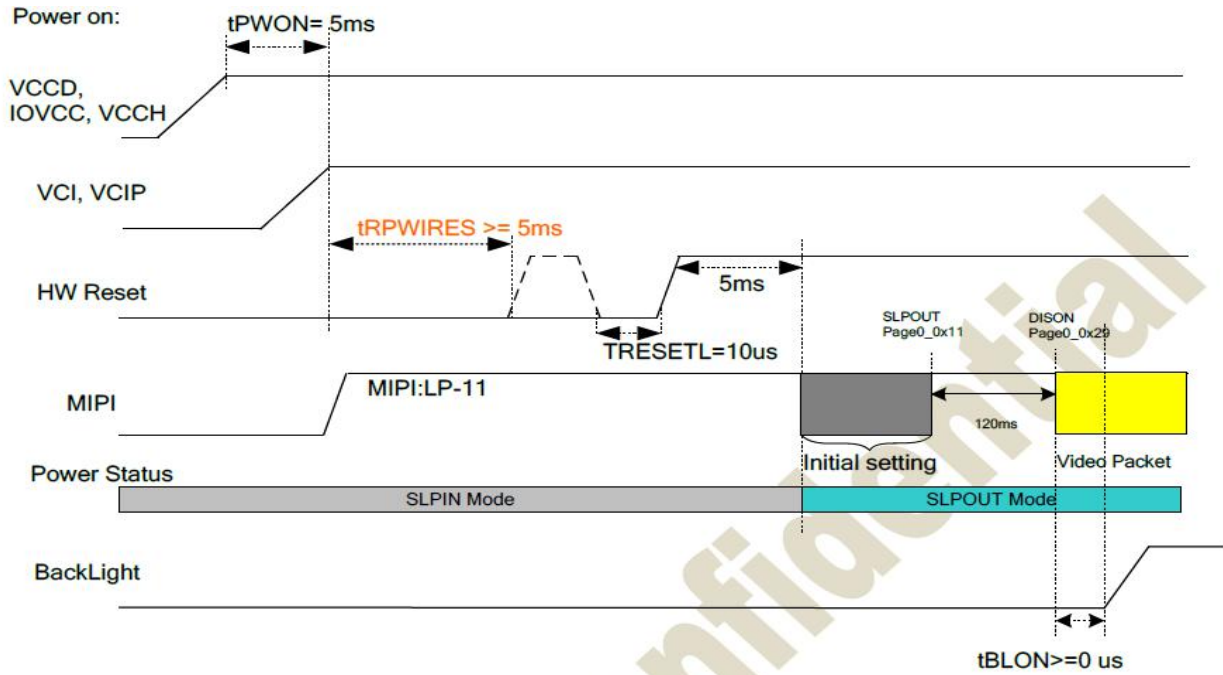



6. ELECTRO-OPTICAL CHARACTERISTICS

Parameter		Symbol	Condition	Min.	Typ.	Max.	Unit	Note
Contrast Ratio (Center point)		C/R	-	1000	1500	-	-	Note(1)
Luminance uniformity		U _w	θ = 0. Normal viewing angle B/L On Note(1)	80	85	-	%	Note(3)
Response Time		Tr + Tf		-	35	40	ms	Note(2)
Color Chromaticity (CIE 1931)	White	W _x		-0.02	+0.02	0.298	Note(5)	
		W _y	0.334					
	Red	R _x	0.659					
		R _y	0.319					
	Green	G _x	0.276					
		G _y	0.599					
	Blue	B _x	0.137					
		B _y	0.101					
Viewing Angle	Hor.	∅ 3R	C/R≥10	-	85	-	Deg	Note(4)
		∅ 9L			85			
	Ver.	∅ 12U			85			
		∅ 6D			-			



Note1 Definition of Contrast Ratio (CR):

$$\text{Contrast ratio (CR)} = \frac{\text{Luminance measured when LCD on the "White" state}}{\text{Luminance measured when LCD on the "Black" state}}$$

Note2: Definition of Response time: Sum of Tr and Tf

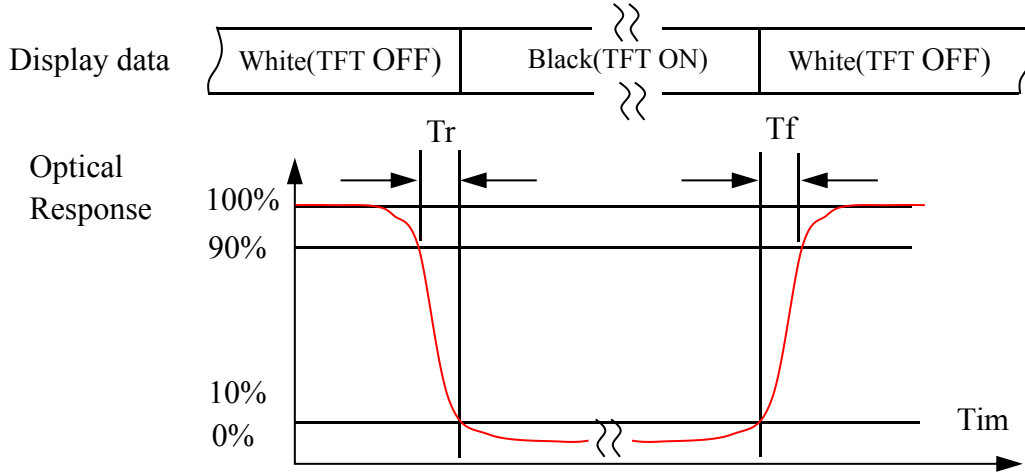

Note 3: Definition of Luminance Uniformity: Active area is divided into 9 measuring areas (Shown in below), every measuring point is placed at the center of each measuring area.

$$\text{Luminance Uniformity} = \frac{\text{Min Luminance of white among 9-points}}{\text{Max Luminance of white among 9-points}} \times 100\%$$

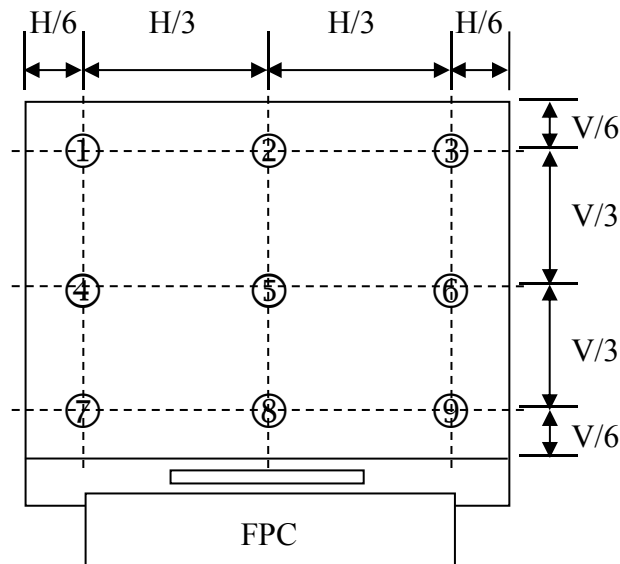

The spot locations for luminance measurement



Note4. Definition of Viewing Angle: The viewing angle range that the $CR \geq 10$

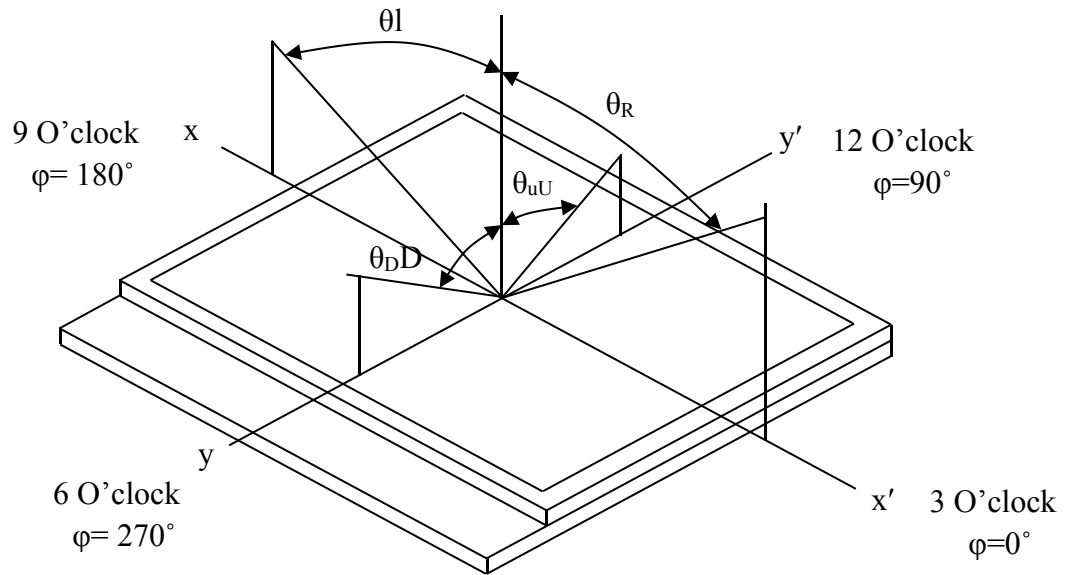

Note 5: Definition of Color Chromaticity (CIE 1931)

Color coordinate of white & red, green, blue at center point.



7. RELIABILITY TEST CONDITIONS

No 序号	Test Item	Test Condition
1	High Temperature Storage	+70°C / 24Hours
2	Low Temperature Storage	-20°C / 24Hours
3	High Temperature Operating	+60°C / 24Hours
4	Low Temperature Operating	-10°C / 24Hours
5	Temperature Cycle	-20 ⇄ 0°C ⇄ 70°C x 10cycles (30min) (5min) (30min)
6	Damp Proof Test	70°C x 90%RH / 24H
7	Vibration Test	Frequency: 10Hz~55Hz~10Hz Amplitude: 1.5mm, 2 hours for each direction of X, Y, Z
8	Dropping test	Drop to the ground from 1m height, 1 corner, 3 edges, 6 surfaces.
9	ESD test	Contact: ±6KV Air: ±10KV 150PF/330Ω, 5Points/panel, 5times

Inspection after test 判断标准

- The test samples should be applied to only one test item. 每个被测试的模块只能用于其中的一个测试项目。
- Sample size for each test item is 5~10pcs. 每个测试项目的样品数量为5~10片。
- For Damp Proof Test, Pure water (Resistance > 10MΩ) should be used. 对于防潮试验, 试验箱的用水必须是电阻大于10M 欧姆的纯水。
- In case of malfunction defect caused by ESD damage, if it would be recovered to normal state after resetting, it would be judged as a good part. 如果由静电引起产品故障, 当放置一段时间后能够恢复正常, 则不视为产品缺陷。
- EL evaluation should be excepted from reliability test with humidity and temperature: Some defects such as black spot/blemish can happen by natural chemical reaction with humidity and Fluorescence EL has. 带EL片的可靠性测试在高温高湿条件下, 荧光粉会发生自然化学反应而产生黑点或瑕疵, 因此不在高温高湿条件测试范围内。
- Failure Judgment Criterion: Basic Specification, Electrical Characteristic, Mechanical Characteristic, Optical Characteristic. 故障判断标准: 基本规格, 电气特性, 机械特性, 光电特性



8. PACKAGE DRAWING

