



SPEC. NUMBER	PRODUCT GROUP	REV.	ISSUE DATE	PAGE
	TFT-LCD	P0	2023.08.30	1 OF 25

LCM Product Specification

PV05036B0140H

ITEM	BUYER SIGNATURE	DATE
_____	<u>Carl</u>	<u>2023.09.04</u>
_____	<u>Jacky</u>	<u>2023.09.04</u>
_____	_____	_____

ITEM	SUPPLIER SIGNATURE	DATE
Prepared	_____	_____
Reviewed	_____	_____
Approved	_____	_____



SPEC. NUMBER

PRODUCT GROUP

REV.

ISSUE DATE

PAGE

TFT-LCD

P0

2023.08.30

3 OF 25

Contents

No.	Items	Page
1.0	General Description	4
2.0	Absolute Maximum Ratings	6
3.0	Electrical Specifications	7
4.0	Optical Specifications.	12
5.0	Mechanical Characteristics	16
6.0	Reliability	18
7.0	Packing	19
8.0	Product Lable	21
9.0	Precautions	22



SPEC. NUMBER	PRODUCT GROUP	REV.	ISSUE DATE	PAGE
	TFT-LCD	P0	2023.08.30	4 OF 25

1.0 GENERAL DESCRIPTION

1.1 Introduction

The PV05036B0140H model is a color TFT LCM without touch panel. This module has 5.0 inch diagonally measured active area with WVGA (800 horizontal by 480 vertical pixel array). Each pixel is divided into red, green, blue dots which are arranged in vertical stripe and this module can display 16.7M colors.



SPEC. NUMBER	PRODUCT GROUP	REV.	ISSUE DATE	PAGE
	TFT-LCD	P0	2023.08.30	5 OF 25

1.2 General Specification

Table 1-1 General Specifications

Parameter	Specification	Unit	Remarks
Active area	108 (H) × 64.8(V)	mm	5:3
Number of pixels	800(H) × 480(V)	pixels	
Pixel pitch	0.135(H) × 0.135 (V)	mm	
Pixel arrangement	RGB Vertical stripe		
Display colors	16.7M	colors	
Color gamut	40%@Transmissive, 16.5%@Reflective	%	Typ.
Display mode	Normally Black , Transflective		
Module outline	120.70(H) x 75.80(V) x 5.0	mm	w/o. component
Viewing Direction (Human Eye)	U/D/L/R Trans: Typ. 60/60/60/50 (CR > 2) Ref: Typ. 70/60/70/60 (CR > 2)	Deg.	Note1
Surface coating	-		

Note:

1. At the U/D/L/R direction, the viewing angle is same;



SPEC. NUMBER	PRODUCT GROUP	REV.	ISSUE DATE	PAGE
	TFT-LCD	P0	2023.08.30	6 OF 25

2.0 ABSOLUTE MAXIMUM RATINGS

The followings are maximum values which, if exceed, may cause faulty operation or damage to the unit. The operational and non-operational maximum voltage and current values are listed in Table 2.

< Table 2. Absolute Maximum Ratings >

Parameter		Symbol	Min.	Max.	Unit	Remarks
Power Supply	LCD Module	VCC	0	3.6	V	Ta = 25 °C
	BLU	V _{LED}	-	19.2	V	
		I _{LED}	-	80	mA	
Operating Temperature		T _{OP}	-30	+85	°C	Note 1
Storage Temperature		T _{ST}	-30	+85	°C	

Note : 1) Temperature and relative humidity range are shown in the figure below.

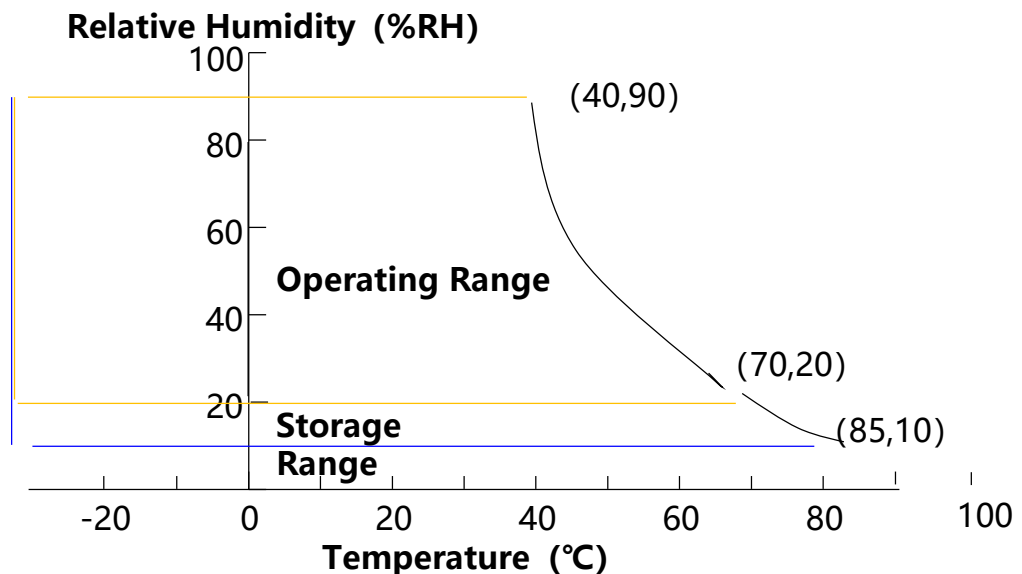



SPEC. NUMBER	PRODUCT GROUP	REV.	ISSUE DATE	PAGE
	TFT-LCD	P0	2023.08.30	7 OF 25

3.0 ELECTRICAL SPECIFICATIONS

3.1 Typical operation conditions

Item	Symbl	Min	Typ	Max	Uint	Remark
Supply power voltage	VCC	3.0	3.3	3.6	V	TTL mode
I/O power voltage	IOVCC	3.0	3.3	3.6	V	
Votp	VOTP	7.5	7.75	8	V	

Backlight

Item	Symbl	Min	Typ	Max	Uint	Remark
LED Current	I_F	-	60	-	mA	note
LED Voltage	V_F	-	18.6	-	V	
LED Life Time	W_{BL}	25000			Hr	

note

$T_a=25^{\circ}C$

LED life time: brightness to be decreased to 50% of the initial value

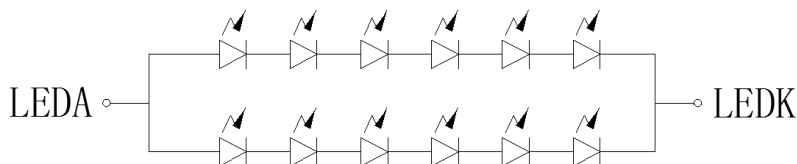

$$I_f=30*2mA , V_f=18.6V \text{ REF}$$



SPEC. NUMBER	PRODUCT GROUP	REV.	ISSUE DATE	PAGE
	TFT-LCD	P0	2023.08.30	8 OF 25

3.0 ELECTRICAL SPECIFICATIONS

3.2 The LCD Module Electrical Interface Connection

Table 3-1 Pin Assignments for the LCD

Pin No	Definition	Description
1	LEDK	Backlight LED cathode
2	LEDA	Backlight LED anode
3	GND	Ground
4	VCC	Power supply(3.3V.typ)
5-12	R0-R7	data bus
13-20	G0-G7	data bus
21-28	B0-B7	data bus
29	GND	Ground
30	CLK	Pixel clock signal
31	DISP	Display on/off control (H: on, L/NC: off)
32	HSYNC	Horizontal Sync signal
33	VSYNC	Vertical Sync signal
34	DEN	Data Enable
35	NC	No connect
36	GND	Ground
37	NC	No connect
38	NC	No connect
39	NC	No connect
40	NC	No connect



SPEC. NUMBER	PRODUCT GROUP	REV.	ISSUE DATE	PAGE
	TFT-LCD	P0	2023.08.30	9 OF 25

3.3 RGB Interface

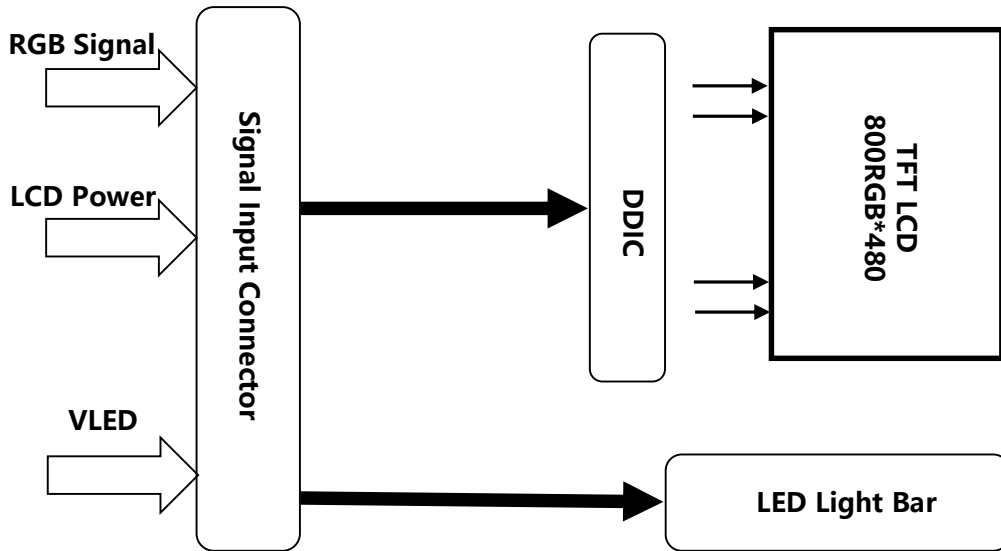



SPEC. NUMBER	PRODUCT GROUP	REV.	ISSUE DATE	PAGE
	TFT-LCD	P0	2023.08.30	10 OF 25

3.4 Power Sequence

Power On Sequence

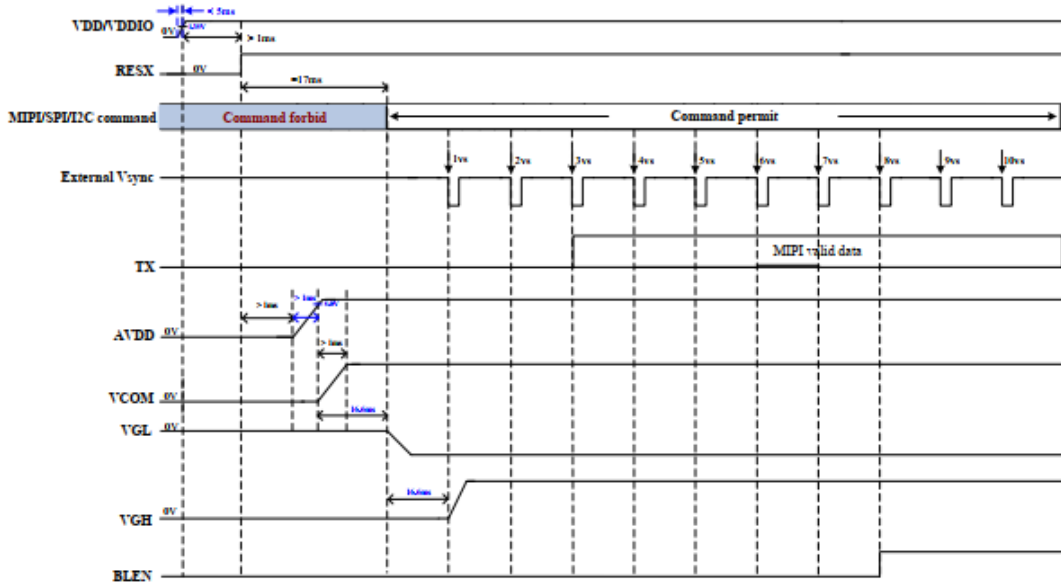

Figure : Power On timing chart

Power Off Sequence

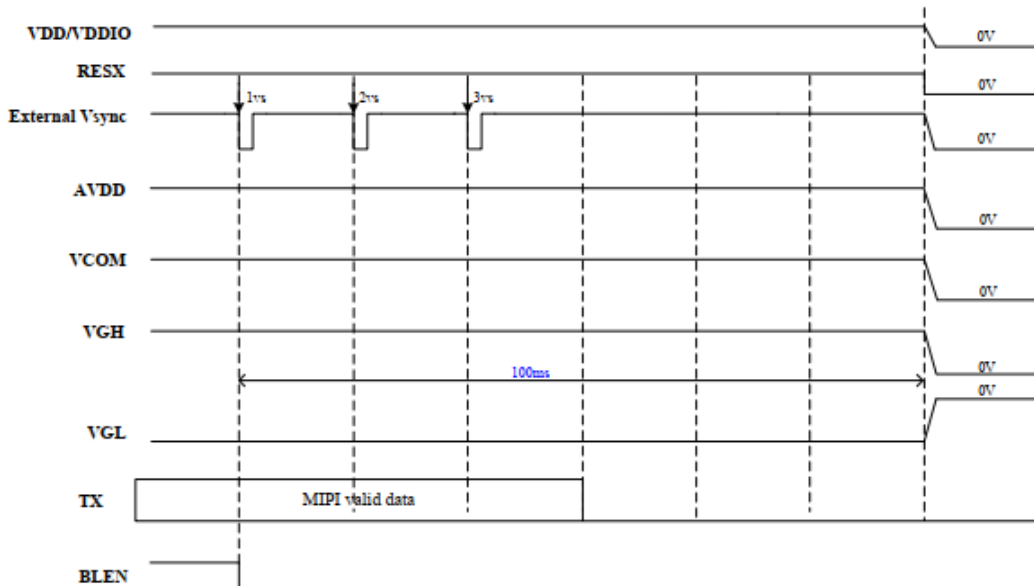

Figure : Power Off timing chart



SPEC. NUMBER	PRODUCT GROUP	REV.	ISSUE DATE	PAGE
	TFT-LCD	P0	2023.08.30	11 OF 25

3.4 TTL INPUT TIMING

● Horizontal timing

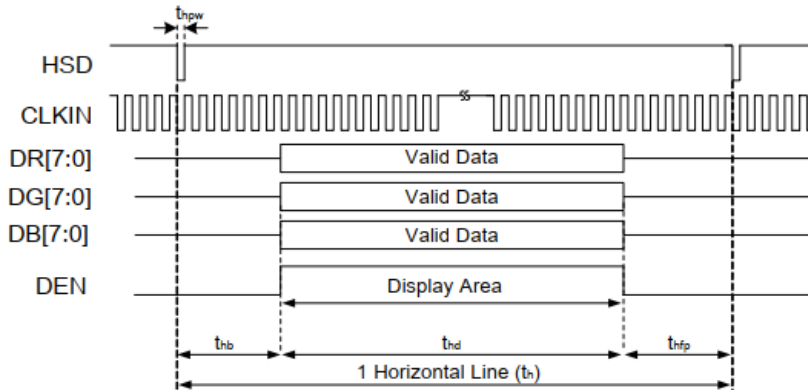

● Vertical timing

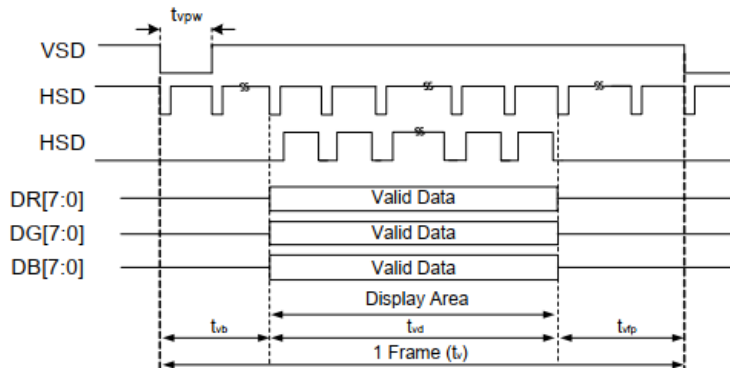

Figure : 24-bit parallel RGB mode horizontal/vertical input timing

24-bit parallel RGB In put Timing	Symbol	800RGBx480			Unit
		Min	Typ	Max	
DCLK Frequency	f_{xclk}	29	32.4	37.6	MHZ
Horizontal Display Area	t_{hd}		800		DCLK
HS Pulse width	t_{hpw}	4	24	HBP-1	DCLK
HS Back Porch	t_{hbp}	62	160	200	DCLK
HS Front Porch	t_{hfp}	38	40	100	DCLK
1 Horizontal Line	t_h	900	1000	1100	DCLK
Vertical Display Area	t_{vd}		480		THT
VS Pulse Width	t_{vpw}	2	2	VBP-1	THT
VS Back Porch	t_{vbp}	12	23	35	THT
VS Front Porch	t_{vfp}	12	37	55	THT
1 Vertical field	t_v	504	540	570	THT
FRAME Rate	-		60		Hz



SPEC. NUMBER	PRODUCT GROUP	REV.	ISSUE DATE	PAGE
	TFT-LCD	P0	2023.08.30	12 OF 25

4.0 OPTICAL SPECIFICATIONS

4.1 Overview

The test of Optical specifications shall be measured in a dark room (ambient luminance ≤ 1 lux and temperature = $25 \pm 2^\circ\text{C}$) with the equipment of Luminance meter system (Goniometer system and TOPCON BM-7) and test unit shall be located at an approximate distance 50cm from the LCD surface at a viewing angle of θ and Φ equal to 0° . The center of the measuring spot on the Display surface shall stay fixed.

The backlight should be operating for 30 minutes prior to measurement.

Table 4-1 Optical Specifications (Transmissive)

Parameter		Symbol	Condition	Min.	Typ.	Max.	Unit	Remark
Viewing Angle range	Horizontal	Θ_3	CR > 2	-	50	-	Deg.	Note 1
		Θ_9		-	60	-	Deg.	
	Vertical	Θ_{12}		-	60	-	Deg.	
		Θ_6		-	60	-	Deg.	
Luminance Contrast ratio		CR	$\Theta = 0^\circ$ (Center) Normal Viewing Angle	-	60	-		Perpendicular
White luminance uniformity		ΔY		80			%	Note 4
NTSC		%		-	40		%	
White Chromaticity		x_w		Typ-0.03	Typ+0.03	0.310	-	Simulation result, we will try to close to CTP white coordinate. Actual value will be updated after samples be tested. Note 5
		y_w	0.300			-		
Reproduction of color	Red	x_R	0.581			-		
		y_R	0.347			-		
	Green	x_G	0.365			-		
		y_G	0.547			-		
	Blue	x_B	0.171			-		
		y_B	0.119			-		
Response Time (Rising / Falling)		T_{RT}	25°C	-	20	25	ms	Note 6
Brightness		YL		-	200		Cd/cm ²	



SPEC. NUMBER	PRODUCT GROUP	REV.	ISSUE DATE	PAGE
	TFT-LCD	P0	2023.08.30	13 OF 25

Table 4-2 Optical Specifications (Reflective)

Parameter		Symbol	Condition	Min.	Typ.	Max.	Unit	Remark	
Viewing Angle range	Horizontal	Θ_3	CR > 2	-	60	-	Deg.	Note 1	
		Θ_9		-	70	-	Deg.		
	Vertical	Θ_{12}		-	70	-	Deg.		
		Θ_6		-	60	-	Deg.		
Luminance Contrast ratio		CR	$\Theta = 0^\circ$ (Center) Normal Viewing Angle	-	7	-		Perpendicular	
NTSC		%		-	16.5	-	%		
White Chromaticity		X_w		Typ-0.03	0.314	Typ+0.03	-	@D65 Light	
		Y_w					-		
Reproduction of color	Red	X_R					0.456		-
		Y_R					0.342		-
	Green	X_G					0.304		-
		Y_G					0.479		-
	Blue	X_B					0.192		-
		Y_B					0.220		-

Note :

- Viewing angle is the angle at which the contrast ratio is greater than 10. The viewing are determined for the horizontal or 3, 9 o'clock direction and the vertical or 6, 12 o'clock direction with respect to the optical axis which is normal to the LCD surface.
- Contrast measurements shall be made at viewing angle of $\theta = 0^\circ$ and at the center of the LCD surface. Luminance shall be measured with all pixels in the view field set first to white, then to the dark (black) state. (See FIGURE 1 shown in Appendix)
Luminance Contrast Ratio (CR) is defined mathematically.

$$CR = \frac{\text{Luminance when displaying a white raster}}{\text{Luminance when displaying a black raster}}$$

- Center trans of white is defined as the LCD surface. Luminance shall be measured with all pixels in the view field set first to white. This measurement shall be taken at the locations shown in FIGURE 4 for a total of the measurements per display.
- The White luminance uniformity on LCD surface is then expressed as :
 $\Delta Y = (\text{Minimum Luminance of 9points} / \text{Maximum Luminance of 9points}) * 100$
- The color chromaticity coordinates specified in Table 4. shall be calculated from the spectral data measured with all pixels first in red, green, blue and white. Measurement condition is C- light source.
- The electro-optical response time measurements shall be made as FIGURE 5 shown in Appendix by switching the "data" input signal ON and OFF. The times needed for the transmittance to change from 10% to 90% is T_r , and 90% to 10% is T_f .



SPEC. NUMBER	PRODUCT GROUP	REV.	ISSUE DATE	PAGE
	TFT-LCD	P0	2023.08.30	14 OF 25

4.2 OPTICAL TEST APPENDIX

Figure 4-1 The Definition of V_{th} & V_{sat}

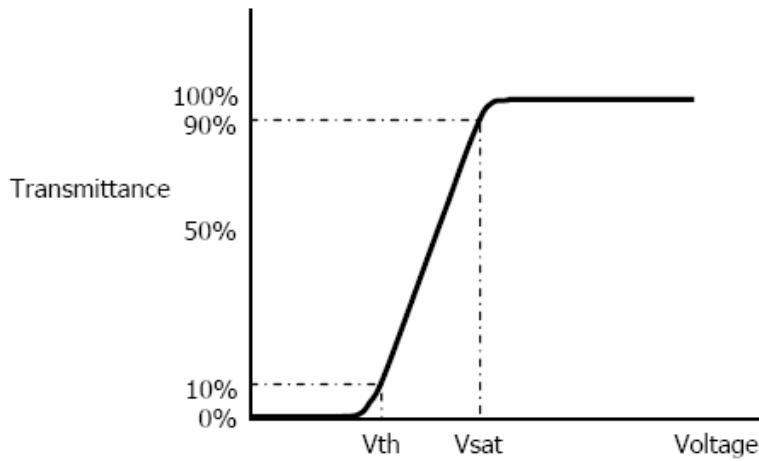
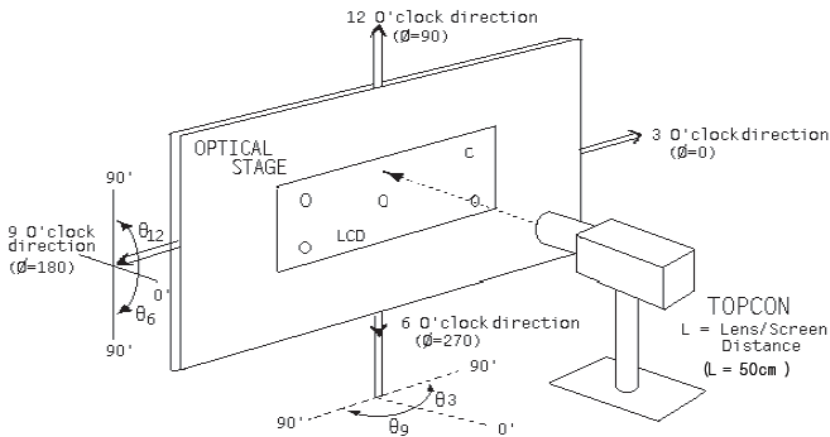

Figure 4-2 Measurement Set Up





SPEC. NUMBER	PRODUCT GROUP	REV.	ISSUE DATE	PAGE
	TFT-LCD	P0	2023.08.30	15 OF 25

Figure 4-3 Response Time Testing

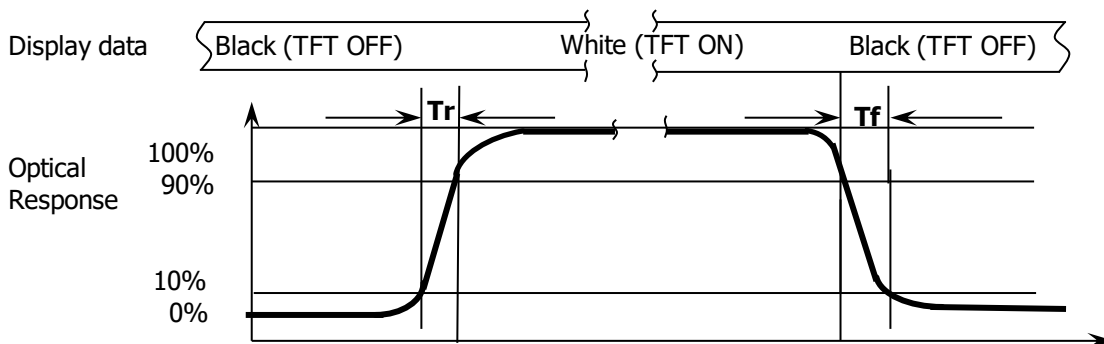



SPEC. NUMBER	PRODUCT GROUP	REV.	ISSUE DATE	PAGE
	TFT-LCD	P0	2023.08.30	16 OF 25

5.0 MECHANICAL CHARACTERISTICS

5.1 Dimensional Requirements

Figure in next page shows mechanical outlines for the panel.

Table 5-1 Dimensional Parameters

Parameter	Specification	Unit
Active Area	108 (H) × 64.8(V)	mm
Number of pixels	800(H) × 480(V)	Pixels
Pixel pitch	0.135(H) × 0.135 (V)	mm
Pixel arrangement	RGB Vertical stripe	
Display colors	16.7M	colors
Display mode	Normally Black, Transflective	
Module thickness	5.0 **	mm
Module outline	120.70*75.80	mm
AA-MDL outline L/R/U/D	6.35 / 6.35 / 3.34 / 7.66	mm

** w./o. component



SPEC. NUMBER	PRODUCT GROUP	REV.	ISSUE DATE	PAGE
	TFT-LCD	P0	2023.08.30	17 OF 25

5.2 Outline Dimension

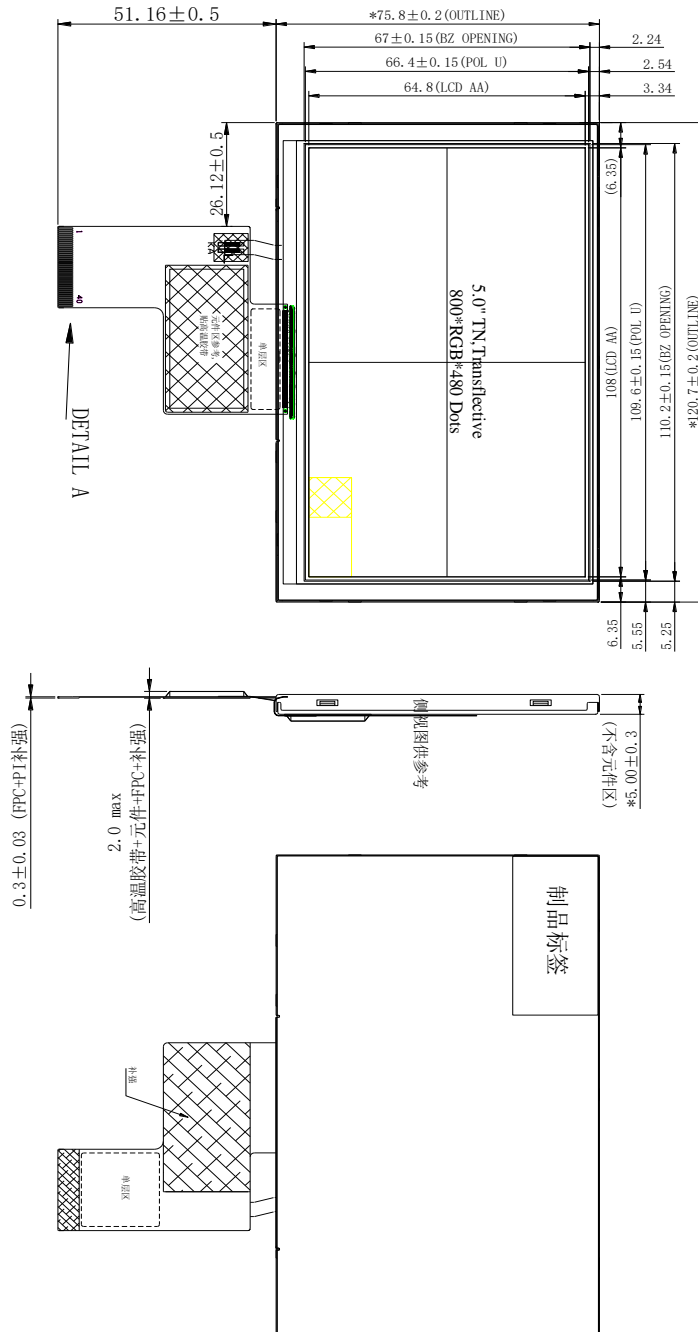



SPEC. NUMBER	PRODUCT GROUP	REV.	ISSUE DATE	PAGE
	TFT-LCD	P0	2023.08.30	18 OF 25

6.0 RELIABILITY

Table 6-1 Reliability test

No	Test Items	Conditions	Remark
1	High temperature storage test	Ta = +85 °C, 240 hrs	
2	Low temperature storage test	Ta = -30°C, 240 hrs	
3	High temperature operation test	Ta = +85°C, 240 hrs	
4	Low temperature operation test	Ta = -30 °C, 240 hrs	
5	High temperature & high humidity (operation test)	Ta = +60 °C, 90%RH, 240 hrs	
6	Thermal shock	-20°C 30 min ~ +70°C 30 min , Change time: 5min, 100 Cycle	Non-operation
7	ESD test	330Ω/150pF, Contact: ±4K Air: ±8K, class B	

Note: After the reliability test, the product only guarantee function normally without any fatal defect (non-display, line defect, abnormal display etc). All the cosmetic specification is judged before the reliability test.



SPEC. NUMBER	PRODUCT GROUP	REV.	ISSUE DATE	PAGE
	TFT-LCD	P0	2023.08.30	19 OF 25

7.0 Packing (Tentative)

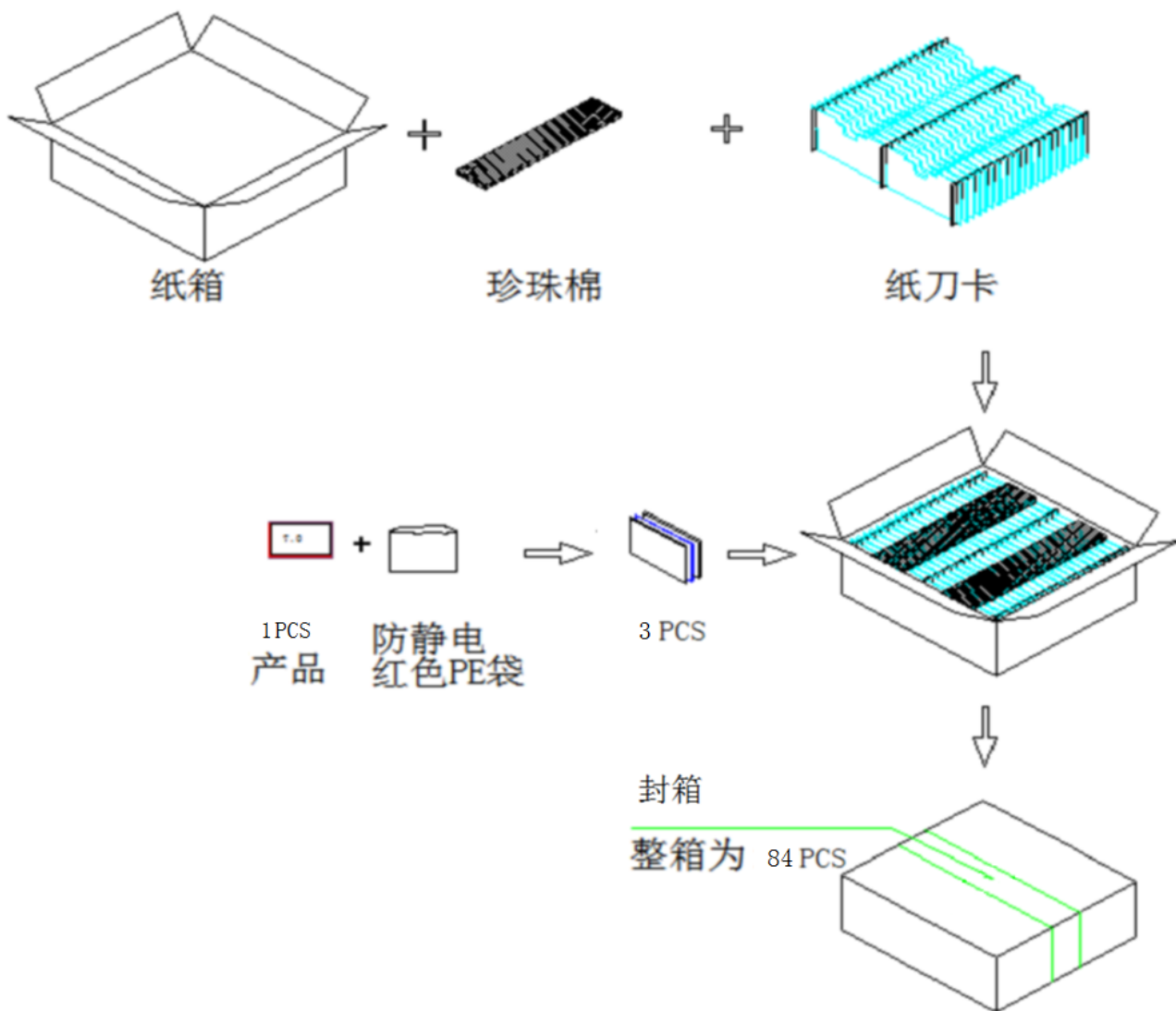



SPEC. NUMBER	PRODUCT GROUP	REV.	ISSUE DATE	PAGE
	TFT-LCD	P0	2023.08.30	20 OF 25

Box label (产品形态: LCM)

- Label Size :110mm*55mm
- Contents
 1. FG-CODE (First 12 digits)
 2. Product Quantity
 3. Serial No. : Box Serial No. as shown below.
 4. Date : Packing Date
 5. FG-Code (Last 4 digits)

No.	1	2	3	4	5	6	7	8	9	10	11	12	13
Code	X	X	A	3	*	*	*	0	*	*	*	*	*
	GBN		Grade	B3	Year		Month	Rev	Serial number (base-32)				



SPEC. NUMBER	PRODUCT GROUP	REV.	ISSUE DATE	PAGE
	TFT-LCD	P0	2023.08.30	21 OF 25

8.0 Product Label

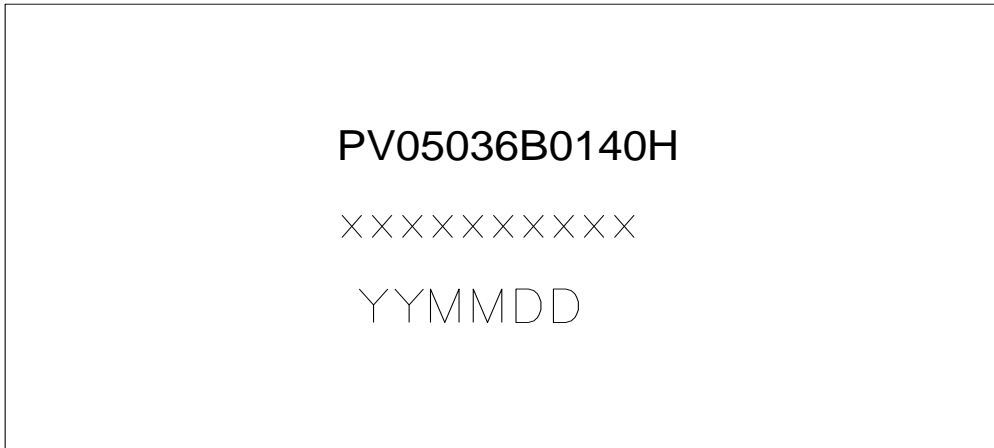

Label Size : 40mm*20mm

• Contents

1. FG-CODE (First 12 digits) PV05036B0140H
2. Serial No. : (12 digits).
- 3 MFG : YYMMDD

QR code: 1+2+3



SPEC. NUMBER	PRODUCT GROUP	REV.	ISSUE DATE	PAGE
	TFT-LCD	P0	2023.08.30	22 OF 25

9.0 PRECAUTIONS

9.1 Handing

- (1) Use fingerstalls with soft gloves in order to keep display clean during the incoming inspection and assembly process.
- (2) You must mount a module using specified mounting holes (Details refer to the drawings).
- (3) Please make sure to avoid external forces applied to the Source FPC and D-IC during the process of handling or assembling. If not, It causes panel damage or malfunction.
- (4) Note that polarizers are very fragile and could be easily damaged. Do not touch, push or rub the exposed polarizers with glass, tweezers or anything harder than HB pencil lead. And please do not rub with dust clothes with chemical treatment.
- (5) Do not pull or fold the source D-IC which connect the source FPC and the panel. Do not pull or fold the LED wire.
- (6) After removing the protective film, when the surface becomes dusty, please wipe gently with absorbent cotton or other soft materials like chamois soaks with alcohol or purified water. Do not strong polar solvent because they cause chemical damage to the polarizer
- (7) Wipe off saliva or water drops as soon as possible. Their long time contact with . polarizer causes deformations and color fading.
- (8) Protection film for polarizer on the module shall be slowly peeled off just before use so that the electrostatic charge can be minimized.
- (9) Since the LCD is made of glass, do not apply strong mechanical impact or static load onto it. Handling with care since shock, vibration, and careless handling may seriously affect the product. If it falls from a high place or receives a strong shock, the glass may be broken.
- (10) Do not disassemble the module.
- (11) To determine the optimum mounting angle, refer to the viewing angle range in the specification for each model.
- (12) If the customer's set presses the main parts of the LCD, the LCD may show the abnormal display. But this phenomenon does not mean the malfunction of the LCD and should be pressed by the way of mutual agreement.
- (13) Do not drop water or any chemicals onto the LCD's surface.
- (14) The ITO pad area needs special careful caution because it could be easily corroded. Do not contact the ITO pad area with HCFC, Soldering flux, Chlorine, Sulfur, saliva or fingerprint. To prevent the ITO corrosion, customers are recommended that the ITO area would be covered by UV or silicon.



SPEC. NUMBER	PRODUCT GROUP	REV.	ISSUE DATE	PAGE
	TFT-LCD	P0	2023.08.30	23 OF 25

9.2 Operating Precautions

- (1) Be careful for condensation at sudden temperature change. Condensation makes damage to polarizer or electrical contacted parts. And after fading condensation, smear or spot will occur.
- (2) Module has high frequency circuits. Sufficient suppression to the electromagnetic interference shall be done by system manufacturers. Grounding and shielding methods may be important to minimized the interference.
- (3) The electrochemical reaction caused by DC voltage will lead to LCD degradation, so DC drive should be avoided.
- (4) The LCD modules use C-MOS LSI drivers, so customers are recommended that any unused input terminal would be connected to Vdd or Vss, do not input any signals before power is turn on, and ground you body, work/assembly area, assembly equipments to protect against static electricity.
- (5) Do not exceed the absolute maximum rating value. (supply voltage variation, input voltage variation, variation in part contents and environmental temperature, and so on) Otherwise the Module may be damaged.
- (6) Design the length of cable to connect between the connector for back-light and the converter as short as possible and the shorter cable shall be connected directly. The longer cable between that of back-light and that of converter may cause the luminance of LED to lower and need a higher startup voltage(Vs).
- (7) Connectors are precise devices for connecting PCB and transmitting electrical signals. Operators should insert and unplug MDL in parallel when assembling MDL.
- (8) Do not connect or disconnect the cable to/ from the module at the "Power On" condition.
- (9) When the module is operating, do not lose CLK, HS, VS signals. If any one these signals is lost, the LCD panel would be damaged.
- (10) Obey the supply voltage sequence. If wrong sequence is applied, the module would be damaged.
- (11) Do not re-adjust variable resistor or switch etc.



SPEC. NUMBER	PRODUCT GROUP	REV.	ISSUE DATE	PAGE
	TFT-LCD	P0	2023.08.30	24 OF 25

9.3 Electrostatic Discharge Control

- (1) Since a module is composed of electronic circuits, it is not strong to electrostatic discharge. Make certain that treatment persons are connected to ground through wrist band etc. And don't touch interface pin directly. Keep products as far away from static electricity as possible.
- (2) Avoid the use work clothing made of synthetic fibers. We recommend cotton clothing or other conductivity-treated fibers.

9.4 Precautions for Strong Light Exposure

Strong light exposure causes degradation of polarizer and color filter. It is not allowed to store or run directly in strong light or in high temperature and humidity for a long time.

9.5 Storage Precautions

- (1) When storing the LCD modules, avoid exposure to direct sunlight or to the light of fluorescent lamps.
- (2) The LCD modules should be stored under the storage temperature range. the recommend condition is: Temperature : 0°C~ 40°C, Relatively humidity: ≤80%, and no more than 1 year.
- (3) The LCD modules should be stored in the room without acid, alkali and harmful gas.

9.6 Handling Precautions for Protection Film

- (1) Remove the protective film slowly, keeping the removing direction approximate 30-degree not vertical from panel surface, If possible, under ESD control device like ion blower, and the humidity of working room should be kept over 50%RH to reduce the risk of static charge.
- (2) In handling the LCD, wear non-charged material gloves. And the conducting wrist to the earth and the conducting shoes to the earth are necessary.

9.7 Operation Condition Guide

- (1) Lifetime in this spec. is guaranteed only when Commercial Display is used according to operating usages.
- (2) Module used in unnormal orientation mode , need to confirm with the manufacturer.
- (3) Do not exceed the absolute maximum rating value. (supply voltage variation, input voltage variation, variation in part contents and environmental temperature, and so on) Otherwise the Module may be damaged.



SPEC. NUMBER	PRODUCT GROUP	REV.	ISSUE DATE	PAGE
	TFT-LCD	P0	2023.08.30	25 OF 25

- (4) Dew drop atmosphere should be avoided.
- (5) The storage room should be equipped with a good ventilation facility, which has a temperature controlling system.
- (6) When expose to drastic fluctuation of temperature (hot to cold or cold to hot) ,the LCD may be affected; Specifically, drastic temperature fluctuation from cold to hot ,produces dew on the LCD's surface which may affect the operation of the polarizer and the LCD.
- (7) Response time will be extremely delayed at lower temperature than the operating temperature range and on the other hand at higher temperature LCD may turn black at temperature above its operational range. However those phenomena do not mean malfunction or out of order with the LCD. The LCD will revert to normal operation once the temperature returns to the recommended temperature range for normal operation.

9.8 Others

- (1)When returning the module for repair or etc., Please pack the module not to be broken. We recommend to use the original shipping packages.
- (2) If the liquid crystal material leaks from the panel, it should be kept away from the eyes or mouth. In case of contact with hands, legs or clothes, it must be washed away thoroughly with soap.
- (3) For the crash damaged or unnecessary LCD, it is recommended to wash off liquid crystalby either of solvents such as acetone and ethanol an should be burned up later.
- (4) If you should swallow the liquid crystal, first, wash your mouth thoroughly with water, then drink a lot of water and induce vomiting, and then, consult a physician.
- (5) If the liquid crystal should get in your eyes, flush your eyes with running water for at least fifteen minutes.
- (6) Client needs to add heat dissipation design , such as fan, water cooling , etc.
- (7) After assembling into modules, guarantee that the temperature rise of panel surface does not exceed 20°C at room temperature.
- (8) Customers need to drive current down according to derating curve.