



# PRODUCT SPECIFICATION

## 5.0" IPS TFT LCD MODULE

### MODEL: PV05035H0540G

<◆> Preliminary Specification

<◇> Finally Specification



CUSTOMER'S APPROVAL	
CUSTOMER :	
SIGNATURE:	DATE:

APPROVED BY	PM REVIEWED	PD REVIEWED	PREPARED BY

Revision History



Revision	Date	Originator	Detail	Remarks
1.0	20220713		Initial Release	
1.1	20230504		Change IC,Optimized circuit of FPC	



**Table of Contents**

No.	Item	Page
1.	General Description .....	5
2.	Module Parameter .....	5
3.	Outline Drawing .....	6
4.	Absolute Maximum Ratings .....	7
5.	DC Characteristics .....	8
6.	Backlight Characteristics .....	8
6.1.	Backlight Characteristics .....	8
6.2.	Backlighting circuit .....	8
7.	Optical Characteristics .....	9
7.1.	Optical Characteristics .....	9
7.2.	Definition of Response Time .....	9
7.3.	Definition of Contrast Ratio .....	10
7.4.	Definition of Viewing Angles .....	10
7.5.	Definition of Color Appearance .....	11
7.6.	Definition of Surface Luminance, Uniformity and Transmittance .....	11
8.	Block Diagram and Power Supply .....	12
9.	Interface Pins Definition .....	13
10.	AC Characteristics .....	14
10.1.	AC Timing characteristics .....	14
10.2.	Display Timing characteristics .....	15
10.3.	Power ON/Off Sequence .....	16
11.	Quality Assurance .....	17



11.1. Purpose .....	17
11.2. Standard for Quality Test .....	17
11.3. Nonconforming Analysis & Disposition .....	17
11.4. Agreement Items .....	17
11.5. Standard of the Product Visual Inspection .....	17
11.6. Inspection Specification .....	18
11.7. Classification of Defects .....	22
11.8. Identification/marketing criteria .....	22
11.9. Packing .....	23
12. Reliability Specification .....	24
13. Precautions and Warranty .....	25
13.1. Safety .....	25
13.2. Handling .....	25
13.3. Storage .....	25
13.4. Metal Pin (Apply to Products with Metal Pins) .....	25
13.5. Operation .....	26
13.6. Static Electricity .....	26
13.7. Limited Warranty .....	26
14. Packaging .....	27



## 1. General Description

The specification is a transmissive type color active matrix liquid crystal display (LCD) which uses amorphous thin film transistor (TFT) as switching devices. This product is composed of a TFT-LCD panel, driver lcs and a backlight unit.

## 2. Module Parameter

Features	Details	Unit
Display Size(Diagonal)	5.0"	
LCD type	IPS TFT	
Display Mode	Normally Black/Transmissive	
Resolution	800 RGB x 480	Pixels
View Direction	Full view	Best Image
Gray Scale Inversion Direction	/	
Module Outline	120.3 (H) x 75.35(V) x 2.6(T) (Note1 )	mm
Active Area	108 (H) x 64.8(V)	mm
Pixel Size	135 (H) x 135(V)	um
Pixel Arrangement	R.G.B Vertical Stripe	
Polarizer Surface Treatment	Anti-Glare	
Display Colors	16.7M	
Interface	24-bit RGB interface	
Driver IC	ST72568	-
With or Without Touch Panel	Without	
Operating Temperature	<b>-30~80</b>	°C
Storage Temperature	<b>-30~85</b>	°C
Weight	-	g

Note 1: Exclusive hooks, posts, FFC/FPC tail etc.



### 3. Outline Drawing

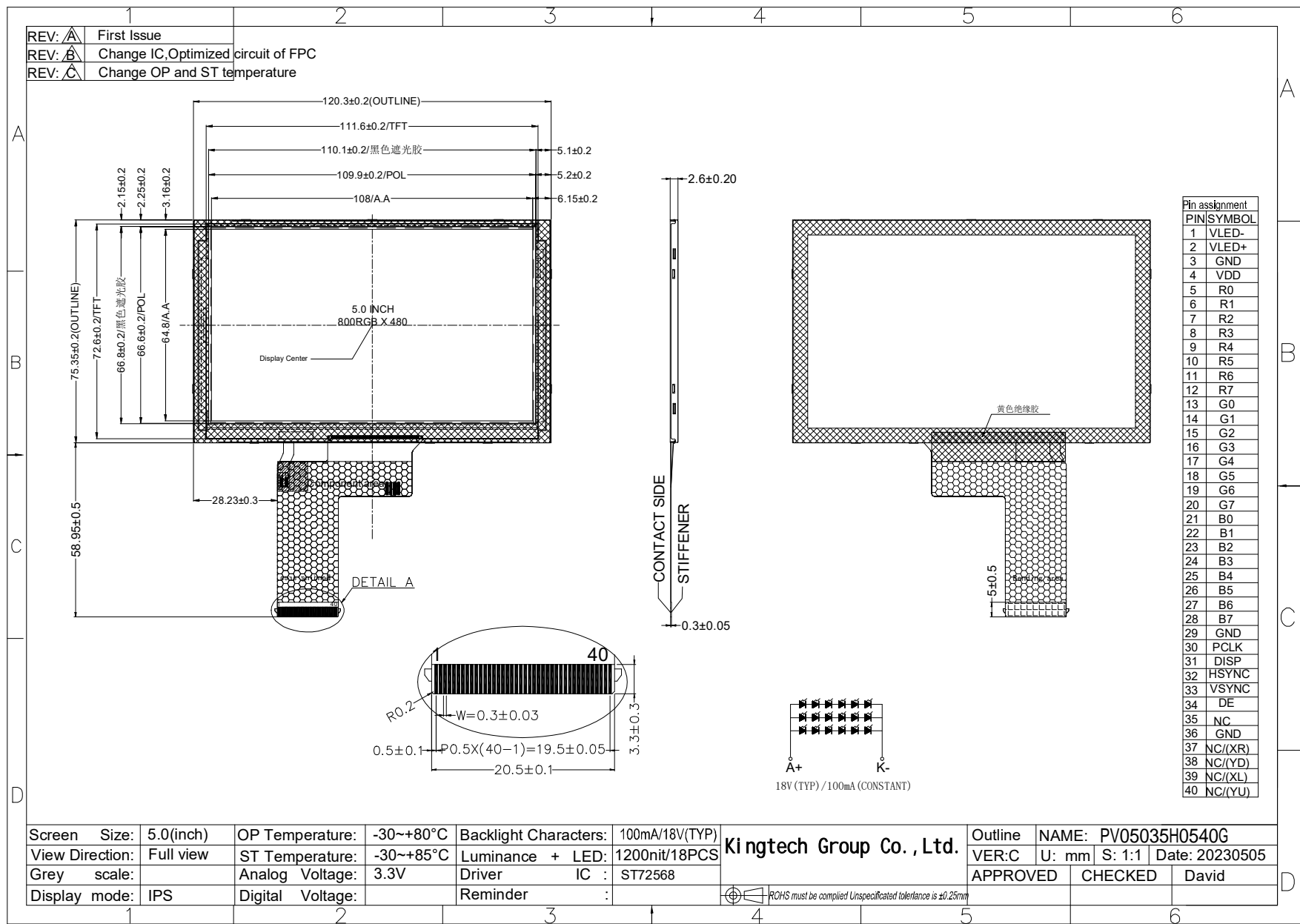



### 4. Absolute Maximum Ratings

The followings are maximum values which, if exceed, may cause faulty operation or damage to the unit. The operational and non-operational maximum voltage and current values are listed in Table.

V<sub>SS</sub>=0V, T<sub>a</sub>=25°C

Item	Symbol	Min.	Max.	Unit
Supply Voltage	VDD	-0.3	4.0	V
	VDDI	-0.3	4.0	V
Storage temperature	T <sub>STG</sub>	<b>-30</b>	<b>+85</b>	°C
Operating temperature	T <sub>OP</sub>	<b>-30</b>	<b>+80</b>	°C

Note 1: If T<sub>a</sub> below 50°C, the maximal humidity is 90%RH, if T<sub>a</sub> over 50°C, absolute humidity should be less than 60%RH.

Note 2: The response time will be extremely slow when the operating temperature is around -10°C, and the back ground will become darker at high temperature operating.

Note 3: These range above is maximum value not the actual operating temperature . Actual Operating temperature is no more than 40°C and temperature refers to the LCM surface temperature ;

Note 4: GWD is not responsible for product problems beyond the use conditions.

Note 5: Temperature and relative humidity range are shown in the figure below. Wet bulb temperature should be 39 °C max. and no condensation of water.

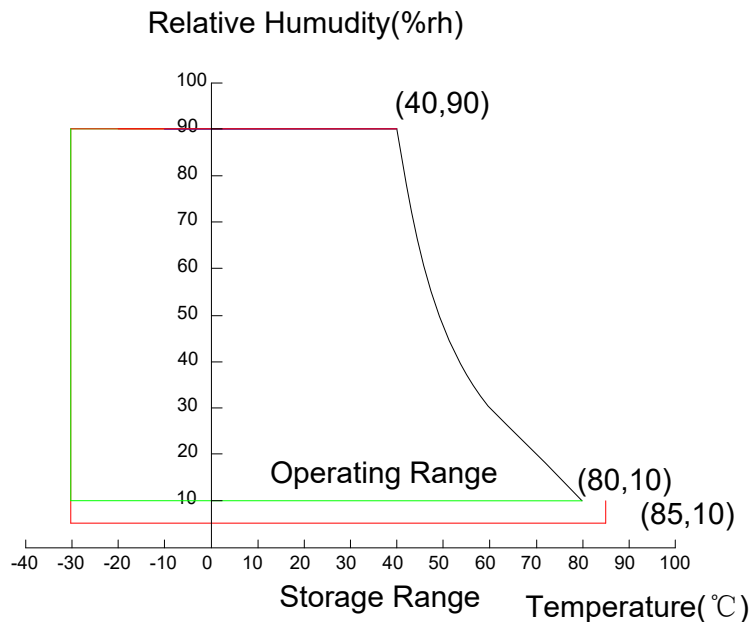



**5. DC Characteristics**

Item	Symbol	Min.	Typ.	Max.	Unit
Supply Voltage	VDD	3.0	3.3	3.6	V
	VDDI	3.0	3.3	3.6	V
	VGH	10	12	14	V
	VGL	-14	-11.5	-11.5	V
Logic Low input voltage	V <sub>IL</sub>	0	-	0.3*VDDI	V
Logic High input voltage	V <sub>IH</sub>	0.7*VDDI	-	VDDI	V
Logic Low output voltage	V <sub>OL</sub>	GND	-	GND+0.4	
Logic High output voltage	V <sub>OH</sub>	VDDI-0.4	-	VDDI	

Note 1: All of the voltage listed above are with respective to GND = 0v

Note 2: Device is subject to be damaged permanently if stresses beyond those absolute maximum rating listed above

**6. Backlight Characteristics**

**6.1. Backlight Characteristics**

Item	Symbol	Condition	Min.	Typ.	Max.	Unit
Backlight Voltage	V <sub>LED</sub>	Ta=25 °C	16	<b>18</b>	19	V
Backlight Current	I <sub>LED</sub>	Ta=25 °C, V <sub>F</sub> =6V/LED	-	<b>100</b>	-	mA
Power dissipation	P <sub>D</sub>		-	<b>1800</b>	-	mW
Uniformity	Avg			75	-	%
LED working life(25°C)	-		20000	30000	-	Hrs
Drive method	Constant current					
LED Configuration	18 White LEDs(6 LEDs in one string and 3 groups in parallel)					

Note1: LED life time defined as follows: The final brightness is at 50% of original brightness.

The environmental conducted under ambient air flow, at Ta=25±2 °C,60%RH±5%, I<sub>F</sub>=20mA/LED.

**6.2. Backlighting circuit**

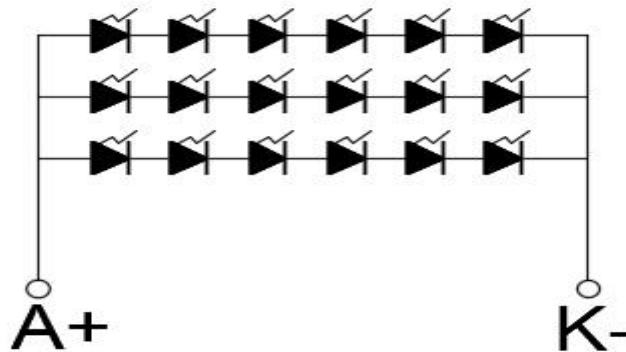



## 7. Optical Characteristics

### 7.1. Optical Characteristics

Ta=25°C, DVDD=3.3V

	Item	Symbol	Condition	Specification			Unit	
				Min.	Typ.	Max.		
Backlight On (Transmissive Mode)	Luminance on TFT	Lv	Normally viewing angle $\theta_x = \phi_y = 0^\circ$	1000	1200	-	cd/m <sup>2</sup>	
	Contrast ratio(See7.3)	CR		700	1000	-		
	Response time (See 7.2)	TR+TF		-	30	40	ms	
	Chromaticity Transmissive (See 7.5)	Red		X <sub>R</sub>	0.575	0.625	0.675	
				Y <sub>R</sub>	0.263	0.313	0.363	
		Green		X <sub>G</sub>	0.262	0.312	0.362	
				Y <sub>G</sub>	0.514	0.564	0.614	
		Blue		X <sub>B</sub>	0.091	0.141	0.191	
				Y <sub>B</sub>	0.093	0.143	0.193	
		White		X <sub>W</sub>	0.288	0.338	0.388	
				Y <sub>W</sub>	0.318	0.368	0.418	
	Viewing Angle (See 7.4)	Horizontal		$\theta_{x+}$	70	80	-	Deg.
				$\theta_{x-}$	70	80	-	
Vertical		$\phi_{y+}$	70	80	-			
		$\phi_{y-}$	70	80	-			

### 7.2. Definition of Response Time

#### 7.2.1. Normally Black Type (Negative)

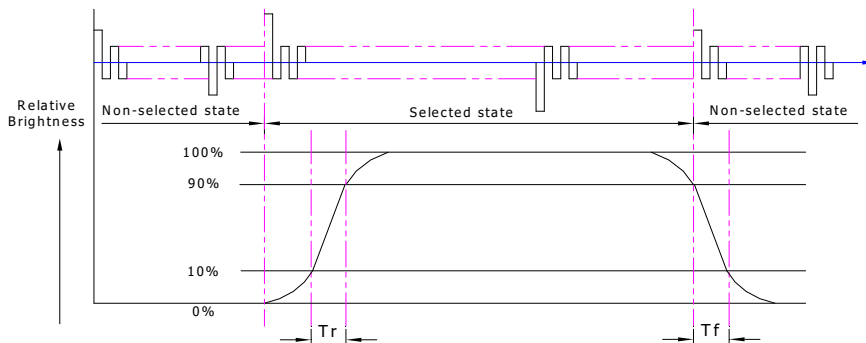

Tr is the time it takes to change from non-selected stage with relative luminance 10% to selected state with relative luminance 90%;

Tf is the time it takes to change from selected state with relative luminance 90% to non-selected state with relative luminance 10%

Note: Measuring machine: LCD-5100



7.2.2. Normally White Type (Positive)

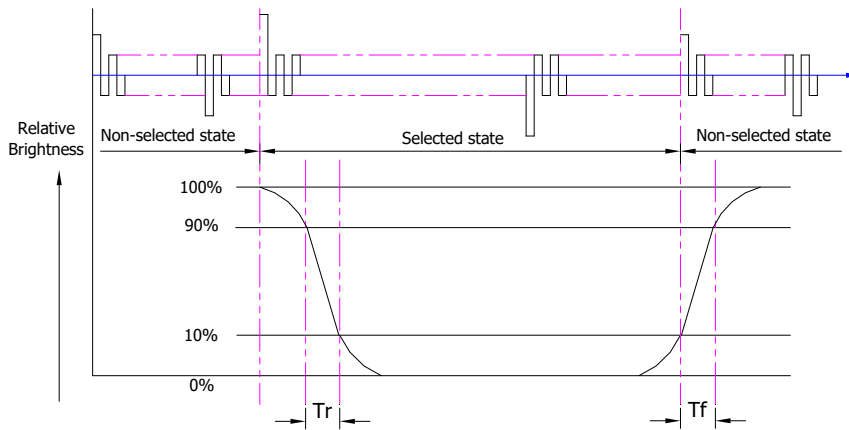

$T_r$  is the time it takes to change from non-selected state with relative luminance 90% to selected state with relative luminance 10%;

$T_f$  is the time it takes to change from selected state with relative luminance 10% to non-selected state with relative luminance 90%;

Note: Measuring machine: LCD-5100 or EQUI

7.3. Definition of Contrast Ratio

Contrast is measured perpendicular to display surface in reflective and transmissive mode. The measurement condition is:

Measuring Equipment	Eldim or Equivalent
Measuring Point Diameter	3mm//1mm
Measuring Point Location	Active Area centre point
Test pattern	A: All Pixels white
	B: All Pixel black
Contrast setting	Maximum

Definitions: CR (Contrast) = Luminance of White Pixel / Luminance of Black Pixel

7.4. Definition of Viewing Angles

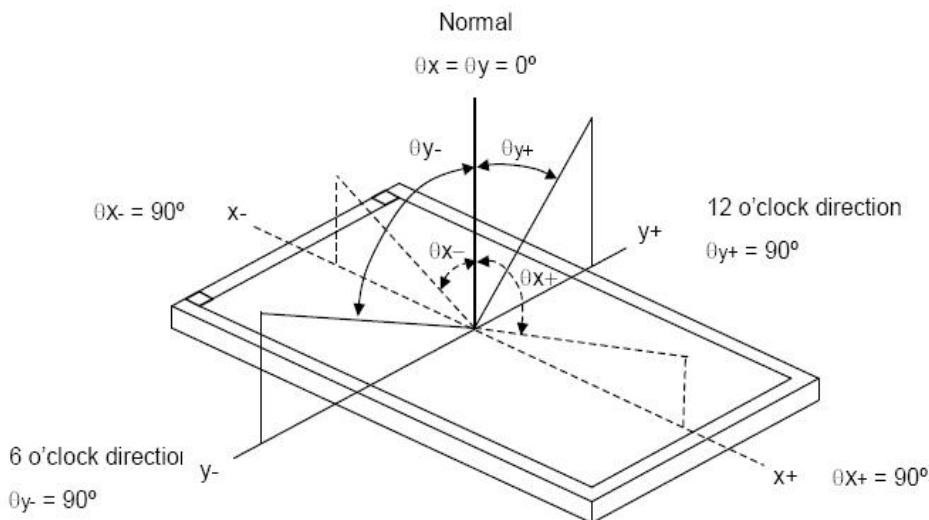

Measuring machine: LCD-5100 or EQUI



**7.5. Definition of Color Appearance**

R,G,B and W are defined by (x, y) on the IE chromaticity diagram

NTSC=area of RGB triangle/area of NTSC triangleX100%

Measuring picture: Red, Green, Blue and White (Measuring machine: BM-7)

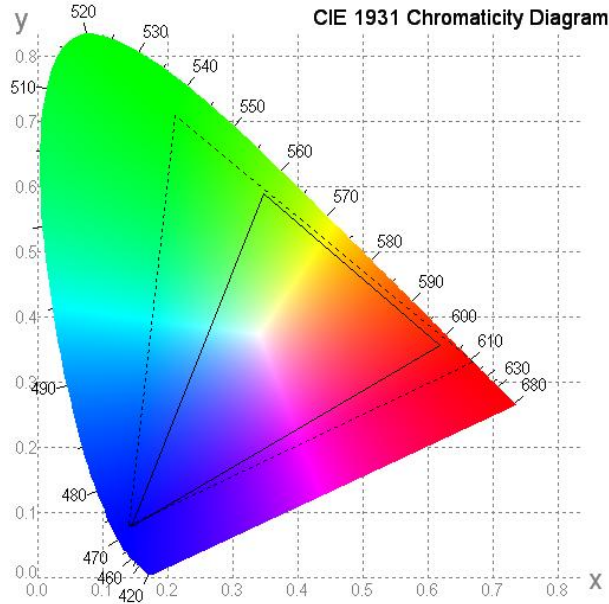

**7.6. Definition of Surface Luminance, Uniformity and Transmittance**

Using the transmissive mode measurement approach, measure the white screen luminance of the display panel and backlight.

7.6.1. Surface Luminance:  $L_V = \text{average} (L_{P1}:L_{P9})$

7.6.2. Uniformity =  $\text{Minimal} (L_{P1}:L_{P9}) / \text{Maximal} (L_{P1}:L_{P9}) * 100\%$

7.6.3. Transmittance =  $L_V \text{ on LCD} / L_V \text{ on Backlight} * 100\%$

Note: Measuring machine: BM-7

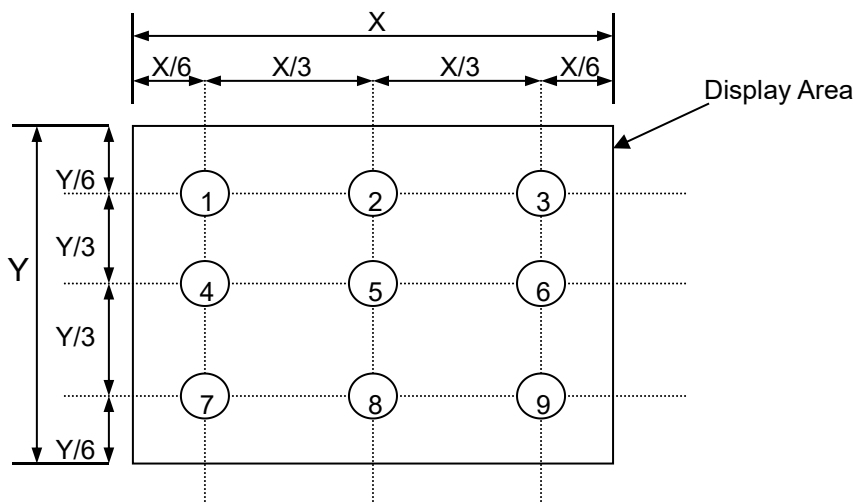



### 8. Block Diagram and Power Supply

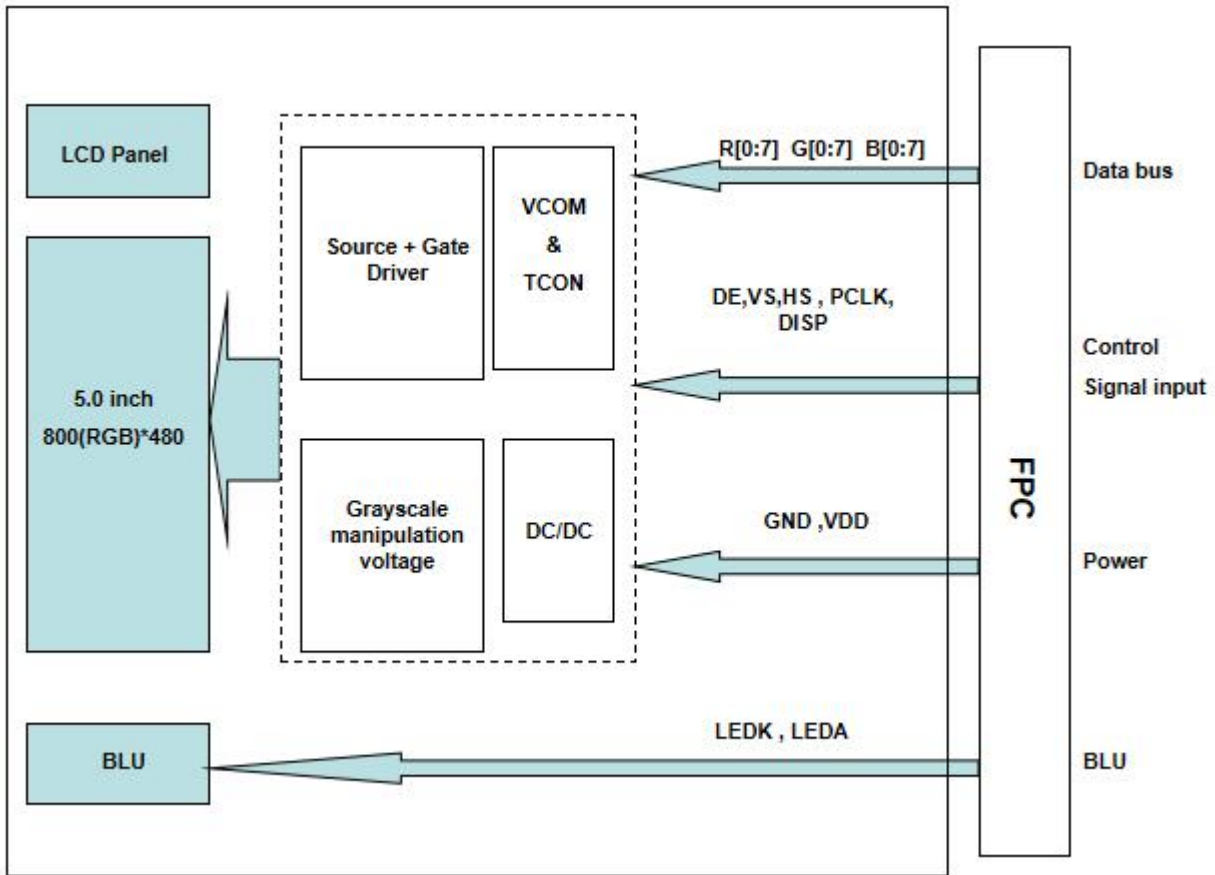



## 9. Interface Pins Definition

No.	Symbol	Function	Remark
1	VLED-	Backlight Cathode	
2	VLED+	Backlight Anode	
3	GND	Ground	
4	VDD	Power source	
5	R0	Red data signal	
6	R1	Red data signal	
7	R2	Red data signal	
8	R3	Red data signal	
9	R4	Red data signal	
10	R5	Red data signal	
11	R6	Red data signal	
12	R7	Red data signal	
13	G0	Green data signal	
14	G1	Green data signal	
15	G2	Green data signal	
16	G3	Green data signal	
17	G4	Green data signal	
18	G5	Green data signal	
19	G6	Green data signal	
20	G7	Green data signal	
21	B0	Blue data signal	
22	B1	Blue data signal	
23	B2	Blue data signal	
24	B3	Blue data signal	
25	B4	Blue data signal	
26	B5	Blue data signal	
27	B6	Blue data signal	
28	B7	Blue data signal	
29	GND	Ground	
30	PCLK	Clock signal to sample each data	
31	DISP	Display on/off signal DISP="H" Display on DISP="L" Display off	
32	Hsync	Horizontal synchronizing signal	
33	Vsync	Vertical synchronizing signal	
34	DE	Input data enable control.	
35	NC	No connection	
36	GND	Ground	
37-40	NC	No connection	



## 10. AC Characteristics

### 10.1.AC Timing characteristics

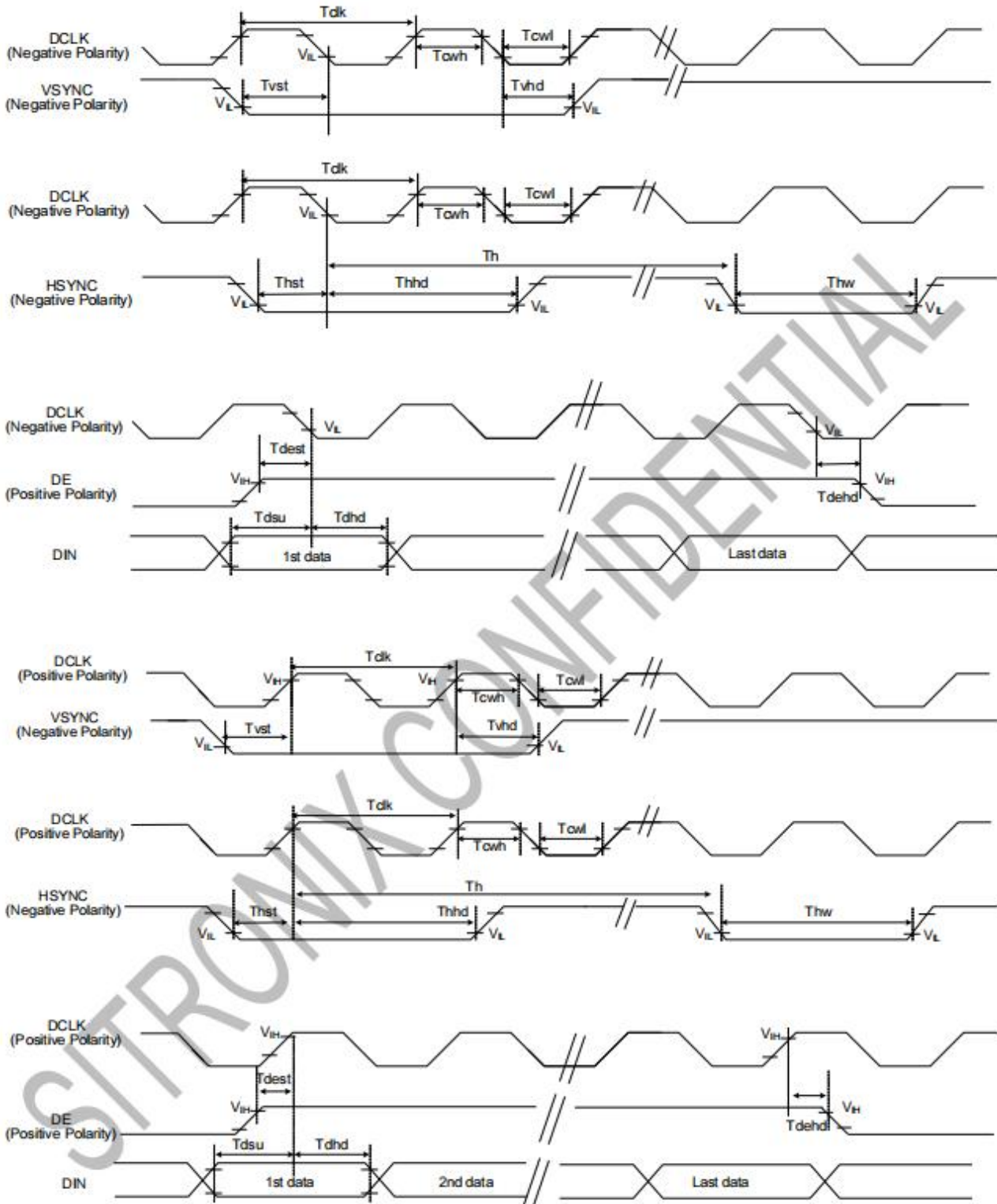



Item	Symbol	Min.	Typ.	Max.	Unit	Conditions
CLK Pulse Duty	Tcw	40	50	60	%	
VSYNC Setup Time	Tvst	10	-	-	ns	
VSYNC Hold Time	Tvhd	10	-	-	ns	
HSYNC Setup Time	Thst	10	-	-	ns	
HSYNC Hold Time	Thhd	10	-	-	ns	
Data Setup Time	Tdsu	10	-	-	ns	
Data Hold Time	Tdhd	10	-	-	ns	
DE Setup Time	Tdest	10	-	-	ns	
DE Hold Time	Tdehd	10	-	-	ns	

## 10.2.Display Timing characteristics

Parallel 24-bit RGB Interface Timing Table							
Item	Symbol	Min.	Typ.	Max.	Unit	Remark	
DCLK Frequency	Fclk	23	25	27	MHz	.	
HSYNC	Period Time	Th	808	816	848	DCLK	
	Display Period	Thdisp	800			DCLK	
	Back Porch	Thbp	4	8	24	DCLK	
	Front Porch	Thfp	4	8	24	DCLK	
	Pulse Width	Thw	2	4	8	DCLK	

VSYNC	Period Time	Tv	496	512	528	HSYNC	
	Display Period	Tvdisp	480			HSYNC	
	Back Porch	Tvbp	8	16	24	HSYNC	
	Front Porch	Tvfp	8	16	24	HSYNC	
	Pulse Width	Tvw	2	4	8	HSYNC	



### 10.3.Power ON/Off Sequence

#### 11.1 Power On Sequence

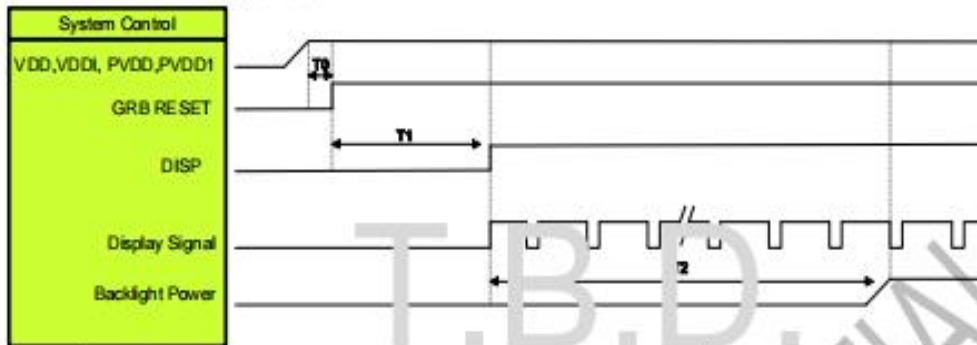

Symbol	Description	Min. Time	Unit
T0	System power stability to GRB RESET signal	0	ms
T1	GRB RESET = "High" to DISP="High"	10	ms
T2	Display Signal output to Backlight Power on	250	ms

Note :

1. When DISP pull "H" or "L", IC will execute the internal power on or power off procedures .Please be careful about the timing of DISP and do not interrupt it during power on or power off procedure, otherwise unexpected errors will occur.
2. RGB interface Display signal: DCLK; VSYNC; HSYNC; DE; DR[7:0]; DG[7:0]; DB[7:0]
- 3: LVDS interface Display signal: DCLK P/N; RX[3:0] P/N

#### 11.2 Power Off Sequence

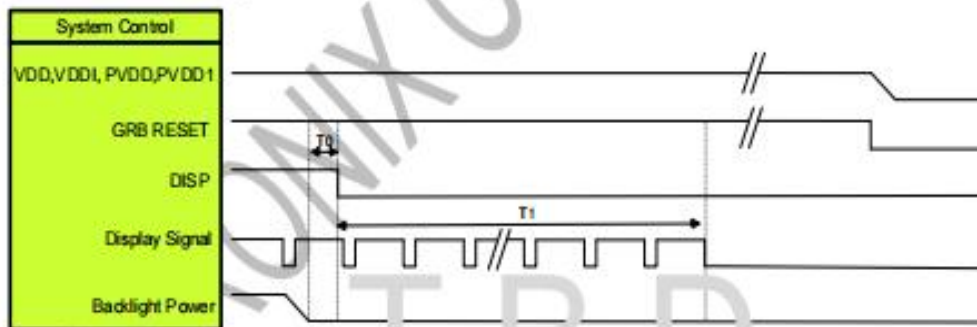

Symbol	Description	Min. Time	Unit
T0	Backlight Power off to DISP="Low"	5	ms
T1	DISP="Low" to IC internal voltage discharge complete	100	ms

Note :

1. When DISP pull "H" or "L", IC will execute the internal power on or power off procedures .Please be careful about the timing of DISP and do not interrupt it during power on or power off procedure, otherwise unexpected errors will occur.
2. RGB interface Display signal: DCLK; VSYNC; HSYNC; DE; DR[7:0]; DG[7:0]; DB[7:0]
- 3: LVDS interface Display signal: DCLK P/N; RX[3:0] P/N



## 11. Quality Assurance

### 11.1. Purpose

This standard for Quality Assurance assures the quality of LCD module products supplied to customer.

### 11.2. Standard for Quality Test

#### 11.2.1. Sampling Plan:

GB2828.1-2012

Single sampling, general inspection level II

#### 11.2.2. Sampling Criteria:

Visual inspection: AQL 1.5

Electrical functional: AQL 0.65.

#### 11.2.3. Reliability Test:

Detailed requirement refer to Reliability Test Specification.

### 11.3. Nonconforming Analysis & Disposition

#### 11.3.1. Nonconforming analysis:

11.3.1.1. Customer should provide overall information of non-conforming sample for their complaints.

11.3.1.2. After receipt of detailed information from customer, the analysis of nonconforming parts usually should be finished in one week.

11.3.1.3. If cannot finish the analysis on time, customer will be notified with the progress status.

#### 11.3.2. Disposition of nonconforming:

11.3.2.1. Non-conforming product over PPM level will be replaced.

11.3.2.2. The cause of non-conformance will be analyzed. Corrective action will be discussed and implemented.

### 11.4. Agreement Items

Shall negotiate with customer if the following situation occurs:

11.4.1. There is any discrepancy in standard of quality assurance.

11.4.2. Additional requirement to be added in product specification.

11.4.3. Any other special problem.

### 11.5. Standard of the Product Visual Inspection

#### 11.5.1. Appearance inspection:

11.5.1.1. The inspection must be under illumination about 1000 – 1500 lx, and the distance of view must be at 30cm ± 2cm.

11.5.1.2. The viewing angle should be 45° from the vertical line without reflection light or follows customer's viewing angle specifications.

11.5.1.3. Definition of area: A Zone: Active Area, B Zone: Viewing Area,

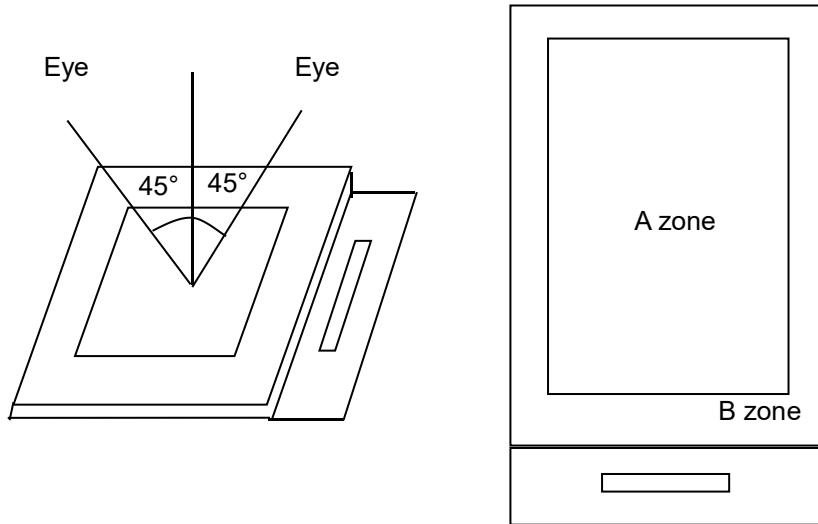

11.5.2. Basic principle:

11.5.2.1. A set of sample to indicate the limit of acceptable quality level must be discussed by both us and customer when there is any dispute happened.

11.5.2.2. New item must be added on time when it is necessary.

**11.6. Inspection Specification**

These inspection standards shall be applied to LCD Module supplied by Kingtech Group Co.,Ltd. This model is only used in CE product, if it is used in other product applications; it still adopts this copy of specification. If there are any other product applications such as handwriting recognition, Industrial use, Medical use, Aerospace usage and so on, the specifications should be negotiated separately.

01 Definition of dot defect induced from the panel inside

- a) Bright dot: Dots appear bright and unchanged in size in which LCD panel is displaying under black pattern.
- b) Dark dot: Dots appear dark and unchanged in size in which LCD panel is displaying under pure red, green, blue picture.
- c) 2 dot adjacent = 1 pair = 2 dots

Picture:





No.	Display Inspection		
	Items	Criteria (Unit: mm)	
02	Bright dot	Random	$N \leq 1$
		2 dots adjacent	$N \leq 0$
		3 dots adjacent	$N \leq 0$
	Dark dot	Random	$N \leq 2$
		2 dots adjacent	$N \leq 0$
		3 dots adjacent	$N \leq 0$
	Total bright dot and dark dot		$N \leq 2$
Distance	Minimum Distance Between dark dots	5mm	
	Minimum Distance Between dark and bright dots		
Tiny bright dot		visible through 6% ND filter $D \leq 0.1\text{mm}$ , Ignore $0.1\text{mm} < D \leq 0.3\text{mm}$ , $N \leq 2$ Distance $\geq 5\text{mm}$	
Display failure (V-line/Cross line etc)		Not allowable	
Mura/Waving/Hot spot	Not visible through 6% ND filter in 50% gray or judge by limit sample if necessary		

\*Note: Defect which is on the Black Matrix (outside of Active Area) are not considered as a defect.

No.	Appearance & Display inspection	
	Items	Criteria (Unit: mm)
03	Foreign Black/White/Bright Spot (Display & Appearance)	$D \leq 0.1\text{mm}$ , Ignore, $0.1\text{mm} < D \leq 0.3\text{mm}$ , $N \leq 2$ Distance $\geq 5\text{mm}$ , It is shown in Fig. 2.
	Foreign Black/White/Bright Line (Display & Appearance)	$W \leq 0.03\text{ mm}$ , Ignore $0.03 < W \leq 0.05\text{ mm}$ $L \leq 3.0\text{ mm}$ , $N \leq 3$ It is shown in Fig. 3.
	Polarizer Dent/Air Bubble	$D \leq 0.1\text{mm}$ , Ignore $0.1\text{mm} < D \leq 0.3\text{mm}$ , $N \leq 2$ Distance $\geq 5\text{mm}$
	Polarizer Scratches	$W \leq 0.03\text{ mm}$ , Ignore $0.03 < W \leq 0.05\text{ mm}$ $L \leq 3.0\text{ mm}$ , $N \leq 3$

Notes: If any specific defect is not included in the above defect table, this defect should be judged by INX/ODM/Brand customer discussion.

- 1. W: Width                      3. D: Average Diameter
- 2. L: Length                    4. N: Count

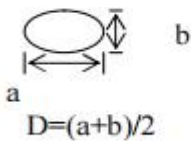

Fig. 2



W: width, L : length

Fig. 3

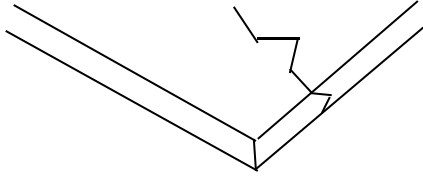
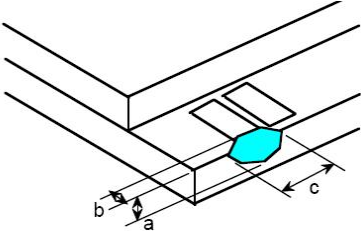
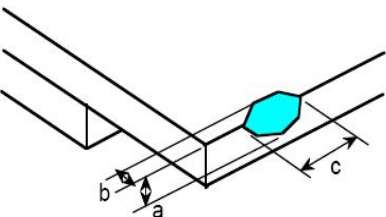
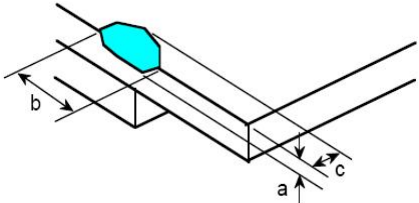

No.	Item	Criteria (Unit: mm)										
04	Glass Crack (Minor defect)	 <p>Crack is potential to enlarge, any type is not allowed.</p>										
05	Glass Chipping Pad Area: (Minor defect)	 <table border="1" data-bbox="858 698 1326 871"> <thead> <tr> <th>Length and Width</th> <th>Acc. Qty</th> </tr> </thead> <tbody> <tr> <td><math>c &gt; 3.0, b &lt; 1.0</math></td> <td>1</td> </tr> <tr> <td><math>c &lt; 3.0, b &lt; 1.0</math></td> <td>3</td> </tr> <tr> <td colspan="2"><math>a &lt; \text{Glass Thickness}</math></td> </tr> </tbody> </table>	Length and Width	Acc. Qty	$c > 3.0, b < 1.0$	1	$c < 3.0, b < 1.0$	3	$a < \text{Glass Thickness}$			
Length and Width	Acc. Qty											
$c > 3.0, b < 1.0$	1											
$c < 3.0, b < 1.0$	3											
$a < \text{Glass Thickness}$												
06	Glass Chipping Rear of Pad Area: (Minor defect)	 <table border="1" data-bbox="858 1088 1326 1301"> <thead> <tr> <th>Length and Width</th> <th>Acc. Qty</th> </tr> </thead> <tbody> <tr> <td><math>c &gt; 3.0, b &lt; 1.0</math></td> <td>1</td> </tr> <tr> <td><math>c &lt; 3.0, b &lt; 1.0</math></td> <td>2</td> </tr> <tr> <td><math>c &lt; 3.0, b &lt; 0.5</math></td> <td>4</td> </tr> <tr> <td colspan="2"><math>a &lt; \text{Glass Thickness}</math></td> </tr> </tbody> </table>	Length and Width	Acc. Qty	$c > 3.0, b < 1.0$	1	$c < 3.0, b < 1.0$	2	$c < 3.0, b < 0.5$	4	$a < \text{Glass Thickness}$	
Length and Width	Acc. Qty											
$c > 3.0, b < 1.0$	1											
$c < 3.0, b < 1.0$	2											
$c < 3.0, b < 0.5$	4											
$a < \text{Glass Thickness}$												
07	Glass Chipping Except Pad Area: (Minor defect)	 <table border="1" data-bbox="858 1460 1326 1673"> <thead> <tr> <th>Length and Width</th> <th>Acc. Qty</th> </tr> </thead> <tbody> <tr> <td><math>c &gt; 3.0, b &lt; 1.0</math></td> <td>1</td> </tr> <tr> <td><math>c &lt; 3.0, b &lt; 1.0</math></td> <td>2</td> </tr> <tr> <td><math>c &lt; 3.0, b &lt; 0.5</math></td> <td>4</td> </tr> <tr> <td colspan="2"><math>a &lt; \text{Glass Thickness}</math></td> </tr> </tbody> </table>	Length and Width	Acc. Qty	$c > 3.0, b < 1.0$	1	$c < 3.0, b < 1.0$	2	$c < 3.0, b < 0.5$	4	$a < \text{Glass Thickness}$	
Length and Width	Acc. Qty											
$c > 3.0, b < 1.0$	1											
$c < 3.0, b < 1.0$	2											
$c < 3.0, b < 0.5$	4											
$a < \text{Glass Thickness}$												

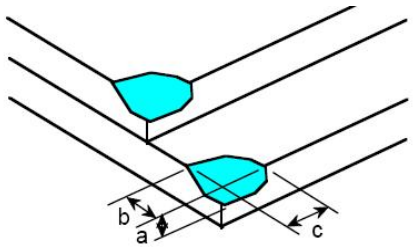
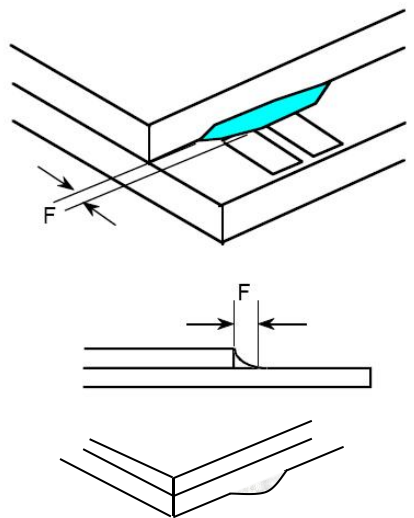
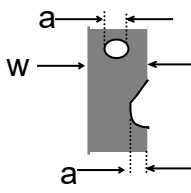

<p>08</p>	<p>Glass Corner Chipping: (Minor defect)</p> 	<table border="1"> <tr> <th>Length and Width</th> <th>Acc. Qty</th> </tr> <tr> <td><math>c &lt; 3.0, b &lt; 3.0</math></td> <td>Ignore</td> </tr> <tr> <td colspan="2"><math>a &lt; \text{Glass Thickness}</math></td> </tr> </table>	Length and Width	Acc. Qty	$c < 3.0, b < 3.0$	Ignore	$a < \text{Glass Thickness}$			
Length and Width	Acc. Qty									
$c < 3.0, b < 3.0$	Ignore									
$a < \text{Glass Thickness}$										
<p>09</p>	<p>Glass Burr: (Minor defect)</p> 	<table border="1"> <tr> <th>Length</th> <th>Acc. Qty</th> </tr> <tr> <td><math>F &lt; 1.0</math></td> <td>Ignore</td> </tr> </table> <p>Glass burr don't affect assemble and module dimension.</p>	Length	Acc. Qty	$F < 1.0$	Ignore				
Length	Acc. Qty									
$F < 1.0$	Ignore									
<p>10</p>	<p>FPC Defect: (Minor defect)</p> 	<p>10.1 Dent, pinhole width <math>a &lt; w/3</math>. (w: circuitry width.) 10.2 Open circuit is unacceptable. 10.3 No oxidation, contamination and distortion.</p>								
<p>11</p>	<p>Bubble on Polarizer (Minor defect)</p>	<table border="1"> <tr> <th>Diameter</th> <th>Acc. Qty</th> </tr> <tr> <td><math>\varphi \leq 0.30</math></td> <td>Ignore</td> </tr> <tr> <td><math>0.30 &lt; \varphi \leq 0.50</math></td> <td><math>N \leq 2</math></td> </tr> <tr> <td><math>0.50 &lt; \varphi</math></td> <td><math>N = 0</math></td> </tr> </table>	Diameter	Acc. Qty	$\varphi \leq 0.30$	Ignore	$0.30 < \varphi \leq 0.50$	$N \leq 2$	$0.50 < \varphi$	$N = 0$
Diameter	Acc. Qty									
$\varphi \leq 0.30$	Ignore									
$0.30 < \varphi \leq 0.50$	$N \leq 2$									
$0.50 < \varphi$	$N = 0$									
<p>12</p>	<p>Dent on Polarizer (Minor defect)</p>	<table border="1"> <tr> <th>Diameter</th> <th>Acc. Qty</th> </tr> <tr> <td><math>\varphi \leq 0.25</math></td> <td>Ignore</td> </tr> <tr> <td><math>0.25 &lt; \varphi \leq 0.50</math></td> <td><math>N \leq 4</math></td> </tr> <tr> <td><math>0.50 &lt; \varphi</math></td> <td>None</td> </tr> </table>	Diameter	Acc. Qty	$\varphi \leq 0.25$	Ignore	$0.25 < \varphi \leq 0.50$	$N \leq 4$	$0.50 < \varphi$	None
Diameter	Acc. Qty									
$\varphi \leq 0.25$	Ignore									
$0.25 < \varphi \leq 0.50$	$N \leq 4$									
$0.50 < \varphi$	None									



13	Bezel	13.1 No rust, distortion on the Bezel. 13.2 No visible fingerprints, stains or other contamination.
14	Touch Panel	D: Diameter    W: width    L: length 14.1 Spot: $D < 0.25$ is acceptable $0.25 \leq D \leq 0.4$ 2dots are acceptable and the distance between defects should more than 10 mm. $D > 0.4$ is unacceptable 14.2 Dent: $D > 0.40$ is unacceptable 14.3 Scratch: $W \leq 0.03$ , $L \leq 10$ is acceptable, $0.03 < W \leq 0.10$ , $L \leq 10$ is acceptable Distance between 2 defects should more than 10 mm. $W > 0.10$ is unacceptable.
15	PCB	15.1 No distortion or contamination on PCB terminals. 15.2 All components on PCB must same as documented on the BOM/component layout. 15.3 Follow IPC-A-600F.
16	Soldering	Follow IPC-A-610C standard
17	Electrical Defect (Major defect)	The below defects must be rejected. 17.1 Missing vertical / horizontal segment, 17.2 Abnormal Display. 17.3 No function or no display. 17.4 Current exceeds product specifications. 17.5 LCD viewing angle defect. 17.6 No Backlight. 17.7 Dark Backlight. 17.8 Touch Panel no function.

Remark: LCD Panel Broken shall be rejected. Defect out of LCD viewing area is acceptable.

**11.7. Classification of Defects**

- 11.7.1. Visual defects (Except no / wrong label) are treated as minor defect and electrical defect is major.
- 11.7.2. Two minor defects are equal to one major in lot sampling inspection.

**11.8. Identification/marketing criteria**

Any unit with illegible / wrong /double or no marking/ label shall be rejected.



**11.9.Packing**

- 11.9.1. There should be no damage of the outside carton box, each packaging box should have one identical label.
- 11.9.2. Modules inside package box should have compliant mark.
- 11.9.3. All direct package materials shall offer ESD protection.

**Note1:** Bright dot is defined as the defective area of the dot is larger than 50% of one sub-pixel area.

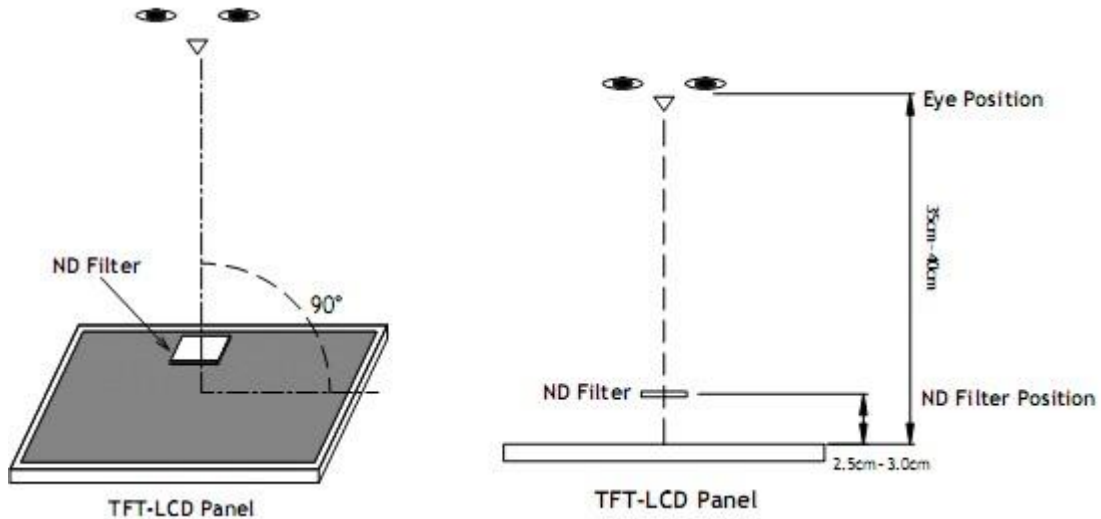

**Bright dot:** The bright dot size defect at black display pattern. It can be recognized by 2% transparency of filter when the distance between eyes and panel is  $350\text{mm} \pm 50\text{mm}$ .

**Dark dot:** Cyan, Magenta or Yellow dot size defect at white display pattern. It can be recognized by 5% transparency of filter when the distance between eyes and panel is  $350\text{mm} \pm 50\text{mm}$ .

**Note2:** Mura on display which appears darker / brighter against background brightness on parts of display area.



**12. Reliability Specification**

No	Item	Condition	Quantity	Criteria
1	High Temperature Operating	80°C, 120Hrs	2	GB/T2423.2-2008
2	Low Temperature Operating	-30°C, 120Hrs	2	GB/T2423.1-2008
3	High Humidity	<b>60°C, 90%RH, 120Hrs</b>	2	GB/T2423.3-2016
4	High Temperature Storage	85°C, 120Hrs	2	GB/T2423.2-2008
5	Low Temperature Storage	-30°C, 120Hrs	2	GB/T2423.1-2008
6	Thermal Cycling Test	-30°C, 60min~80°C, 60min, 20 cycles.	2	GB/T2423.22-2012
7	Packing vibration	Frequency range:10Hz~50Hz Acceleration of gravity:5G X, Y, Z 30 min for each direction.	2	GB/T5170.14-2009
8	Electrical Static Discharge	Air: ±8KV 150pF/330 Ω 5 times	2	GB/T17626.2-2018
		Contact: ±4KV 150pF/330 Ω 5 times		
9	Drop Test (Packaged)	Height:80 cm, 1 corner, 3 edges, 6 surfaces.	2	GB/T2423.8-1995

Note1. No deflection cosmetic and operational function allowable.

Note2. Total current Consumption should be below double of initial value



## 13. Precautions and Warranty

### 13.1. Safety

- 13.1.1. The liquid crystal in the LCD is poisonous. Do not put it in your mouth. If the liquid crystal touches your skin or clothes, wash it off immediately using soap and water.
- 13.1.2. Since the liquid crystal cells are made of glass, do not apply strong impact on them. Handle with care.

### 13.2. Handling

- 13.2.1. Reverse and use within ratings in order to keep performance and prevent damage.
- 13.2.2. Do not wipe the polarizer with dry cloth, as it might cause scratch. If the surface of the LCD needs to be cleaned, wipe it swiftly with cotton or other soft cloth soaked with petroleum IPA, do not use other chemicals.

### 13.3. Storage

- 13.3.1. Do not store the LCD module beyond the specified temperature ranges.
- 13.3.2. Strong light exposure causes degradation of polarizer and color filter.

### 13.4. Metal Pin (Apply to Products with Metal Pins)

#### 13.4.1. Pins of LCD and Backlight

- 13.4.1.1. Solder tip can touch and press on the tip of Pin LEAD during the soldering

#### 13.4.1.2. Recommended Soldering Conditions

Solder Type: Sn96.3~94-Ag3.3~4.3-Cu0.4~1.1

Maximum Solder Temperature: 370°C

Maximum Solder Time: 3s at the maximum temperature

Recommended Soldering Temp: 350±20°C

Typical Soldering Time: ≤3s

#### 13.4.1.3. Solder Wetting

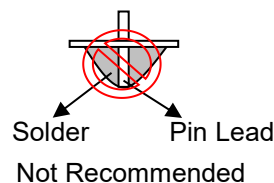
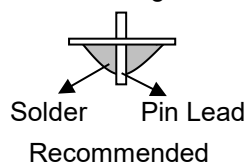

#### 13.4.2. Pins of EL

- 13.4.2.1. Solder tip can touch and press on the tip of EL leads during soldering.

- 13.4.2.2. No Solder Paste on the soldering pad on the motherboard is recommended.

#### 13.4.2.3. Recommended Soldering Conditions

Solder type: Nippon Alimit Leadfree SR-34, size 0.5mm

Recommended Solder Temperature: 270~290°C

Typical Soldering Time: ≤2s

Minimum solder distance from EL lamp (body): 2.0mm

- 13.4.2.4. No horizontal press on the EL leads during soldering.

- 13.4.2.5. 180° bend EL leads three times is not allowed.



13.4.2.6. Solder Wetting

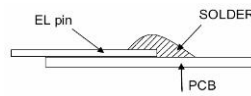

Recommended

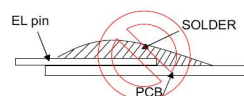

Not Recommended

13.4.2.7. The type of the solder iron:

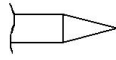

Recommended

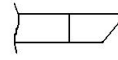

Not Recommended

13.4.2.8. Solder Pad

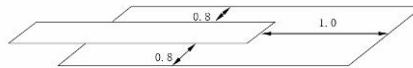

**13.5.Operation**

- 13.5.1. Do not drive LCD with DC voltage
- 13.5.2. Response time will increase below lower temperature
- 13.5.3. Display may change color with different temperature
- 13.5.4. Mechanical disturbance during operation, such as pressing on the display area, may cause the segments to appear “fractured”.
- 13.5.5. Do not connect or disconnect the LCM to or from the system when power is on.
- 13.5.6. Never use the LCM under abnormal condition of high temperature and high humidity.
- 13.5.7. Module has high frequency circuits. Sufficient suppression to the electromagnetic interface shall be done by system manufacturers. Grounding and shielding methods may be important to minimize the interference.
- 13.5.8. Do not display the fixed pattern for long time (we suggest the time not longer than half of one hour) because it may develop image sticking due to the TFT structure.

**13.6.Static Electricity**

- 13.6.1. CMOS LSIs are equipped in this unit, so care must be taken to avoid the electro-static charge, by ground human body, etc.
- 13.6.2. The normal static prevention measures should be observed for work clothes and benches.
- 13.6.3. The module should be kept into anti-static bags or other containers resistant to static for storage.

**13.7.Limited Warranty**

- 13.7.1. Our warranty liability is limited to repair and/or replacement. We will not be responsible for any consequential loss.
- 13.7.2. If possible, we suggest customer to use up all modules in six months. If the module storage time over twelve months, we suggest that recheck it before the module be used.
- 13.7.3. After the product shipped, any product quality issues must be feedback within three months, otherwise, we will not be responsible for the subsequent or consequential events.



## 14. Packaging

TBD