





■ Preliminary Specification

□ Final Specification

SPECIFICATION

Product Model: PV05030Y0140B

DESIGNED	CHECKED	Approved
		

For Customer's Acceptance:

Comments:	Approved by:
-----------	--------------



Table of Contents

	Cover	1
	Revision Record	2
	Table of Contents	3
1	Scope	4
2	General Information	4
3	External Dimensions	5
4	Interface Description	6
5	Absolute Maximum Ratings	7
6	DC Characteristics	7
7	Timing Characteristics	7
8	Backlight Characteristics	10
9	Optical Characteristics	10
10	Reliability Test Conditions and Methods	12
11	Inspection Standard	13
12	Handling Precautions	20
13	Precaution for Use	21
14	Packing Method	21



1. Scope

This specification defines general provisions as well as inspection standards for TFT module supplied by KINGTECH.

2. General Information

TITEM	STANDARD VALUES	UNITS
LCD type	5.0" TFT	--
Dot arrangement	800(RGB)×480	dots
Color filter array	RGB vertical stripe	--
Display mode	Normally BLACK	-
Gray Scale Inversion Direction	ALL o'clock	--
Eyes Viewing Direction	80/80/80/80	
Module size	120.7(W)×75.8(H)×3.0(T)	mm
Active area	108 (W)×64.8(H)	mm
Dot pitch	135(W)×135(H)	um
Interface	RGB 24bit	--
Operating temperature	-20 ~ +70	°C
Storage temperature	-30 ~ +80	°C
Back Light	24White LED	--
Weight	TBD	g



3. External Dimensions

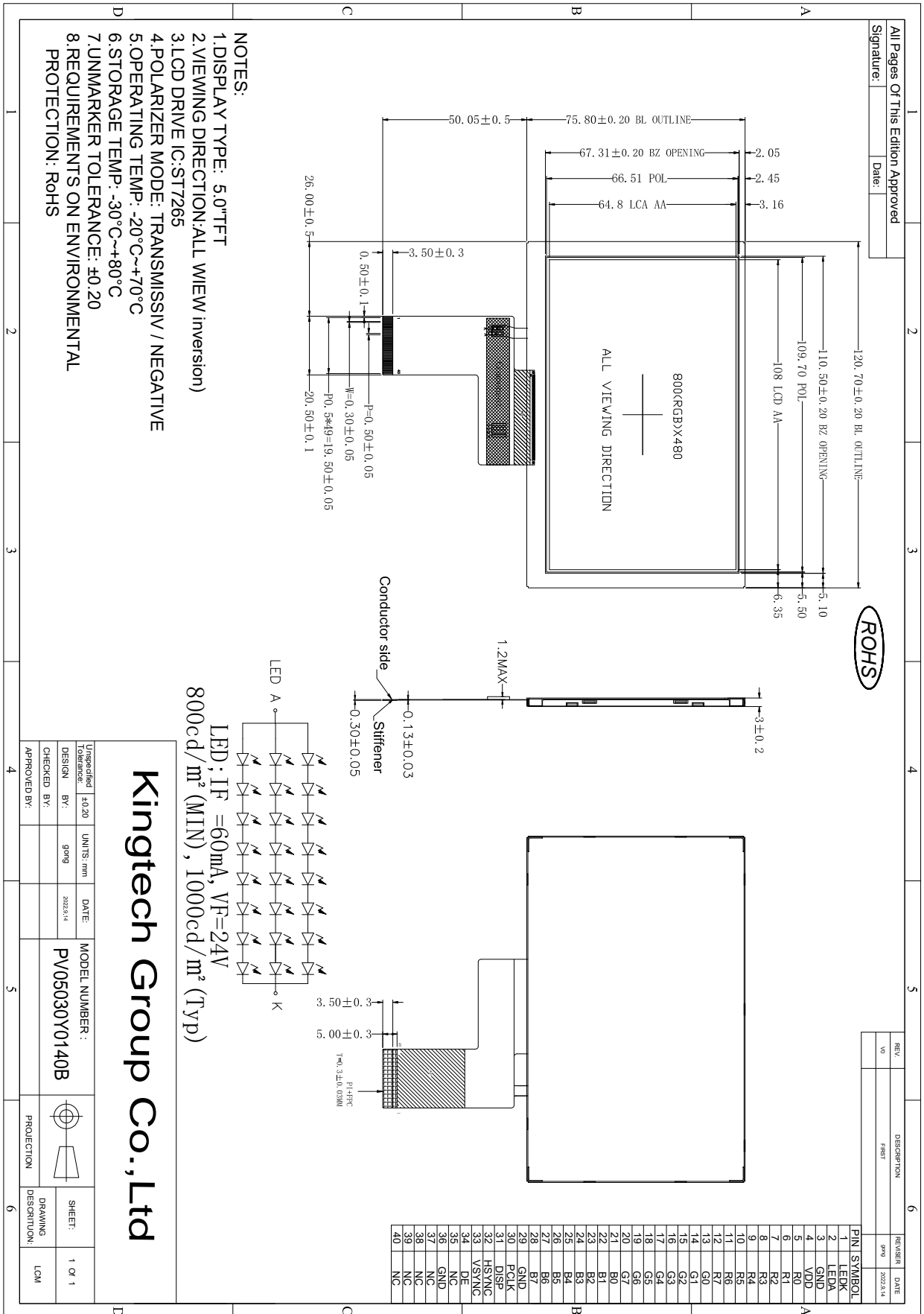



4. Interface Description

PIN NO.	PIN NAME	DESCRIPTION
1	LEDK	LED backlight (Cathode).
2	LEDA	LED backlight (Anode).
3	GND	Ground.
4	VDD	Power supply.
5~12	R0~R7	Red Data
13~20	G0~G7	Green Data
21~28	B0~B7	Blue Data
29	GND	Ground.
30	PCLK	Clock
31	DISP	Display on/off
32	HSYNC	Horizontal sync input in RGB mode.
33	VSYNC	Vertical sync input in RGB mode.
34	DE	Data enable input. Active high to enable the input data bus.
35	NC	No connection
36	GND	Ground.
37	NC	NC
38	NC	NC
39	NC	NC
40	NC	NC



5. Absolute Maximum Ratings

Item	Symbol	Min.	Max.	Unit
Logic Supply Voltage	VCC	-0.5	5	V
Operating Temperature	T _{OP}	-20	70	°C
Storage Temperature	T _{ST}	-30	80	°C

6. Operating Conditions

Item	Symbol	Min.	Typ.	Max.	Unit	Remark
Power Voltage	VCC	3.0	3.3	3.6	V	
Input logic high voltage	V _{IH}	0.7*VCC	-	VCC	V	
Input logic low voltage	V _{IL}	GND	-	0.3*VCC	V	
Current for Power	I _{CC}	-	210	350	mA	VCC=3.3V

7. Timing Characteristics

7.1 DC Characteristics

Item	Symbol	Min.	Typ.	Max.	Unit	Conditions
Logic-High Input Voltage	V _{Ih}	0.7VDDI	-	VDDI	V	
Logic-Low Input Voltage	V _{Il}	DGND	-	0.3VDDI	V	
Logic-High Output Voltage	V _{oh}	VDDI-0.4	-	VDDI	V	
Logic-Low Output Voltage	V _{ol}	DGND	-	DGND+0.4	V	

Item	Symbol	Min.	Typ.	Max.	Unit	Conditions
Positive High-Voltage Power	V _{GHS}	9	15	17	V	No Load@ FR=60Hz
Negative High-Voltage Power	V _{GL}	-11.5	-10.5	-7	V	
Output Voltage Deviation	V _{od}	-	±40	±50	mV	
Standby Current	I _{sc}	-	-	50	uA	
Operation Current	I _{oc}	-	40	-	mA	



7.2 AC Characteristics

Item	Symbol	Min.	Typ.	Max.	Unit	Conditions
VDD Power Source Slew Time	TPOR	-	-	20	ms	From 0V to 99% VDD
GRB Pulse Width	tRSTW	10	50	-	us	R=10Kohm, C=1uF
SD Output Stable Time	Tst	-	-	12	us	Output settled within +20mV Loading = 6.8k+28.2pF.
GD Output Rise and Fall Time	Tgst	-	-	6	us	Output settled (5%~95%), Loading = 4.7k+29.8pF

7.3 Data Timing

Parallel 24-bit RGB Interface Timing Table						
Item	Symbol	Min.	Typ.	Max.	Unit	Remark
DCLK Frequency	Fclk	23	25	27	MHz	
HSYNC	Period Time	Th	808	816	848	DCLK
	Display Period	Thdisp	800			DCLK
	Back Porch	Thbp	4	8	24	DCLK
	Front Porch	Thfp	4	8	24	DCLK
	Pulse Width	Thw	2	4	8	DCLK
VSYNC	Period Time	Tv	496	512	528	HSYNC
	Display Period	Tvdisp	480			HSYNC
	Back Porch	Tvbp	8	16	24	HSYNC
	Front Porch	Tvfp	8	16	24	HSYNC
	Pulse Width	Tvw	2	4	8	HSYNC

Note: Frame rate is 60 ± 5 Hz



7.4 Data Input Format

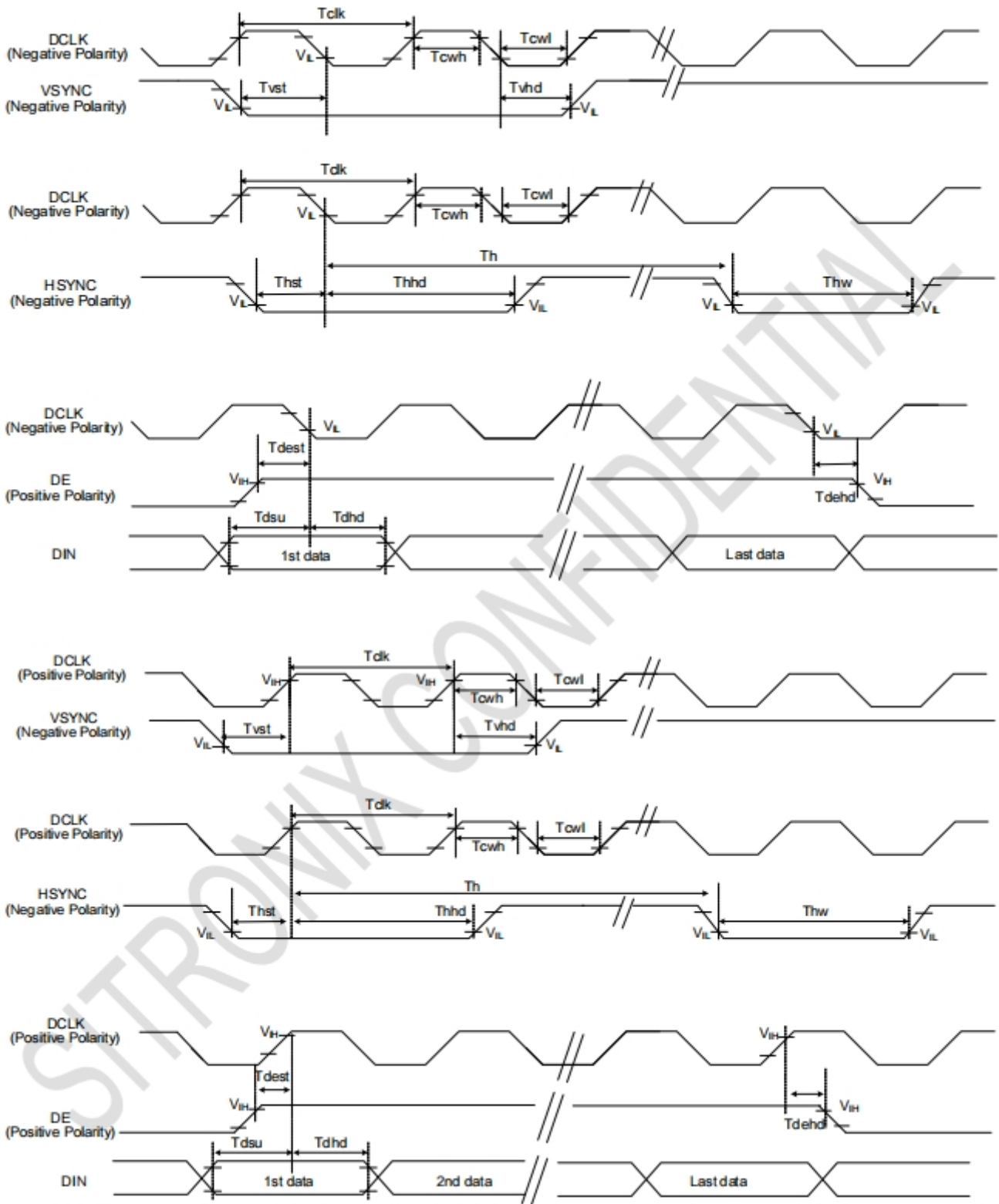



8. Backlight Characteristics

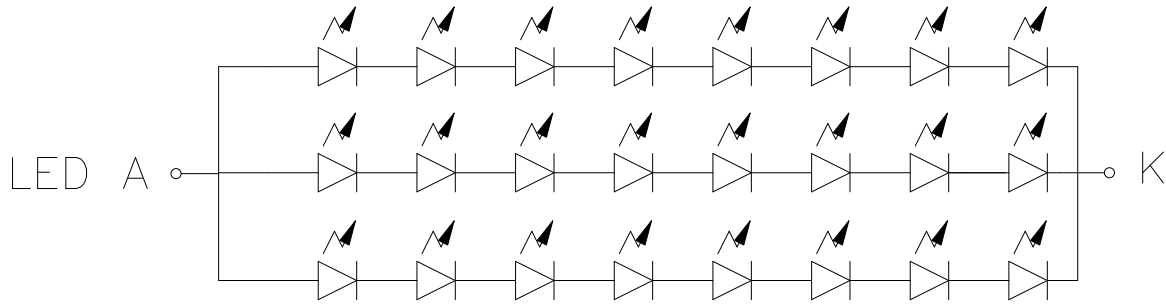

Item	Symbol	MIN	TYP	MAX	UNIT	Test Condition
Supply Voltage	Vf	21.6	24	28.8	V	If=60mA
Supply Current	If	-	60	-	mA	-
Luminous Intensity for LCM	-	800	1000	-	cd/m ²	If=60mA
Uniformity for LCM	-	80	-	-	%	If=60mA
Life Time	-	50000	-	-	Hr	If=60mA
Backlight Color	White					



9. Optical Characteristics

Item	Conditions	Min.	Typ.	Max.	Unit	Note	
Viewing Angle (CR>10)	Horizontal	θ_L	70	80	-	degree	(1),(2),(6)
		θ_R	70	80	-		
	Vertical	θ_T	70	80	-		
		θ_B	70	80	-		
Contrast Ratio	Center	700	1000	-	-	(1),(3),(6)	
Response Time	Rising	-	5	10	ms	(1),(4),(6)	
	Falling	-	15	20			
CF Color Chromaticity (CIE1931)	Red x	Typ. -0.05	TBD	Typ. +0.05	-	(1), (6)	
	Red y		TBD		-		
	Green x		TBD		-		
	Green y		TBD		-		
	Blue x		TBD		-		
	Blue y		TBD		-		
	White x		0.295		-		
	White y		0.290		-		

Note (1) Measurement Setup: The LCD module should be stabilized at given temp. 25°C for 15 minutes to avoid abrupt temperature change during measuring. In order to stabilize the luminance, the measurement should be executed after lighting backlight for 15 minutes in a windless room.

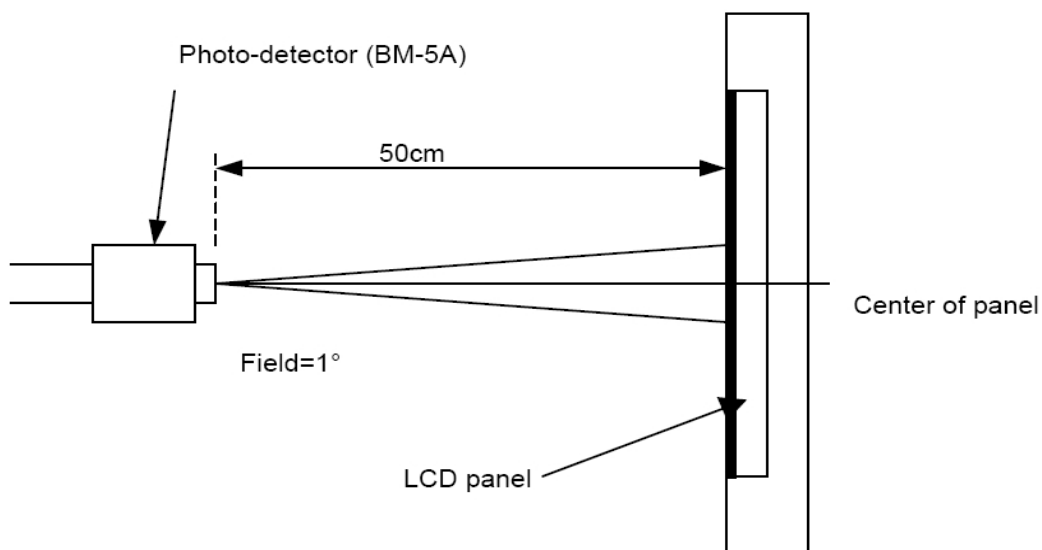



Note (2) Definition of Viewing Angle

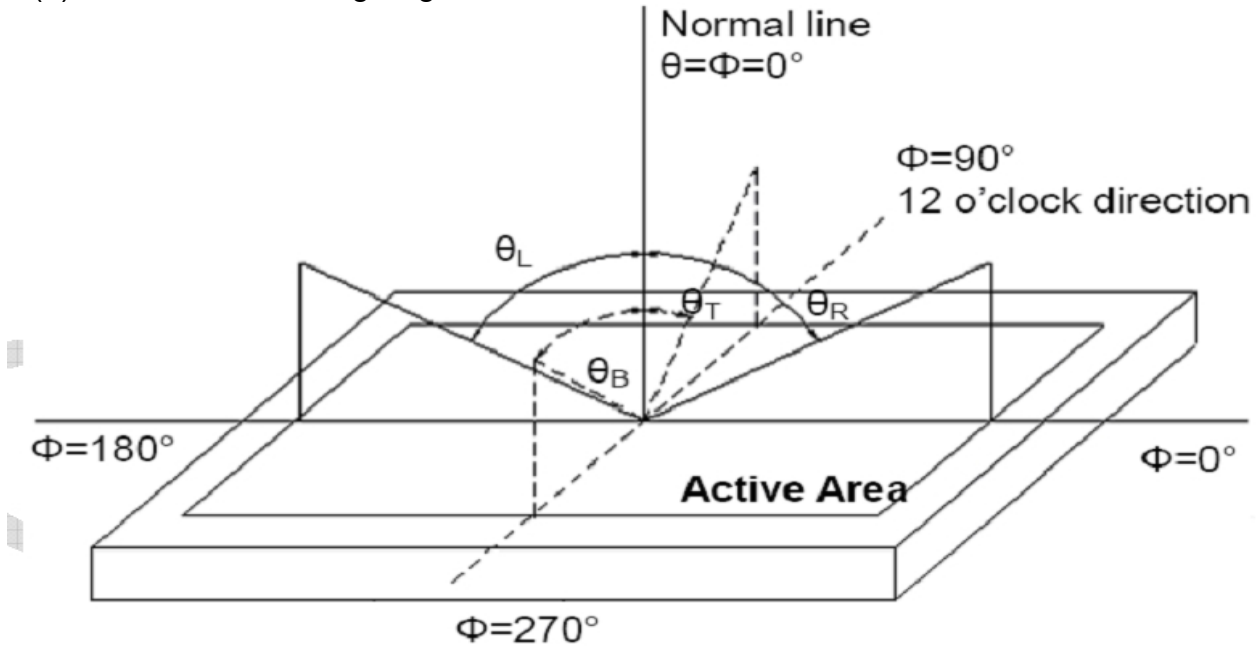

Note (3) Definition of Contrast Ratio (CR)

The contrast ratio can be calculated by the following expression

$$\text{Contrast Ratio (CR)} = L63 / L0$$

L63: Luminance of gray level 63, L0: Luminance of gray level 0

Note (4) Definition of response time

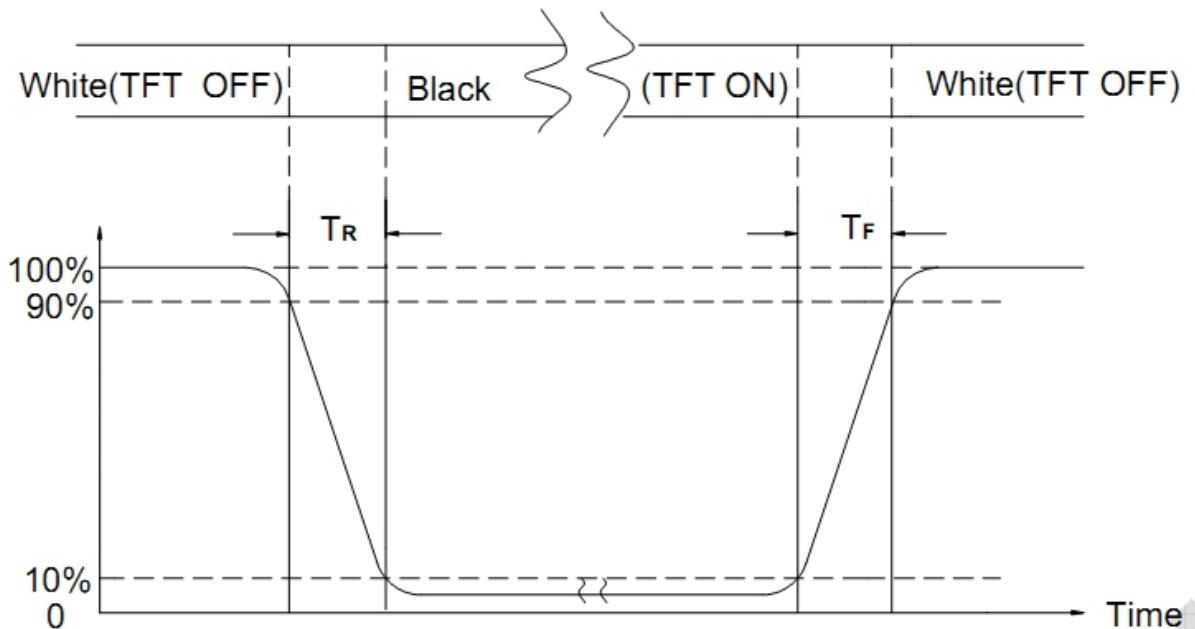

Note (5) Definition of Transmittance (Module is without signal input)

$$\text{Transmittance} = \text{Center Luminance of LCD} / \text{Center Luminance of Back Light} \times 100\%$$

Note (6) Definition of color chromaticity (CIE1931)

Color coordinates measured at the center point of LCD

Note (7) Transmittance is the Value with WV Polarizer and BLU



10. Reliability Test Conditions and Methods

LCM

NO.	TEST ITEMS	TEST CONDITIONS	INSPECTION AFTER TEST
①	High Temperature Storage	80°C±2°C×72Hours	Inspection after 2~4hours storage at room temperature, the samples should be free from defects: <ol style="list-style-type: none"> 1. Air bubble in the LCD. 2. Seal leak. 3. Non-display. 4. Missing segments. 5. Glass crack. 6. Current IDD is twice higher than initial value. 7. The surface shall be free from damage. 8. The electric characteristic requirements shall be satisfied.
②	Low Temperature Storage	-30°C±2°C×72Hours	
③	High Temperature Operating	70°C±2°C×72Hours	
④	Low Temperature Operating	-20°C±2°C×72Hours	
⑤	Temperature Cycle (Storage)	$ \begin{array}{c} -20^{\circ}\text{C} \begin{array}{c} \leftarrow \rightleftarrows \rightarrow \end{array} 25^{\circ}\text{C} \begin{array}{c} \leftarrow \rightleftarrows \rightarrow \end{array} 70^{\circ}\text{C} \\ (30\text{min.}) \quad (5\text{min.}) \quad (30\text{min.}) \\ \leftarrow \quad \quad \quad \rightarrow \\ \text{1cycle} \\ \text{Total 10cycle} \end{array} $	
⑥	Damp Proof Test (Storage)	50°C±5°C×90%RH×72Hours	
⑦	Vibration Test	Frequency:10Hz~55Hz~10Hz Amplitude:1.5MM X, Y, Z direction for total 3hours (Packing condition test will be tested by a carton)	
⑧	Drooping Test	Drop to the ground from 1M height one time every side of carton. (Packing condition test will be tested by a carton)	
⑨	ESD Test	Voltage: ±8KV, R:330Ω, C:150PF, Air Mode,10times	

REMARKS:

1. The Test samples should be applied to only one test item.
2. Sample side for each test item is 5~10pcs.
3. For Damp Proof Test, Pure water (Resistance > 10MΩ) should be used.
4. In case of malfunction defect caused by ESD damage, if it would be recovered to normal state after resetting, it would be judged as a good part.
5. EL evaluation should be accepted from reliability test with humidity and temperature: Some defects such as black spot/blemish can happen by natural chemical reaction with humidity and Fluorescence EL has.
6. Failure Judgment Criterion: Basic Specification Electrical Characteristic, Mechanical Characteristic, Optical Characteristic.



11. Inspection Standards

11.1. Quality

The quality of goods supplied to purchaser shall come up to the following standards:

11.1.1. Inspection Tools and Instruments

Vernier calipers, film scales, multimeter, magnifying eyepiece, ND5%, luminance meter and so on.

11.1.2. The Method of Preserving Goods

After delivery of goods from KINGTECH to purchaser, purchaser shall keep the LCM at -10°C to 30°C, and it might be desirable to keep at the normal room temperature and humidity until incoming inspection or throwing into process line.

11.1.3. Incoming Inspection

(A) The methods of Inspection

If purchaser makes an incoming inspection, a sampling plan shall be applied on the condition that quality of one delivery shall be regarded as one lot.

(B) The standard of quality:

ISO-2859-1 (same as MIL-STD-105E), Level: II

CLASS	AQL (%)
Critical	0.4 %
Major	0.65 %
Minor	1.5 %

Every item shall be inspected according to the class.

(C) Measure

If as the result of above receiving inspection, a lot out is discovered, purchaser Shall inform seller of it within seven days. But first shipment within fourteen days.

11.1.4. Warranty Policy

KINGTECH will provide one-year warranty for the products only if under Specification operating conditions. KINGTECH will replace new products for these defect products which are under warranty period and belong to the responsibility of KINGTECH.

11.2. Checking Condition

11.2.1 Checking direction shall be in the 45 degree area to face the sample.

11.2.2 Inspector shall see from over 300±25mm with bare eyes far from the sample.

11.2.3 Ambient Illumination:

0 ~30 Lux for functional inspection

500 ~ 1200 Lux for external appearance inspection.



11.2.4 Test Area:

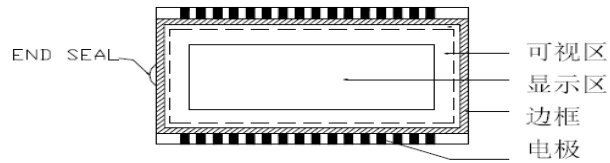

11.2.5 Inspection should be carried out with rope electrostatic ring and static finger cover (both hands except small fingers must be worn)

11.2.6 The inspector may make a visual inspection or a comparative examination with a film ruler and a magnifying eyepiece. Individual defects shall be determined according to the limited samples.

11.2.7 Functional testing uses electrical testing fixtures or test fixtures required by customers.

11.2.8 The ion fan should be used when testing.

11.2.9 The principle of judgement:

11.2.9.1 If the defect outside the visual area does not affect the assembly and display, it will be judged as a good product.

11.2.9.2 **Poor definition:**
Pixel:
 A combination of three sub-pixels (Red + Green + Blue).



Dot:
 Any of the sub-pixels (Red or Green or Blue).

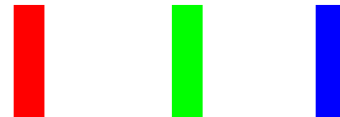

Bright and dark dots:
 A point pixel (sub-pixel: R, G, B pixels) is lit or turned off during the display function test.

Highlights:
 Usually considered to be shown on a black screen.

Dark spots:
 They are generally considered to be shown on R, G, B solid colors or white images.

Neighborhood:
 Two or three adjacent point pixels (dot: sub-pixel) connected together (R, G or G, B or B, R or RGB).



11.3 / 11.4 / 11.5 Inspection Plans:

CLASS	ITEM	JUDGEMENT	CLASS
PACKING & INDICATE	1. OUTSIDE AND INSIDE PACKAGE	"MODEL NO." , "LOT NO." AND "QUANTITY" SHOULD INDICATE ON THE PACKAGE.	Minor
	2. MODEL MIXED AND QUANTITY	OTHER MODEL MIXED.....REJECTED QUANTITY SHORT OR OVER.....REJECTED	Critical
	3. PRODUCT INDICATION	"MODEL NO." SHOULD INDICATE ON THE PRODUCT	Major
ASSEMBLY	4. DIMENSION, LCD GLASS SCRATCH AND SCRIBE DEFECT.	ACCORDING TO SPECIFICATION OR DRAWING.	Major
APPEARANCE	5. VIEWING AREA	POLARIZER EDGE OR LCD'S SEALING LINE IS VISABLE IN THE VIEWING AREAREJECTED	Minor
	6. BLEMISH · BLACK SPOT · WHITE SPOT IN THE LCD AND LCD GLASS CRACKS	ACCORDING TO STANDARD OF VISUAL INSPECTION(INSIDE VIEWING AREA)	Minor
	7. BLEMISH · BLACK SPOT WHITE SPOT AND SCRATCH ON THE POLARIZER	ACCORDING TO STANDARD OF VISUAL INSPECTION(INSIDE VIEWING AREA)	Minor
	8. BUBBLE IN POLARIZER	ACCORDING TO STANDARD OF VISUAL INSPECTION(INSIDE VIEWING AREA)	Minor
	9. LCD'S RAINBOW COLOR	STRONG DEVIATION COLOR (OR NEWTON RING) OF LCD.....REJECTED. OR ACCORDING TO LIMITED SAMPLE (IF NEEDED, AND INSIDE VIEWING AREA)	Minor
ELECTRICAL	10. ELECTRICAL AND OPTICAL CHARACTERISTICS (CONTRAST· VOP · CHROMATICITY ... ETC)	ACCORDING TO SPECIFICATION OR DRAWING . (INSIDE VIEWING AREA)	Critical
	11.MISSING LINE	MISSING DOT · LINE · CHARACTERREJECTED	Critical
	12.SHORT CIRCUIT· WRONG PATTERN DISPLAY	NO DISPLAY · WRONG PATTERN DISPLAY · CURRENT CONSUMPTION OUT OF SPECIFICATION..... REJECTED	Critical
	13. DOT DEFECT (FOR COLOR AND TFT)	ACCORDING TO STANDARD OF VISUAL INSPECTION	Minor

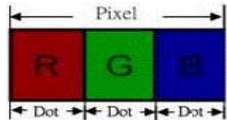

NO.	CLASS	ITEM	JUDGEMENT									
11.4.1	MINOR	BLACK AND WHITE SPOT FOREIGN MATERIEL DUST IN THE CELL BLEMISH SCRATCH	(A) ROUND TYPE: unit: mm <table border="1" style="width:100%"> <tr> <th>DIAMETER (mm.)</th> <th>ACCEPTABLE Q'TY</th> </tr> <tr> <td>$\varnothing \leq 0.1$</td> <td>Disregard</td> </tr> <tr> <td>$0.1 < \varnothing \leq 0.25$</td> <td>3 (Distance $\geq 5\text{mm}$)</td> </tr> <tr> <td>$0.25 < \varnothing$</td> <td>0</td> </tr> </table> <p style="text-align:center">NOTE: $\varnothing = (\text{LENGTH} * \text{WIDTH}) / 2$</p>	DIAMETER (mm.)	ACCEPTABLE Q'TY	$\varnothing \leq 0.1$	Disregard	$0.1 < \varnothing \leq 0.25$	3 (Distance $\geq 5\text{mm}$)	$0.25 < \varnothing$	0	
			DIAMETER (mm.)	ACCEPTABLE Q'TY								
$\varnothing \leq 0.1$	Disregard											
$0.1 < \varnothing \leq 0.25$	3 (Distance $\geq 5\text{mm}$)											
$0.25 < \varnothing$	0											
(S) ROUND TYPE: unit: mm <table border="1" style="width:100%"> <tr> <th>LENGTH</th> <th>WIDTH</th> <th>ACCEPTABLE QTY</th> </tr> <tr> <td>.....</td> <td>$W \leq$</td> <td>Disregard</td> </tr> <tr> <td>$L \leq 5.0$</td> <td>$0.03 < W \leq 0.07$</td> <td>3 (Distanced $\geq 5\text{mm}$)</td> </tr> <tr> <td>.....</td> <td>$0.07 < W$</td> <td>FOLLOW ROUND TYPE</td> </tr> </table> <p style="text-align:center">NOTE: $\varnothing = (\text{LENGTH} * \text{WIDTH}) / 2$</p>	LENGTH	WIDTH	ACCEPTABLE QTY	$W \leq$	Disregard	$L \leq 5.0$	$0.03 < W \leq 0.07$	3 (Distanced $\geq 5\text{mm}$)	$0.07 < W$	FOLLOW ROUND TYPE
LENGTH	WIDTH	ACCEPTABLE QTY										
.....	$W \leq$	Disregard										
$L \leq 5.0$	$0.03 < W \leq 0.07$	3 (Distanced $\geq 5\text{mm}$)										
.....	$0.07 < W$	FOLLOW ROUND TYPE										
11.4.2	MINOR	BUBBLE IN POLARIZER DENT ON POLARIZER	unit: mm. <table border="1" style="width:100%"> <tr> <th>DIAMETER</th> <th>ACCEPTABLE Q'TY</th> </tr> <tr> <td>$\varnothing < 0.2$</td> <td>Disregard</td> </tr> <tr> <td>$0.2 < \varnothing \leq 0.5$</td> <td>2(Distance $\geq 15\text{mm}$)</td> </tr> <tr> <td>$0.5 < \varnothing$</td> <td>0</td> </tr> </table>	DIAMETER	ACCEPTABLE Q'TY	$\varnothing < 0.2$	Disregard	$0.2 < \varnothing \leq 0.5$	2(Distance $\geq 15\text{mm}$)	$0.5 < \varnothing$	0	
DIAMETER	ACCEPTABLE Q'TY											
$\varnothing < 0.2$	Disregard											
$0.2 < \varnothing \leq 0.5$	2(Distance $\geq 15\text{mm}$)											
$0.5 < \varnothing$	0											
11.4.3	MINOR	Dot Defect	<table border="1" style="width:100%"> <tr> <th>Items</th> <th>ACC. Q'TY</th> </tr> <tr> <td>Bright dot</td> <td>$N \leq 4$(Distance $\geq 5\text{mm}$)</td> </tr> <tr> <td>Dark dot</td> <td>$N \leq 4$(Distance $\geq 5\text{mm}$)</td> </tr> </table> <p>Pixel Define :</p>  <p>Note:</p> <ol style="list-style-type: none"> The definition of dot: The size of a defective dot over 1 of whole dot is regarded as one defective dot. Definition: $< 1/2$ dot and visible by 5% ND filter Bright dot: Dots appear bright and unchanged in size m which LCD panel is displaying under black pattern. Dark dot: Dots appear dark and unchanged in size in which LCD panel is displaying under pure Red, Green, Blue pattern. 	Items	ACC. Q'TY	Bright dot	$N \leq 4$ (Distance $\geq 5\text{mm}$)	Dark dot	$N \leq 4$ (Distance $\geq 5\text{mm}$)			
Items	ACC. Q'TY											
Bright dot	$N \leq 4$ (Distance $\geq 5\text{mm}$)											
Dark dot	$N \leq 4$ (Distance $\geq 5\text{mm}$)											
11.4.3.1	MINOR	Mura	Not visible through 5% ND filter in 50% gray or judge by limit sample if necessary									

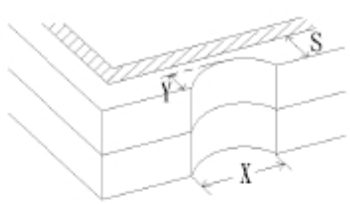
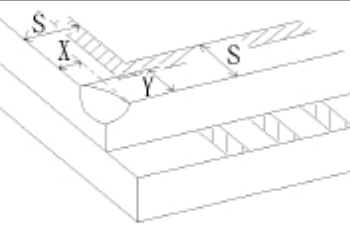
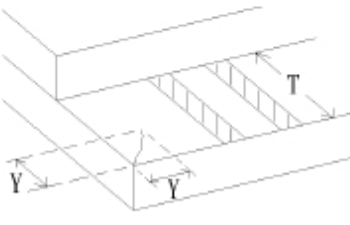
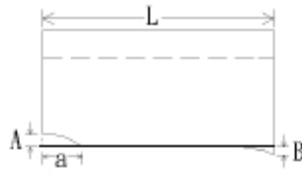
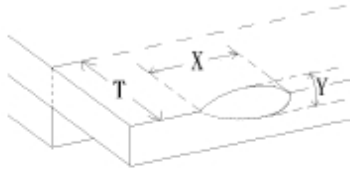
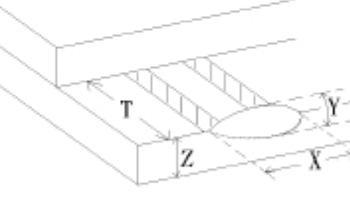
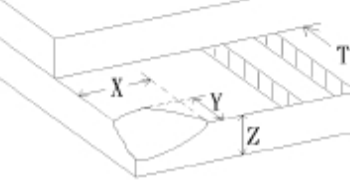

NO.	CLASS	ITEM	JUDGEMENT
11.4.4	MINOR	LCD GLASS CHIPPING	 $Y > S$ Reject
11.4.5	MINOR	LCD GLASS CHIPPING	 $X \text{ or } Y > S$ Reject
11.4.6	MAJOR	LCD GLASS GLASS CRACK	 $Y > (1/2) T$ Reject
11.4.7	MAJOR	LCD GLASS SCRIBE DEFECT	 <ol style="list-style-type: none"> $a > L/3$, $A > 1.5\text{mm}$. Reject B : ACCORDING TO DIMENSION
11.4.8	MINOR	LCD GLASS CHIPPING (ON THE TERMINAL AREA)	 $\Phi = (x+y)/2 > 2.5 \text{ mm}$ Reject
11.4.9	MINOR	LCD GLASS CHIPPING (ON THE TERMINAL SURFACE)	 $Y > (1/3) T$ Reject
11.4.10	MINOR	LCD GLASS CHIPPING	 $Y > T$ Reject

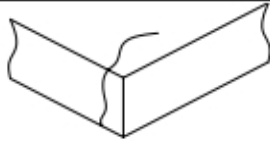
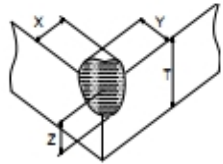
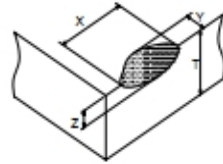

NO.	CLASS	ITEMS		JUDGEMENT			
11.5.1	MAJOR	Touch Panel Crack			Reject		
11.5.2	MINOR	Touch Panel Chipping	Corner		Not CNC Products	$X \leq 2\text{mm}, Y \leq 2\text{mm}, Z < 1/2T$	Accept
			Edge		Not CNC Products	$X \leq 3\text{mm}, Y \leq 3\text{mm}, Z < 1/2T$	Accept
11.5.3	MINOR	Scratch Dust and Foreign materiel (Linear Type)		$W \leq 0.05, L \leq 10\text{mm}$		Accept	
				$0.05\text{mm} < W \leq 0.07\text{mm}; L \leq 5.0\text{mm}$ Distance between seratch $> 5.0\text{mm}$		Accept 3 ea Max.	
				$W > 0.07\text{mm}$		Reject	
11.5.4	MINOR	Scratch Dust and Foreign materiel (Round Type : $\Phi = (\text{Length} + \text{Width})/2$)		$\Phi \leq 0.15\text{mm}$		Accept	
				$0.15\text{mm} < \Phi \leq 0.25\text{mm}$ Distance between seratch $> 5.0\text{mm}$		Accept 5 ea Max.	
				$\Phi > 0.25\text{mm}$		Reject	
11.5.5	MINOR	Touch Panel Dent / Fish Eyes ($\Phi = (\text{Length} + \text{Width})/2$)		$\Phi \leq 0.35\text{mm}$		Accept	
				$0.35\text{mm} < \Phi \leq 1.0\text{mm}$ Distance $> 5.0\text{mm}$		Accept 3 ea Max.	
				$\Phi > 1.0\text{mm}$		Reject	
11.5.6	MINOR	Touch Panel Air Bubble ($\Phi = (\text{Length} + \text{Width})/2$)		$\Phi \leq 0.15\text{mm}$		Accept	
				$0.15\text{mm} < \Phi \leq 0.25\text{mm}$ Distance between bubbles $> 5.0\text{mm}$		Accept 3 ea Max.	
				$\Phi > 0.25\text{mm}$		Reject	
11.5.7	MINOR	Touch Panel Printing area Scratch		$W \leq 0.03, L \leq 10\text{mm}$		Accept	
				$0.03\text{mm} < W \leq 0.05\text{mm}, L \leq 5\text{mm}$		Accept 3 ea Max.	
				$W > 0.05\text{mm}$ or $L > 5\text{mm}$ ($W > 0.05$ Follow 8.5.4 Round type)		Reject	
11.5.8	MINOR	Touch Panel White Haze Mark / Dust		Can not be removed		Reject	



12. Handling Precautions

12.1 Mounting method

The LCD panel of KINGTECH module consists of two thin glass plates with polarizes which easily be damaged. And since the module is constructed as to be fixed by utilizing fitting holes in the printed circuit board, extreme care should be needed when handling the LCD modules.

12.2 Caution of LCD handling and cleaning

When cleaning the display surface, Use soft cloth with solvent [Recommended below] and wipe lightly

- Isopropyl alcohol
- Ethyl alcohol

Do not wipe the display surface with dry or hard materials that will damage the polarizer surface.

Do not use the following solvent:

- Water
- Aromatics

Do not wipe ITO pad area with the dry or hard materials that will damage the ITO patterns.

Do not use the following solvent on the pad or prevent it from being contaminated:

- Soldering flux
- Chlorine (Cl) , Sulfur (S)

If goods were sent without being silicon coated on the pad, ITO patterns could be damaged due to the corrosion as time goes on.

If ITO corrosion happen by miss-handling or using some materials such as Chlorine (Cl), Sulfur (S) from customer, Responsibility is on customer.

12.3 Caution against static charge

The LCD module use C-MOS LSI drivers, so we recommended that you:

Connect any unused input terminal to POWER or GROUND, do not input any signals before power is turned on, and ground your body, work/assembly areas, and assembly equipment to protect against static electricity.

12.4 packing

- Module employs LCD elements and must be treated as such.
- Avoid intense shock and falls from a height.
- To prevent modules from degradation, do not operate or store them exposed direct to sunshine or high temperature/humidity

12.5 Caution for operation

- It is an indispensable condition to drive LCD's within the specified voltage limit since the higher voltage then the limit cause the shorter LCD life.
- An electrochemical reaction due to direct current causes LCD's undesirable deterioration, so that the use of direct current drive should be avoided.
- Response time will be extremely delayed at lower temperature then the operating temperature range and on the other hand at higher temperature LCD's how dark color in them. However those phenomena do not mean malfunction or out of order with



- LCD's, which will come back in the specified operation temperature.
- If the display area is pushed hard during operation, some font will be abnormally displayed but it resumes normal condition after turning off once.
- Slight dew depositing on terminals is a cause for electro-chemical reaction resulting in terminal open circuit.

Usage under the maximum operating temperature, 50%Rh or less is required.

12.6 Storing

In the case of storing for a long period of time for instance, for years for the purpose or replacement use, the following ways are recommended.

- Storage in a polyethylene bag with the opening sealed so as not to enter fresh air outside in it. And with no desiccant.
- Placing in a dark place where neither exposure to direct sunlight nor light's keeping the storage temperature range.
- Storing with no touch on polarizer surface by the anything else.
- [It is recommended to store them as they have been contained in the inner container at the time of delivery from us

12.7 Safety

- It is recommendable to crash damaged or unnecessary LCD's into pieces and wash off liquid crystal by either of solvents such as acetone and ethanol, which should be burned up later.
- When any liquid leaked out of a damaged glass cell comes in contact with your hands, please wash it off well with soap and water

13. Precaution for Use

13.1

A limit sample should be provided by the both parties on an occasion when the both parties agreed its necessity. Judgment by a limit sample shall take effect after the limit sample has been established and confirmed by the both parties.

13.2

On the following occasions, the handing of problem should be decided through discussion and agreement between responsible of both parties.

- When a question is arisen in this specification
- When a new problem is arisen which is not specified in this specification.
- When an inspection specification change or operating condition change in customer is reported to KINGTECH and some problem is arisen in this specification due to the change
- When a new problem is arisen at the customer's operating set for sample evaluation in the customer site.

14. Packing Method

TBD