



承认 编码: CR _____

TFT LCD MODULE
3.5 inch 320RGB*480DOTS

MODULE NUMBER: PV035HV-CINA5007-CT

REVISION: V00

Customer Approval:

--

- Approved For Specifications
- Approved For Specifications & Sample**

Prepared by	Checked by	Approved by



Index

Contents	Page
1. LCM Specification	4
2. Mechanical Specification... ..	5
3. Pin Descriptions	6
4. Electrical Units.....	7
5. AC Characteristics	8
6. Power On/Off Sequence... ..	10
7. Optical Specifications... ..	11
8. Reliability Test Items... ..	14
9. Handling Precautions... ..	15
10. QC... ..	18



1. LCM Specification

1.1 Description

PV035HV-CINA5007-CT is a transmissive type color active matrix liquid crystal display(LCD) which uses amorphous thin film transistor(TFT) as switching devices. This product is composed of a TFT LCD panel, a drive IC , a FPC and a LED-backlight unit. The active display area is 3.5 inches diagonally measured and the native resolution is 320*RGB*480.Features of this product are listed in the following table.

1.2 Functions & Features

Table 1.1 Module Functions & Features

Parameter	Value	Unit
LCD Mode	TFT/Transmissive	-
Color Depth	262K	-
Display Resolution	320RGB*480	pixels
Module Size	54.66(H)*84.18(W)*3.55(T)(Exclude FPC)	mm
Active Area (A.A)	48.96(H)*73.44(W)	mm
Pixel Arrangement	RGB-stripe	-
Viewing Direction	ALL	
Display Mode	Normally Black	
LCD Controller/Driver	ILI9488	-
IC Package Type	COG	-
Interface	8-/ 9-/16-/18- 8080-MCU 4-lines / 3-lines SPI + 16-/18-bit RGB	-
Power Supply Voltage	2.8	V
LCM Brightness	350	cd /m ²
Back-light	White LED*6	PCS



3. Pin Descriptions

Pin No.	Symbol	I/O	Functional	Remark																																				
1	GND	P	System ground.																																					
2~3	IOVCC	P	I/O Power supply, 1.65~3.3V.																																					
4~5	VCI	P	Power supply, 2.5~3.3V.																																					
6	IM0	I	<table border="1"> <thead> <tr> <th>IM2</th> <th>IM1</th> <th>IM0</th> <th>Interface</th> </tr> </thead> <tbody> <tr> <td>0</td> <td>0</td> <td>0</td> <td>MIPI-DBI Type B 24-bit bus (DB_EN = 1)</td> </tr> <tr> <td>0</td> <td>0</td> <td>0</td> <td>MIPI-DBI Type B 18-bit bus (DB_EN = 0)</td> </tr> <tr> <td>0</td> <td>0</td> <td>1</td> <td>MIPI-DBI Type B 9-bit bus</td> </tr> <tr> <td>0</td> <td>1</td> <td>0</td> <td>MIPI-DBI Type B 16-bit bus</td> </tr> <tr> <td>0</td> <td>1</td> <td>1</td> <td>MIPI-DBI Type B 8-bit bus</td> </tr> <tr> <td>1</td> <td>0</td> <td>1</td> <td>MIPI-DBI Type C Option 1 (3-line SPI)</td> </tr> <tr> <td>1</td> <td>1</td> <td>0</td> <td>MIPI DSI</td> </tr> <tr> <td>1</td> <td>1</td> <td>1</td> <td>MIPI-DBI Type C Option 3 (4-line SPI)</td> </tr> </tbody> </table>	IM2	IM1	IM0	Interface	0	0	0	MIPI-DBI Type B 24-bit bus (DB_EN = 1)	0	0	0	MIPI-DBI Type B 18-bit bus (DB_EN = 0)	0	0	1	MIPI-DBI Type B 9-bit bus	0	1	0	MIPI-DBI Type B 16-bit bus	0	1	1	MIPI-DBI Type B 8-bit bus	1	0	1	MIPI-DBI Type C Option 1 (3-line SPI)	1	1	0	MIPI DSI	1	1	1	MIPI-DBI Type C Option 3 (4-line SPI)	
IM2	IM1	IM0		Interface																																				
0	0	0		MIPI-DBI Type B 24-bit bus (DB_EN = 1)																																				
0	0	0		MIPI-DBI Type B 18-bit bus (DB_EN = 0)																																				
0	0	1		MIPI-DBI Type B 9-bit bus																																				
0	1	0		MIPI-DBI Type B 16-bit bus																																				
0	1	1		MIPI-DBI Type B 8-bit bus																																				
1	0	1		MIPI-DBI Type C Option 1 (3-line SPI)																																				
1	1	0	MIPI DSI																																					
1	1	1	MIPI-DBI Type C Option 3 (4-line SPI)																																					
7	IM1	I																																						
8	IM2	I																																						
9	RESET	I	Reset signal pin.																																					
10	VSYNC	I	Frame synchronizing signal for RGB interface operation.																																					
11	HSYNC	I	Line synchronizing signal for RGB interface operation.																																					
12	PCLK	I	Dot clock signal for RGB interface operation.																																					
13	DE	I	Data enable signal for RGB interface operation.																																					
14~31	DB17~DB0	I/O	Data bus.																																					
32	TE	O	Tearing effect output.(NC)																																					
33	SDO	O	Serial data output.																																					
34	SDA	I/O	Serial data input.																																					
35	RD	I	RD (read strobe signal) ,Fix to GND when not in use.																																					
36	WR/SCL	I	Serves Write signal or serial interface clock .																																					
37	RS	I	Data / Command Selection pin, Fix to GND when not in use.																																					
38	CS	I	A chip select signal.																																					
39	XR	I	No Connection.																																					
40	YD	I	No Connection.																																					
41	XL	I	No Connection.																																					
42	YU	I	No Connection.																																					
43	LEDA	P	LED Power supply +																																					
44~49	LEDK	P	LED Power supply -																																					
50	GND	P	System ground.																																					



CTP PIN descriptions

Pin	Symbol	Description.
1	RESET	CTP reset pin. Active low to enter reset state.
2	INT	CTP interruption signal.
3	SDA	CTP I2C_data.
4	SCL	CTP I2C_clock.
5	GND	Power Ground.
6	VDD	CTP Power supply 2.8~3.3V.

4. Electrical Units

4.1 Absolute Maximum Ratings

The absolute maximum ratings are list on Table 4.1. When used out of the absolute maximum ratings, the LCM may be permanently damaged. Using the LCM within the following electrical characteristics limit is strongly recommended for normal operation. If these electrical characteristic conditions are exceeded during normal operation, the LCM will malfunction and cause poor reliability.

Table 4.1 Module Absolute Maximum Ratings

Item	Symbol	Unit	Value	Note
Power Supply Voltage	VCI	V	-0.3 to +3.3	
Power Supply Voltage	IOVCC	V	-0.3 to +3.3	
Operating Temperature	Top	°C	-20 to +70	
Storage Temperature	Tst	°C	-30 to +80	
Operating Humidity	Hop	%(RH)	90	

(VSS=0V)

4.2 Electrical characteristics (Ta=25°C)

Table 4.2:DC Characteristic (Vcc = 3.0 ~ 3.6V)

Item	Symbol	Condition	Min.	Ty	Max.	Unit	
Supply Voltage	Logic	VCI	---	2.5	2.8	3.3	V
Supply Voltage	I/O	IOVCC	---	1.65	2.8	3.3	V
Input Voltage	H level	V _{IH}	---	0.8IOV _{cc}	---	V _{dd}	V
	L level	V _{IL}	---	0	---	0.2IOV _{cc}	
Current Consumption	I _{cc}	With internal voltage generation; VCC=2.8V;	---	8	20	mA	



4.3 ack-light Specification

Table 4.3 Back-light Characteristics

Item	Symbol	Conditions	Min.	Type.	Max.	Unit
Supply Voltage	VF	Only Backlight	2.7	3.0	3.4	V
Supply Current	IF		120			mA
Uniformity	B	Backlight Current IF=120mA	--	80%	—	%
Color	White					

Note: 6 LEDs in parallel connection.

5. AC Characteristics

5.1 MCU 8-/9-/16-/18-bit interfae Characteristics.

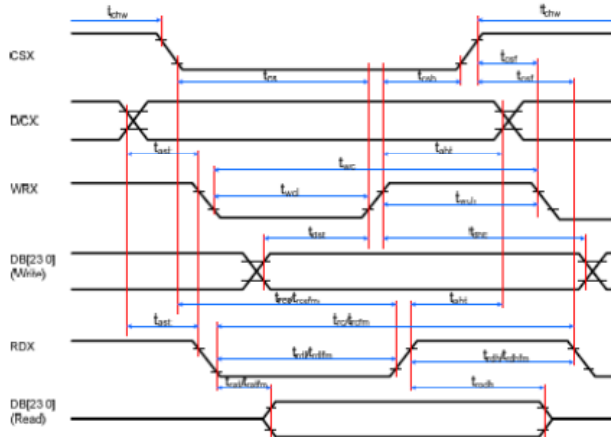

Signal	Symbol	Parameter	min	max	Unit	Description
DCX	tast	Address setup time	0	-	ns	-
	that	Address hold time (Write/Read)	0	-	ns	-
CSX	tchwh	CSX 'H' pulse width	0	-	ns	-
	tcs	Chip Select setup time (Write)	15	-	ns	-
	trcs	Chip Select setup time (Read ID)	45	-	ns	-
	trcsfm	Chip Select setup time (Read FM)	355	-	ns	-
WRX	tcsf	Chip Select Wait time (Write/Read)	0	-	ns	-
	twc	Write cycle	30	-	ns	-
	twh	Write Control pulse H duration	15	-	ns	-
RDX (FM)	twhl	Write Control pulse L duration	15	-	ns	-
	trcfm	Read Cycle (FM)	450	-	ns	When read from Frame Memory
	trdthm	Read Control H duration (FM)	90	-	ns	
	trdlfm	Read Control L duration (FM)	355	-	ns	
RDX (ID)	trc	Read cycle (ID)	160	-	ns	When read ID data
	trdh	Read Control pulse H duration	90	-	ns	
	trdl	Read Control pulse L duration	45	-	ns	
DB [23:0], DB [17:0], DB [15:0], DB [8:0], DB [7:0]	tdst	Write data setup time	10	-	ns	For maximum, CL=30pF For minimum, CL=8pF
	tdht	Write data hold time	10	-	ns	
	trat	Read access time	-	40	ns	
	tratfm	Read access time	-	340	ns	
	trod	Read output disable time	20	80	ns	



5.2 3-Line SPI Interface Characteristic

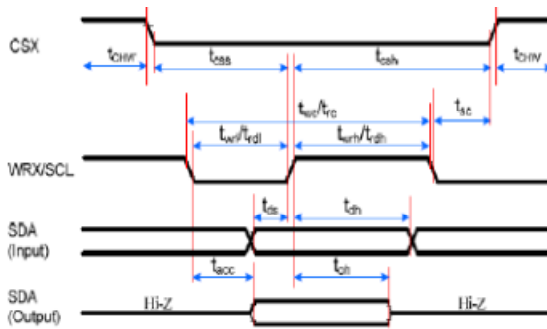

Signal	Symbol	Parameter	min	max	Unit	Description
CSX	tsc	SCL-CSX	15	-	ns	
	tchW	CSX H Pulse Width	40	-	ns	
	tcss	Chip select time (Write)	60	-	ns	
	tchsh	Chip select hold time (Read)	65	-	ns	
SCL	tsc	Serial Clock Cycle (Write)	66	-	ns	
	twh	SCL H Pulse Width (Write)	15	-	ns	
	twl	SCL L Pulse Width (Write)	15	-	ns	
	trc	Serial Clock Cycle (Read)	150	-	ns	
	trdh	SCL H Pulse Width (Read)	60	-	ns	
	trdl	SCL L Pulse Width (Read)	60	-	ns	
SDA/SDI (Input)	tds	Data setup time (Write)	10	-	ns	
	tdh	Data hold time (Write)	10	-	ns	
SDA/SDO (Output)	tacc	Access time (Read)	10	50	ns	For maximum CL=30pF For minimum CL=8pF
	tch	Output disable time (Read)	15	50	ns	

Note: Ta = -30 to 70 °C, IOVCC = 1.65V to 3.6V, VCI = 2.5V to 3.6V, AGND = DGND = 0V, T = 10+/-0.5ns

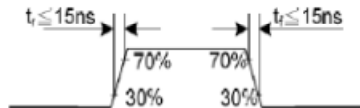

5.3 4-Line SPI Interface Characteristic

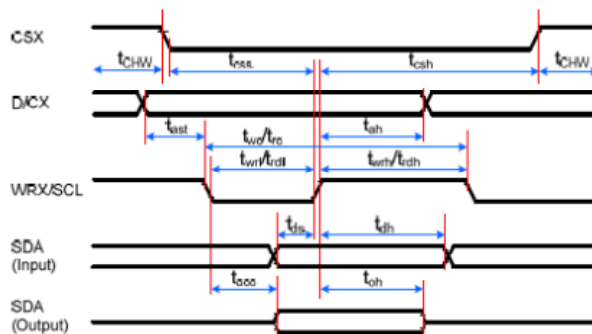

Signal	Symbol	Parameter	min	max	Unit	Description
CSX	tcss	Chip select time (Write)	15	-	ns	
	tchsh	Chip select hold time (Read)	15	-	ns	
	tchW	CS H pulse width	40	-	ns	
SCL	tsc	Serial clock cycle (Write)	50	-	ns	
	twh	SCL H pulse width (Write)	10	-	ns	
	twl	SCL L pulse width (Write)	10	-	ns	
	trc	Serial clock cycle (Read)	150	-	ns	
	trdh	SCL H pulse width (Read)	60	-	ns	
	trdl	SCL L pulse width (Read)	60	-	ns	
D/CX	tas	D/CX setup time	10	-	ns	
	tah	D/CX hold time (Write/Read)	10	-	ns	
SDA/SDI (Input)	tds	Data setup time (Write)	10	-	ns	
	tdh	Data hold time (Write)	10	-	ns	
SDA/SDO (Output)	tacc	Access time (Read)	10	50	ns	For maximum CL=30pF For minimum CL=8pF
	tod	Output disable time (Read)	15	50	ns	

Notes:

- Ta = -30 to 70 °C, IOVCC = 1.65V to 3.3V, VCI = 2.5V to 3.3V, AGND = DGND = 0V, T = 10+/-0.5ns.
- Does not include signal rising and falling times.



5.4 DPI 18-bit RGB Interface Characteristics

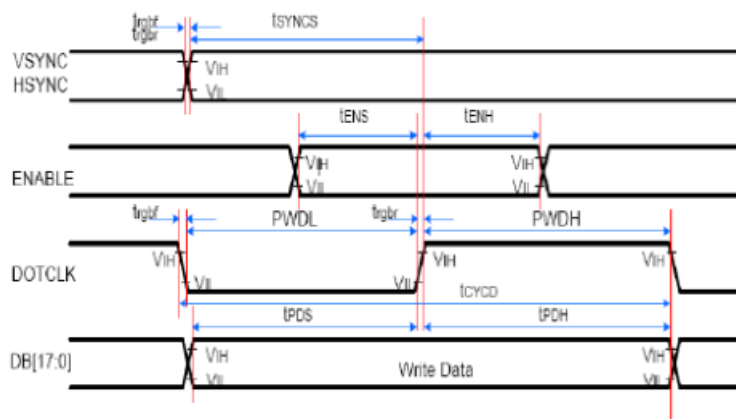

Signal	Symbol	Parameter	min	max	Unit	Description
VSYNC/HSYNC	t_{sncs}	VSYNC/HSYNC setup time	15	-	ns	16/18-/24-bit bus RGB interface mode
HSYNC	t_{snch}	VSYNC/HSYNC hold time	15	-	ns	
ENABLE	t_{se}	ENABLE setup time	15	-	ns	
	t_{sh}	ENABLE hold time	15	-	ns	
DB [23:0]	t_{cs}	Data setup time	15	-	ns	
	t_{ch}	Data hold time	15	-	ns	
DOTCLK	$PWDH$	DOTCLK high-level period	20	-	ns	
	$PWDL$	DOTCLK low-level period	20	-	ns	
	t_{cyc}	DOTCLK cycle time	50	-	ns	
	t_{pr}, t_{pt}	DOTCLK,HSYNC,VSYNC rise/fall time	-	15	ns	

Note: $T_a = -30$ to 70 °C, IOVCC = 1.65V to 3.3V, VCI = 2.5V to 3.3V, AGND = DGND = 0V

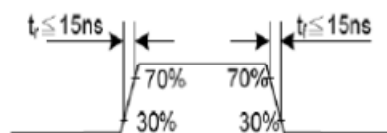

6. Power On/Off Sequence

Power source IOVCC, VCI can be applied and powered down in any order.

IOVCC, VCI can be powered down in any order.

During power off, if LCD is in the Sleep Out mode, IOVCC, VCI must be powered down minimum 120msec after NRESET has been released.

During power off, if LCD is in the Sleep In mode, IOVCC, VCI can be powered down minimum 0msec after NRESET has been released.

NCS can be applied at any timing or can be permanently grounded. NRESET has priority over NCS.

- Note:**
- (1) There will be no damage to the display module if the power sequences are not met.
 - (2) There will be no abnormal visible effects on the display panel during the Power On/Off Sequences.
 - (3) There will be no abnormal visible effects on the display between end of Power on Sequence and before receiving Sleep Out command. Also between receiving Sleep In command and Power Off Sequence.
 - (4) If NRESET line is not held stable by host during Power on Sequence as defined in Sections 5.11.1.1 and 5.11.1.2, then it will be necessary to apply a Hardware Reset (NRESET) after Host Power on Sequence to ensure correct operation. Otherwise correct function is not guaranteed.



7. Optical Specifications

	Item	Symbol	Condition	Specification			Unit	
				Min.	Typ.	Max.		
Backlight On (Transmissive Mode)	Luminance on TFT ($I_f=20\text{mA/LED}$)	Lv	Normally viewing angle $\theta_x = \phi_y = 0^\circ$	280	350	-	cd/m ²	
	Contrast ratio(See 7.2)	CR		-	700	-		
	Response time (See 7.1)	TR+TF		-	30	-	ms	
	Chromaticity Transmissive (See 7.4)	White	X _w	0.276	0.316	0.356	-	
			Y _w	0.282	0.322	0.362	-	
	Viewing Angle (See 7.3)	Horizontal	θ_{x+}	Center CR \geq 10	-	80	-	Deg.
			θ_{x-}		-	80	-	
		Vertical	ϕ_{y+}		-	80	-	
			ϕ_{y-}		-	80	-	
	NTSC Ratio(Gamut) (See 7.4)	-	-	-	69	-	%	



7.1 Definition of Response Time

7.1.1 Normally Black Type (Negative)

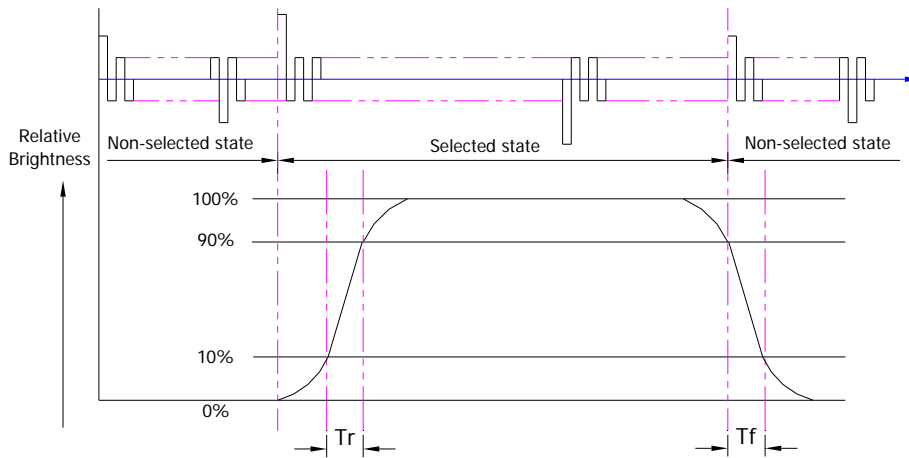

Tr is the time it takes to change from non-selected stage with relative luminance 10% to selected state with relative luminance 90%;

Tf is the time it takes to change from selected state with relative luminance 90% to non-selected state with relative luminance 10%.

Note : Measuring machine: LCD-5100

7.1.2 Normally White Type (Positive)

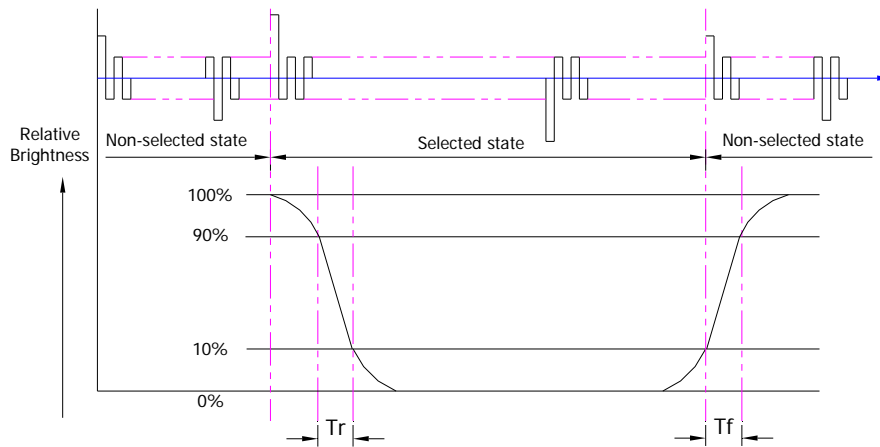

Tr is the time it takes to change from non-selected stage with relative luminance 90% to selected state with relative luminance 10%;

Tf is the time it takes to change from selected state with relative luminance 10% to non-selected state with relative luminance 90%;

Note : Measuring machine: LCD-5100 or EQUI

7.2 Definition of Contrast Ratio

Contrast is measured perpendicular to display surface in reflective and transmissive mode. The measurement condition is:

Measuring Equipment	Eldim or Equivalent
Measuring Point Diameter	3mm//1mm
Measuring Point Location	Active Area centre point
Test pattern	A: All Pixels white
	B: All Pixel black
Contrast setting	Maximum

Definitions: CR (Contrast) = Luminance of White Pixel / Luminance of Black Pixel



7.3 Definition of Viewing Angles

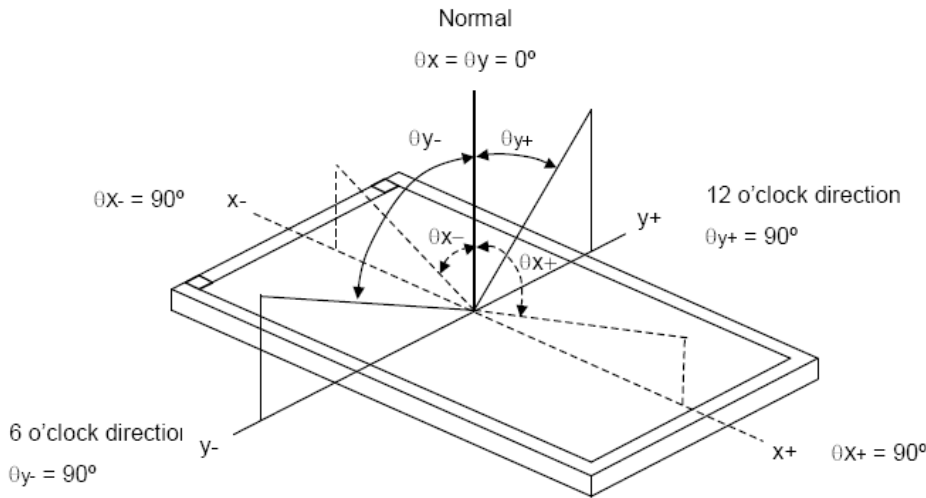

Measuring machine: LCD-5100 or EQUI

7.4 Definition of Color Appearance

R,G,B and W are defined by (x, y) on the IE chromaticity diagram

NTSC=area of RGB triangle/area of NTSC triangleX100%

Measuring picture: Red, Green, Blue and White (Measuring machine: BM-7)

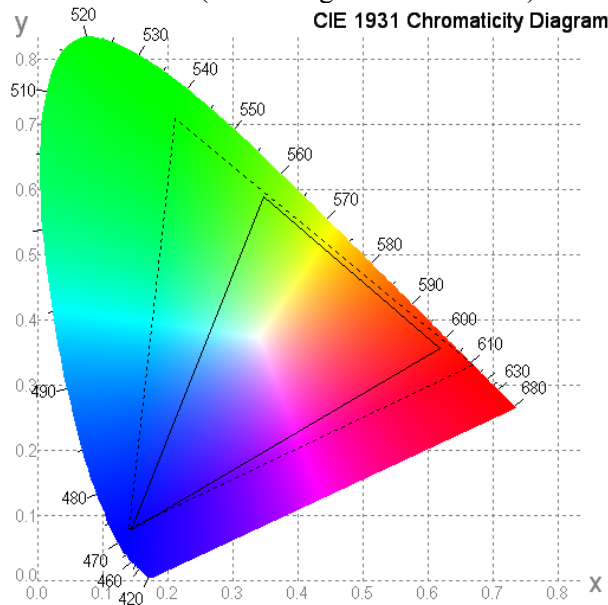



8. Reliability Test Items

No.	Test Item	Test Condition	Check Time
1	High temp storage	T=80°C	72Hrs
2	Low temp storage	T=-30°C	72Hrs
3	High temp operation	T=70°C	72Hrs
4	Low temp operation	T=-20°C	72Hrs
5	High temp & high humidity	T=50°C H=90%	72Hrs

Note1: Pass: Normal display image with no obvious non-uniformity and no line defect. Fail: No display image, obvious non-uniformity, or line defects. Partial transformation of the module parts should be ignored.

Note2: Evaluation should be tested after storage at room temperature for two hours.

Note3: Evaluation should be tested with storage temperature.



9. Handling Precautions

9.1 Mounting Method

The panel of the LCD consists of two thin glasses with polarizers which easily get damaged. So extreme care should be taken when handling the LCD.

Excessive stress or pressure on the glass of the LCD should be avoided. Care must be taken to insure that no torsional or compressive forces are applied to the LCD unit when it is mounted.

If the customer's set presses the main parts of the LCD, the LCD may show the abnormal display. But this phenomenon does not mean the malfunction of the LCD and should be pressed by the way of mutual agreement.

To determine the optimum mounting angle, refer to the viewing angle range in the specification for each model.

Mount a LCD module with the specified mounting parts.

9.2 Caution of LCD Handling and Cleaning

Since the LCD is made of glass, do not apply strong mechanical impact or static load onto it. Handling with care since shock, vibration, and careless handling may seriously affect the product. If it falls from a high place or receives a strong shock, the glass may be broken.

The polarizers on the surface of panel are made from organic substances. Be very careful for chemicals not to touch the polarizers or it leads the polarizers to be deteriorated.

If the use of a chemical is unavoidable, use soft cloth with solvent (recommended below) to clean the LCD's surface with wipe lightly.

-IPA(Isopropyl Alcohol), Ethyl Alcohol, Trichlorotrifluoroethane

Do not wipe the LCD's surface with dry or hard materials that will damage the polarizers and others. Do not use the following solvent.

-Water, Ketone, Aromatics

It is recommended that the LCD be handled with soft gloves during assembly, etc. The polarizers on the LCD's surface are vulnerable to scratch and thus to be damaged by sharp particles.

Do not drop water or any chemicals onto the LCD's surface.

A protective film is supplied on the LCD and should be left in place until the LCD is required for operation.

The ITO pad area needs special careful caution because it could be easily corroded. Do not contact the ITO pad area with HCFC, Soldering flux, Chlorine, Sulfur, saliva or fingerprint.

To prevent the ITO corrosion, customers are recommended that the ITO area would be covered by UV or silicon.

9.3 Caution Against Static Charge

The LCD modules use C-MOS LSI drivers, so customers are recommended that any unused input terminal would be connected to Vdd or Vss, do not input any signals before power is turn on, and ground you body, work/assembly area, assembly equipments to protect against static electricity.



Remove the protective film slowly, keeping the removing direction approximate 30-degree not vertical from panel surface, If possible, under ESD control device like ion blower, and the humidity of working room should be kept over 50%RH to reduce the risk of static charge.

Avoid the use work clothing made of synthetic fibers. We recommend cotton clothing or other conductivity-treated fibers.

In handling the LCD, wear non-charged material gloves. And the conducting wrist to the earth and the conducting shoes to the earth are necessary.

9.4 Caution For operation

It is indispensable to drive the LCD within the specified voltage limit since the higher Voltage than the limit causes the shorter LCD's life. An electro-chemical reaction due to DC causes undesirable deterioration of the LCD so that the use of DC drive should avoid.

Do not connect or disconnect the LCD to or from the system when power is on.

Never use the LCD under abnormal conditions of high temperature and high humidity.

When expose to drastic fluctuation of temperature (hot to cold or cold to hot) ,the LCD may be affected; Specifically, drastic temperature fluctuation from cold to hot ,produces dew on the LCD's surface which may affect the operation of the polarizer and the LCD.

Response time will be extremely delayed at lower temperature than the operating temperature range and on the other hand at higher temperature LCD may turn black at temperature above its operational range. However those phenomena do not mean malfunction or out of order with the LCD. The LCD will revert to normal operation once the temperature returns to the recommended temperature range for normal operation.

Do not display the fixed pattern for a long time because it may develop image sticking due to the LCD structure. If the screen is displayed with fixed pattern, use a screen saver.

9.5 Packaging

Modules use LCD element, and must be treated as such.

-Avoid intense shock and falls from a height.

-To prevent modules from degradation, do not operate or store them exposed directly to suns hine or high temperature/humidity for long periods.

9.6 Storage

A slight dew depositing on terminals is a cause for electro-chemical reaction resulting in terminal open circuit. Relative humidity of the environment should therefore be kept below 60%RH.

Original protective film should be used on LCD's surface (polarizer). Adhesive type protective film should be avoided, because it may change color and/or properties of the polarizers.

Do not store the LCD near organic solvents or corrosive gasses.

Keep the LCD safe from vibration, shock and pressure.



Black or white air-bubbles may be produced if the LCD is stored for long time in the lower temperature or mechanical shocks are applied onto the LCD.

In the case of storing for a long period of time for the purpose or replacement use, the following ways are recommended.

- Store in a polyethylene bag with sealed so as not to enter fresh air outside in it.
- Store in a dark place where neither exposure to direct sunlight nor light is.
- Keep temperature in the specified storage temperature range.
- Store with no touch on polarizer surface by the anything else. If possible, store the LCD in the packaging situation LCD when it was delivered.

9.7 Safety

For the crash damaged or unnecessary LCD, it is recommended to wash off liquid crystal by either of solvents such as acetone and ethanol and should be burned up later.

In the case the LCD is broken, watch out whether liquid crystal leaks out or not. If your hands touch the liquid crystal, wash your hands cleanly with water and soap as soon as possible.

If you should swallow the liquid crystal, first, wash your mouth thoroughly with water, then drink a lot of water and induce vomiting, and then, consult a physician.

If the liquid crystal should get in your eyes, flush your eyes with running water for at least fifteen minutes.

If the liquid crystal touches your skin or clothes, remove it and wash the affected part of your skin or clothes with soap and running water.



10. QC

10.1 Purpose

To ensure the stability of our product and standardize our inspection

10.2 Application Range

This standard is applied to all 4.3 inch and smaller sized LCM product from Elsun Technology Co.Ltd

10.3 Definition of inspection area

C area: The area covered after installation

B area: visible area

A area: display area

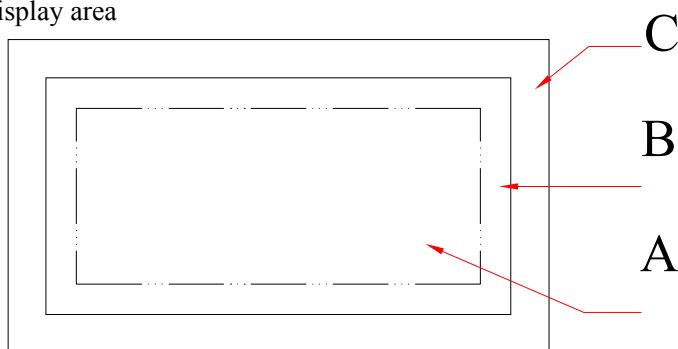

10.4 The environmental condition of inspection

Lighting conditions should be 20 ~ 40W fluorescent lamp (illumination at 1000 ± 200 lux)

Test ambient temperature should be 23 ± 5 °C, humidity at $50 \pm 20\%$ RH

The tested products should be placed 300mm away from the examiner's eye, and 30 degrees in the vertical direction observed within the region

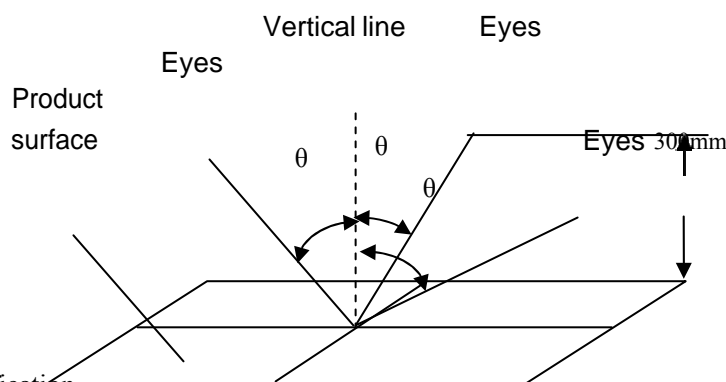

10.5 Identification

10.5.1 Bright dot: dots appearing bright and unchanged in size when the LCD panel is under black pattern.

10.5.2 Dark dot: dots appearing dark and unchanged size when the LCD panel is under RGB picture.

10.6 Inspection items and criteria



10.6.1 Serious defect

No	inspection item	inspection criteria	defect grade
10.6.1.1	function failure	1) Non-display not allowed 2) Line missing not allowed 3) Invalid touch and drift not allowed (if need)	main defect
10.6.1.2	break	broken display not allowed	main defect
10.6.1.3	dimension	Dimension tolerance out of specified in the drawing not allowed.	main defect

10.6.2 Appearance defect

No	Inspection item	inspection criteria	defect grade
10.6.2.1	Dot defect black dot, white dot, dirt on surface, stain, bubble	1. dot defect identification:	Minor defect
		2. inspection criteria range	

$$\Phi = \frac{(\chi + \gamma)}{2}$$

Area and quantit y dimension(mm)	quantity allowed		
	A area	B area	C area
$\Phi \leq 0.15$	ignore		ignore
$0.15 < \Phi \leq 0.20$	2 (spacing $\geq 10\text{mm}$)		
$0.20 < \Phi \leq 0.3$	1		
$\Phi > 0.3$	0		

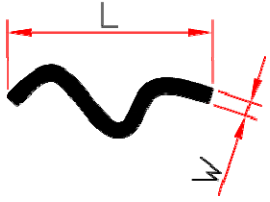

No	Inspection item	inspection criteria	defect grade			
10.6.2.2	line defect visible black/white line	1. identification of line dimension L: length W: width	Minor defect			
						
		2. inspection criteria				
		dimension(mm)		quantity allowed (total 3 pcs)		
		L (length)		W (width)	area	
					A area B area C area	
		ignore		$W \leq 0.03$	ignore	
$L \leq 3.0$	$0.03 < W \leq 0.05$	2	ignore			
$L \leq 3.0$	$0.05 < W \leq 0.08$	1				
	$W > 0.08$	count according to dot defect				
10.6.2.3	scratch	1-If the scratch is visible after installation or at work, refer to 10.6.2.2 2-If the scratch is visible at special angel or at non-working status, refer to the following standards	Minor defect			
		dimension (mm)		Quantity allowed		
		L (length)		W (width)	area	
					A B C	
		ignore		$W \leq 0.03$	ignore	ignore
		$5.0 < L \leq 10.0$		$0.03 < W \leq 0.05$	2	
		$L \leq 5.0$		$0.05 < W \leq 0.08$	1	
	$W > 0.08$	Not allowed				

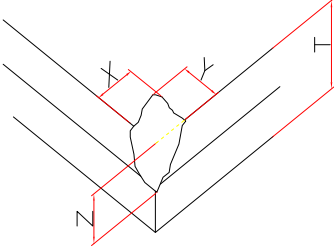
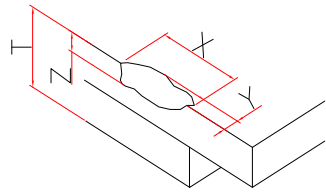
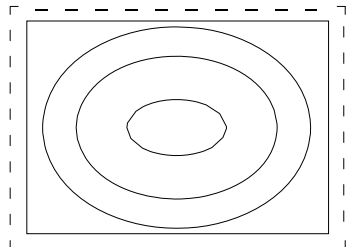
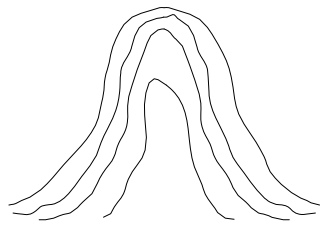

No	Inspection item	inspection criteria	defect grade
10.6.2.4	Glass defect	<p>1. broken angle</p> <p>X不计 Y≤2.0mm or X≤2.0mm Y不计 Meanwhile Z<T ignore</p>  <p>2. other broken part</p> <p>X≤5.0mm Y≤0.8mm Meanwhile Z≤T ignore</p> 	Minor defect
10.6.2.5	Newton ring	<p>1.regular Newton ring</p>  <p>①Newton ring area>1/3 T/P area; not acceptable. ② Newton ring area≤ 1/3 T/P area and doesn't affect the display result and no line distortion; acceptable</p> <p>2. Non-regular Newton ring</p>  <p>① Newton ring area > 1/2 T/P area, or no matter how big as long as it affects the display result; not acceptable Newton ring area ≤ 1/2 T/P area, and doesn't affect the display result and without line distortion; acceptable</p>	Minor defect



NO	Inspection item	inspection criteria	defect grade
10.6.2.6	FPC	<ol style="list-style-type: none"> 1. copper foil off, warping, crack and oxidation are not allowed 2. FPC crack, break, serious scratch and crease are not allowed 	main defect
		<ol style="list-style-type: none"> 3. if no special requirements, no release paper on double-sided adhesive FPC is not allowed. 4. Slight creases and scratches not exposed from the copper foil and with no affect to appearance and function are allowed. 5. if no special requirements, no insulating tape at welding part on backlight and touch-screen is not allowed.. 6. Parts off, breakage and deform are not allowed. 7. print on the surface should be clear and correct. 	Minor defect
10.6.2.7	basic appearance requirements	<ol style="list-style-type: none"> 1. clean appearance, no dirt, fingerprints and other traces. 2. ITO circuit on COG coating area should not be exposed. 3. Rust, sever scratch, deformation, obvious burrs and color dirt are not allowed. 4. Mis-assembly, part missing are not allowed. 5. Bubble caused by mis-pasted polaroid refers to 10.6.2.1 6. For watermark, the criteria is upon agreed by both parties. 	Minor defect



10.6.3 electric defect

No	Inspection item	inspection criteria	defect grade
10.6.3.1	picture defect	Non-display, more or less image and display defect are not allowed.	main defect
10.6.3.2	bright/dark line	Not allowed.	main defect
10.6.3.3	display dot defect	<ol style="list-style-type: none"> one dot is acceptable. Under bright status, 2 dark dots with more than 5mm distance is allowed. Totally 2 bright or dark dots are acceptable. The other defect under bright status refers to 10.6.2.1 <p>Note: Electric bright/dark dot means one pixel; less than 1/2 of 1 pixel can be ignored.</p>	Minor defect
10.6.3.4	connected dot/line defect	<ol style="list-style-type: none"> Two continuous defect pixel connected dots are not allowed. Line defect refers to 10.6.2.2 	Minor defect
10.6.3.5	wrong view direction	Wrong view directions, such as opposite view angle, are not allowed.	main defect
10.6.3.6	back light defect	<ol style="list-style-type: none"> Backlight off are not allowed. Uneven light, dead light, flicker light, dark angle, light leakage are not allowed. Brightness should comply with drawing 	main defect

end.