



产品承认书

产品名称: TFT LCD
产品型号: PV02819HZ39L
客户项目:
版本: V0
日期: 2021-02-20

客户 签回 (APPROVED BY CUSTOMER)	
--	--

制表 (Prepared by)	检查 (Checked by)	审核 (Approved by)



1. 机构说明 (GENERAL INFORMATION)

项目 (Item)	内容 (Contents)	单位
外型尺寸 (Outline dimensions)	48.4(W) * 68.52 (H) * 2.5 (T)	mm
显示尺寸 (Module size)	2.8	inch
显示分辨率 (Number of Dots)	240*320	-
动态显示区 (Active area)	43.2 (W) *57.6(H)	mm
像素大小 (Pixel pitch)	-	um
LCD 类型 (The LCD type)	IPS/全视角	-
视角方向 (Viewing direction)	ALL	-
驱动 IC (LCD Driver IC)	ST7789V	-
背光类型 (Backlight type)	4 颗(4*LED)	pcs



2.接口定义 (INTERFACE DESCRIPTION)

Pin No.	Symbol	Functional
1	GND	Ground
2	GND	Ground
3	LEDK	Backlight negative
4	LEDK	Backlight negative
5	LEDA	Backlight positive
6	LEDA	Backlight positive
7	GND	Ground
8	GND	Ground
9	VCC	Power supply
10	VCC	Power supply
11	IOVCC	Power supply
12	IOVCC	Power supply
13	GND	Ground
14	GND	Ground
15	RESET	Reset signal
16	CS	Chip select signal
17	RS/SCL	Register select signal/serial clock signal
18	WR/RS/SDA1	MCU write signal/ Register select signal/ Serial data signal
19	RD	MCU read signal
20	GND	Ground
21	GND	Ground
22~37	DB0~DB15	Data bus signal
38~39	GND	Ground



3. 各参数极限值 (ABSOLUTE MAXIMUM RATINGS)

参数 (Parameter)	符号 (Symbol)	最小值(MIN)	典型值(TYP)	最大值(MAX)	单位 (Unit)
操作温度 (Operation temperature)	TOP	-20	-	70	℃
存储温度(Storage temperature)	TST	-30	-	80	℃

4. 电气特性 (ELECTRICAL CHARACTERISTICS)

参数 (Parameter)	符号 (Symbol)	最小值 (MIN)	典型值(TYP)	最大值 (MAX)	单位 (Unit)
逻辑电压 (Logic operating voltage)	IOVCC	1.65	1.8	3.3	V
模拟电源电压电压 (Analog operating voltage)	VCI	2.65	2.8	3.3	V
输入高电平电压 (Input voltage "H"level)	VIH	0.7IOVCC	-	IOVCC	V
输入低电平电压 (Input voltage "L"level)	VIL	0	-	0.3IOVCC	V
输出高电平电压 (Output voltage "H"level)	VOH	0.8IOVCC	-	-	V
输出低电平电压 (Output voltage "L"level)	VOL	0	-	0.2IOVCC	V

5. 背光特性 (BACKLIGHT CHARACTERISTICS)

项目 (Item)	符号 (Symbol)	额定值 (Typ)	单位 (Unit)
工作电流 (Working current)	I_{BL}	80	mA



工作电压 (Working voltage)	V_{BL}	3.2	V
模组亮度 (Module brightness)	L	380	CD/M ² (注)
色坐标 (Color coordinates)	$X=0.28\pm 0.02$	$Y=0.027\pm 0.02$	样品为准 (The sample shall prevail)

6. 光学特性 (OPTICAL CHARACTERISTICS)

Color Chromaticity (CIE1931)	White	W_x	+/-0.02	+/-0.02	(0.296)	(1)(4) CF glass
		W_y			(0.325)	
	Red	R_x			(0.647)	
		R_y			(0.329)	
	Green	G_x			(0.279)	
		G_y			(0.550)	
	Blue	B_x			(0.134)	
		B_y			(0.123)	
Viewing Angle	Hor.	Θ_L	CR>10	-	80	Viewing Angle base on using Normal Polarizer · Reference Only
		Θ_R			80	
	Ver.	Θ_U			80	
		Θ_D			80	
Optima View Direction	ALL					(5)

Note (1) Definition of Viewing Angle:

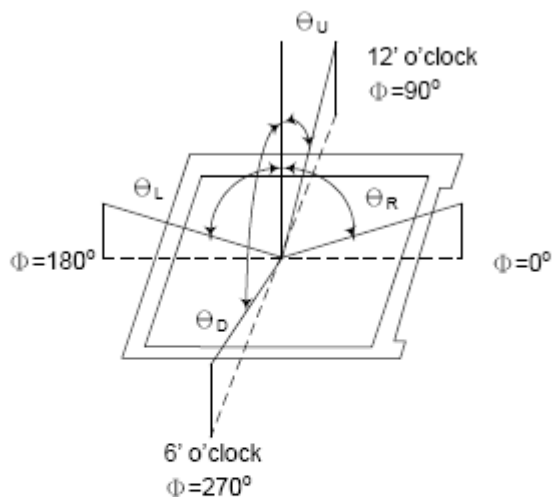

Note (2) Definition of Contrast Ratio (CR):
measured at the center point of panel

$$CR = \frac{\text{Luminance with all pixels white}}{\text{Luminance with all pixels black}}$$



Note (3) Definition of Response Time: Sum of T_R and T_F

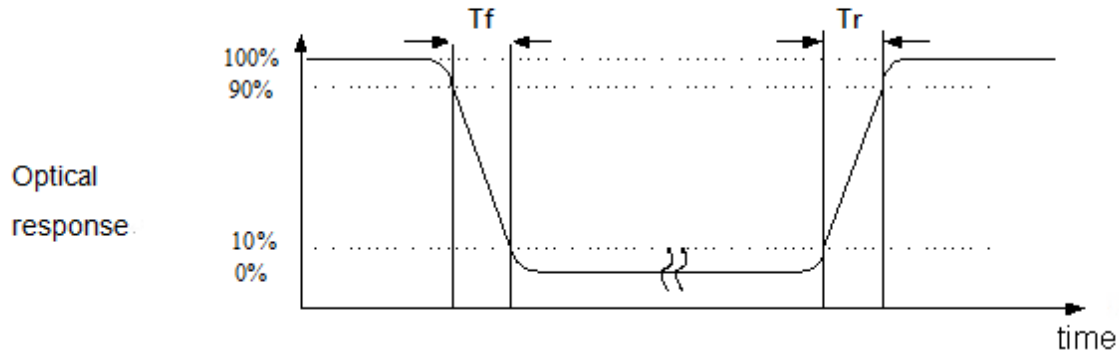

Note (4) Definition of optical measurement setup

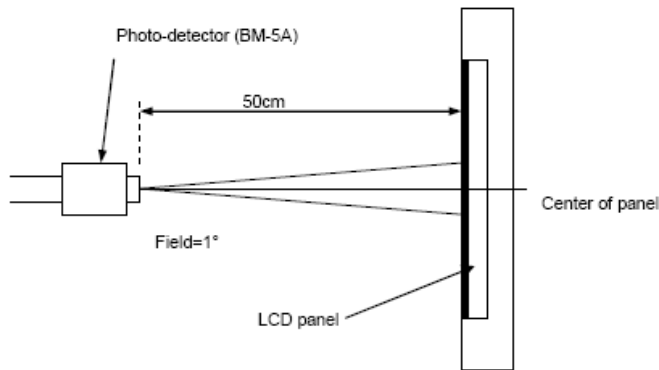

Note (5) Rubbing Direction (The different Rubbing Direction will cause the different optima view direction.)

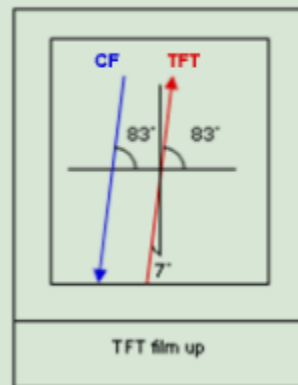



7. 机构图 (MODULE OUTLINE DRAWING)

客户签名:

日期:

已确认此版本的所有图纸

REV	DESCRIPTION	DATE
1.0	首次发行	2021-2-22

KINGTECH

PIN	PIN NAME	PIN	PIN NAME
1	GND	26	D4
2	GND	27	D5
3	LEDK	28	D6
4	LEDK	29	D7
5	LEDA	30	D8
6	LEDA	31	D9
7	GND	32	D10
8	GND	33	D11
9	VCC	34	D12
10	VCC	35	D13
11	IOVCC	36	D14
12	IOVCC	37	D15
13	GND	38	GND
14	GND	39	GND
15	RESET		
16	CS		
17	RS		
18	WR		
19	RD		
20	GND		
21	GND		
22	D0		
23	D1		
24	D2		
25	D3		

NOTES:

1. Display type: IPS
2. Viewing direction: ALL
3. Drive IC: ST7289V
4. Backlight color: 4 LED WHITE 350cd/m²
5. Operation temperature: -20~70° C
6. Storage temperature: -30~80° C
7. LCM Operating Voltage: Vdd=2.8V/10VDD=1.8V
8. Vmids: 模块可视区域, 建议外壳可视区域比Vmids单边小0.3以上

背光电路图

标题: ASSEMBLY **DO NOT SCALE THIS DRAWING. GENERAL TOLERANCE: ±0.2**

PART NO.: PV02819HZ39L

DRAWN BY:	DATE:	PROJECTION:	UNITS: mm
CHECKED BY:	DATE:	SCALE: N.T.S	
APPROVED BY:	DATE:	SHEET: 1 OF 1	

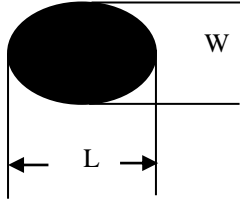
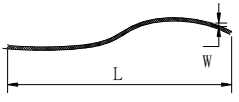
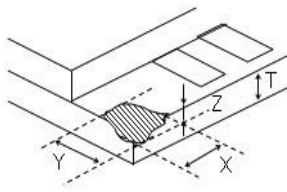
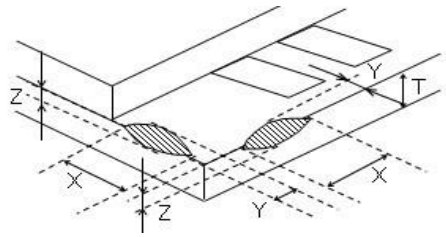
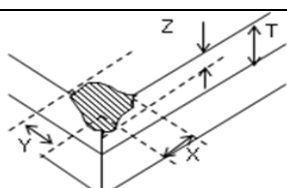

8. LCM 品质检验标准 (INSPECTION SPECIFICATIONS)

不良项目	判定标准				缺点区分	
点状缺陷	$D = (L+W)/2$ 单位: mm 点不良间距需 $\geq 10\text{mm}$ 	尺寸		允许个数	次缺 (检测 RGB 画面 (红、绿、蓝) 点状之间距离不少于 10MM)	
		$D \leq 0.10$		忽略不计		
		$0.10 < D \leq 0.15$		2		
		$0.15 < D \leq 0.2$		1		
		$D > 0.2$		0		
亮点	1. 单一点: 单个 Pixel 2. 连续点: 相连 2 个 Pixel 3. 亮点及暗点总个数不可超过 5 个 4. 点不良间距需 $\geq 10\text{mm}$	单一点		2	次缺 (两个缺陷之间距离不少于 10mm)	
暗点		2 连续亮点		1		
		单一点		5		
		2 连续暗点		1		
Mura	斑点、不均		参照 LCD 原厂判定标准, 用 ND:5%		次缺	
线状缺陷	L: 长度 W: 宽度 线不良间距需 $\geq 10.0\text{mm}$ 	尺寸		允许个数	次缺	
		$W \leq 0.02$		忽略不计		
		$L \leq 2.0, 0.03 < W \leq 0.05$		2		
		$W > 0.05$		依点状缺陷判定		
LCD 角破损 (端子位)		长度 X	宽度 Y	高度 Z	允许数	次缺
		$X \leq 2.0$	$Y \leq 2.0$	$Z \leq T$	2	
		$2.0 < X \leq 3.0$	$2.0 < Y \leq 3.0$	$Z \leq T$	1	
		$X > 3$	$Y > 3$	$Z \leq T$	0	
LCD 边破损 (端子位)		1. 长度 $X \leq 5.0$ 宽度 $Y \leq 1.0$ 2. 崩裂位置不可伤及 ITO 线路、不可影响 bonding				轻缺
LCD 角破损 (非端子部)		长度 X	宽度 Y	高度 Z	允许数	轻缺
		$X \leq 2.0$	$Y \leq 2.0$	不计	2	
		$2.0 < X \leq 3.0$	$2.0 < Y \leq 3.0$	不计	1	

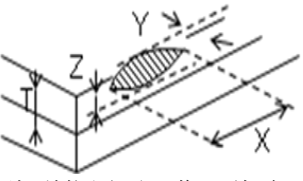
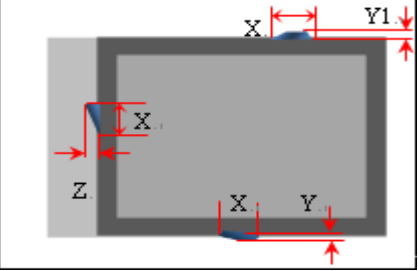
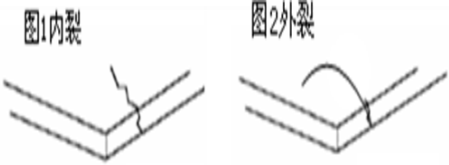

	崩裂位置不可伤及线路	$X > 3$	$Y > 3$		0	
LCD 边破损 (非端子部)	 <p>崩裂位置不可伤及线路</p>	长度 X	宽度 Y	高度 Z	允许数	轻缺
		$X \leq 7.0$	$Y \leq 0.5$	$Z \leq T/2$	2	
		$X \leq 7.0$	$0.5 < Y \leq 0.8$	$Z \leq T$	1	
		$X > 7.0$	$Y > 0.8$		0	
玻璃突出		1. Y、Y1、Z 均 ≤ 0.2 且 $Y+Y1 \leq 0.2$ 时 X 长度不计 2. Y、Y1、Z > 0.2 或 $Y+Y1 > 0.2$ 时，不允许			轻缺	
LCD 裂纹		1: 内裂发生不可。 2: 外裂修正以玻璃破损规格判定, 但不能有可清除的玻璃屑附着。			重缺	
外观检查	CF 偏光片保护膜上划线不可有、气泡不可有、盖章不可有 (依客户特殊要求)				轻缺	

Note;The rest of the test items according to our standards

注：其余测试项按我司标准执行



9. 可靠性测试条件 (RELIABILITY TEST CONDITIONS)

NO. 序号	Test Item 实验项目	Test Condition 实验条件	Inspection after test 实验后检查
1	High Temperature Storage 高温存储测试	80°C±2°C/48 hours	Inspection after 2~4 hours storage at room temperature ,the sample shall be free from defects:实验结束后, 已测试的 LCD 样品必须在室内正常温湿度环境下放置, 2~4 小时以上才能进行功能和外观检查, 样品不允许有以下缺陷: 1.Air bubble in the LCD;模块中有气泡 2.Sealleak;封口松脱 3.Non-display;不显示 4.missing segments;漏笔 5.Glass crack;玻璃破碎 6.Current IDD is twice higher than initial value. 电流 IDD 大于初始值的两倍。
2	Low Temperature Storage 低温存储测试	-30°C±2°C/48 hours	
3	High Temperature Operating 高温操作测试	70°C±2°C 48 hours	
4	Low Temperature Operating 低温操作测试	-20°C±2°C/48 hours	
5	Temperature Cycle 冷热循环存储	-20°C±2°C~25°C~70°C±2°C*10cycles (30min.) (5min.) (30min.)	



6	ESD Test 防静电性测试	<p>Look and function test the samples prior to testing, with air discharge, to a single discharge of TP, nine points every bit of discharge time, every time interval or 5 s, 9 points for a cycle. Put some voltage: plus or minus 8 kv, check each cycle after the discharge, if qualified for the next cycle test, if not qualified, stop test, and problem determination</p> <p>测试前对样品进行外观和功能测试, 采用空气放电, 对 TP 进行单次放电, 9 个点每一点放电一次, 每次间隔$\geq 5s$, 9 个点为一个循环。放点电压: $\pm 8KV$, 每一个循环放电后进行检查, 如果合格就进行下一循环测试, 如果不合格, 试验停止, 并进行问题判定</p>	<p>Test sample electrical function is normal</p> <p>试验样品电气功能正常</p>
---	--------------------	--	--

10. 包装方式 (PACKING MODE)

1 包装规范

- 1.1 装箱办法见《包装方法示意图》。装箱数量则由每一个吸塑盘所装的数量决定。每箱装一叠吸塑, 每叠 11 个吸塑盘, 上面一个吸塑盘不装产品, 交叉层叠放置, 上下需用纸板、胶纸固定。
- 1.2 小箱: 材料为 K3K, 外腔尺寸为 485*355*130mm。
- 1.3 吸塑盘: PET 透防静电或着 PS 黑防静电材料, 厚度为 0.6MIN, 外形尺寸 (根据背光供应商提供吸塑盘尺寸为准), 用量为每箱 11Pcs。
- 1.4 纸板: 材料为 A-A 瓦楞纸板, 用量为每箱 2Pcs。
- 1.5 装箱数量的计算:
 每个吸塑盒所装数量*10 (层)
 每个吸塑盘装产品数量 12, 每箱的装箱数量为: $12*10=120$ (Pcs) 产品。
 小箱包装示意图:

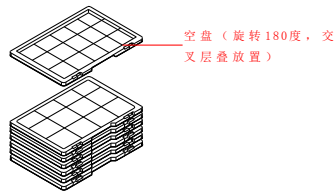

步骤一

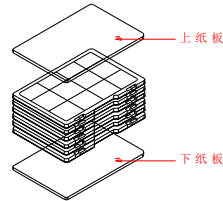

步骤二

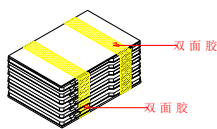

步骤三

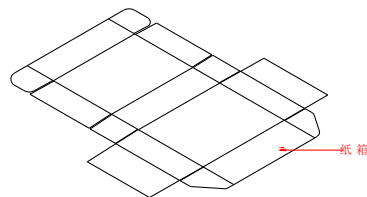

步骤四

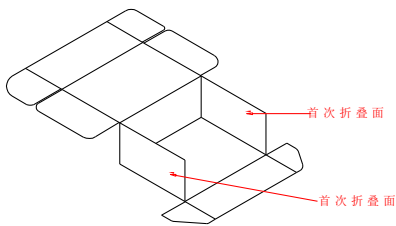

步骤五

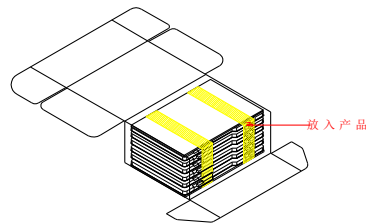

步骤六

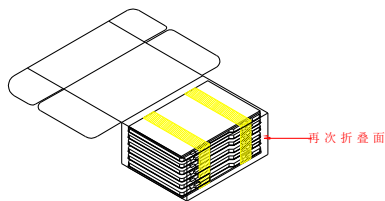

步骤七

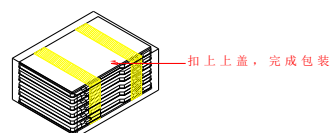

步骤八

2 按产品型号及物料编号贴上标签及盖上 PASS 章

正常情况下,使用统一的标签。部分产品有写上客户的型号或物料编号按“产品型号及客户物料对应表”进行填写。特殊专用的产品标签及出港或走快递的产品,包装标签按跟单人员提供的进行标明。

3 出港及走快递的产品,需要外箱

出港及走快递的产品建议用大小箱包装,即两个小箱加外箱。(如图)

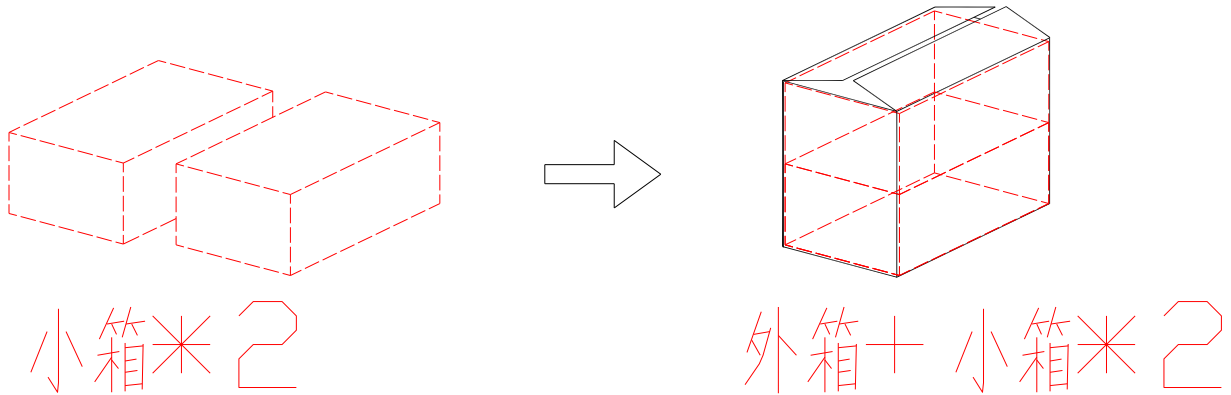

NO.	Item	Dimensions	Quantity	Remark
1	TRAY	One tray	12	
2	SMALL CARTON	One carton/11 tray	120	
3	LARGE CARTON	One carton/2 small carton	240	

4 打包作业流程图

