



PRODUCT SPECIFICATION

- Tentative Specification
- Preliminary Specification
- Approval Specification

SUPPLIER	Kingtech Group Co.,Ltd.
Modle No.	PV02701S0730C

ITEM	BUYER SIGNATURE	DATE
_____	_____	_____
_____	_____	_____
_____	_____	_____

ITEM	SUPPLIER SIGNATURE	DATE
Prepared	_____	_____
Reviewed	_____	_____
Approved	_____	_____



Contents

1. General Description	4
1.1 Product Features	4
1.2 Overview	4
1.3 General Information	4
1.4 Block Diagram	5
2. Absolute Maximum Ratings	6
2.1 Absolute Maximum Ratings (T_A = 25 ± 2 °C)	6
2.2 Environment Requirement (Based on CSOT Module SG2701B01-D)	6
2.3 Absolute Ratings of Environment (Open Cell)	6
3. Electrical Specification	7
3.1 Open Cell Power Consumption (T_A = 25 ± 2 °C)	7
3.2 LVDS Characteristics	8
3.3 Temperature Specifications	9
3.4 Driver IC ESD Specifications	9
4. Input Terminal Pin Assignment	10
4.1 Interface Pin Assignment	10
4.2 Block Diagram of Interface	11
4.3 LVDS Interface	12
4.3.1 VESA Format (Default by code)	12
5. Interface Timing	13
5.1 Timing Table (DE Only Mode)	13
5.2 Power On/Off Sequence	16
6. Optical Characteristics	18
6.1 Measurement Conditions	18
6.2 Optical Specifications	19
7. Mechanical Characteristics	22
7.1 Mechanical Specification	22
9. Precautions	23
9.1 Assembly and Handling Precautions	23
9.2 Safety Precautions	23



Revision History

Version	Date	Page (New)	Section	Description	Revision by
Ver. 0.1	19.05.2020	All	All	Initial release	Danyan Wan
Ver.2.1	16.10.2020	P4,P7,P19	Electrical and Optical Specification	Update the data of Electrical and Optical specification	Danyan Wan



1. General Description

1.1 Product Features

- **FHD Resolution (1920 x 1080)**
- **High Contrast Ratio: 4000:1**
- **High Color Saturation: 72% NTSC**
- **Ultra Wide Viewing Angle: 178° (H)/178° (V) (CR ≥ 10)**
- **DE (Data Enable) Mode**
- **LVDS (Low Voltage Differential Signaling) Interface**

1.2 Overview

PV02701S0730C is a diagonal 27" color active matrix LCD open cell with 2ch-LVDS interface. This open cell is a transmissive type display operating in the normally black mode. It supports 1920 x 1080 FHD resolution and can display up to 16.7M colors (8-bit). Each pixel is divided into Red, Green and Blue sub-pixels which are arranged in horizontal stripe. There is no backlight built-in.

This open cell dedicates for LCD monitor products and provides excellent performance which includes high transmittance, ultra wide viewing angle and high color depth. CSOT open cell comply with RoHS for identification.

1.3 General Information

Item	Specification	Unit	Note
Active Area	597.888 (H) × 336.312 (V)	mm	
Cell Size	630 (H) × 368.2 (V) × 13 (D)	mm	Without side sealing
Weight	TBD	kg	Typ.
Driving Scheme	a-Si TFT Active Matrix	-	
Number of Pixels	1920 × 1080	pixel	
Pixel Pitch(Sub Pixel)	0.1038 (H) × 0.3114(V)	mm	
Pixel Arrangement	RGB Vertical Stripe	-	
Display Colors	16.7 M	color	8-bit
Display Mode	VA Transmissive Mode, Normally Black	-	
Glass thickness (Array / CF)	0.4/ 0.4	mm	
Color Chromaticity	W (0.286,0.306) R (0.640,0.335) G (0.306,0.619) B (0.151,0.054)	-	Typical value measured with CSOT's Flat Backlight at refresh rate $F_R = 60\text{Hz}$.
Contrast Ratio	4000:1 (Typ.)	-	
View Angle (CR>10)	+ 89 / - 89 (H), + 89 / - 89 (V) (Typ.)	-	Typical value measured with CSOT's Flat Backlight
Polarizer (CF side)	Haze 25%, Hard Coating (3H)	-	



1.4 Block Diagram

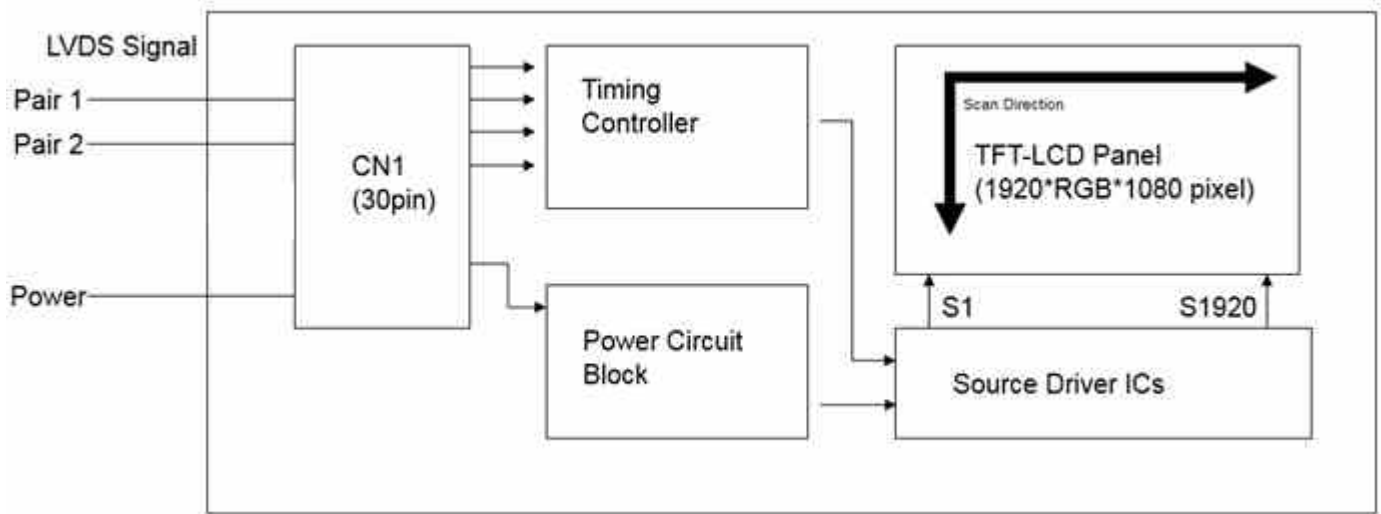



2. Absolute Maximum Ratings

2.1 Absolute Maximum Ratings ($T_A = 25 \pm 2 \text{ }^\circ\text{C}$)

The followings are maximum values which, if exceeded, may cause damage to the unit.

Item	Symbol	Value		Unit
		Min.	Max.	
Power Supply Voltage	V_{CC}	-0.3	13.8	V
Input Signal Voltage	V_{IN}	-0.3	3.6	V

2.2 Environment Requirement (Based on CSOT module SG2701B01-D)

(1) Temperature and relative humidity range are shown as below.

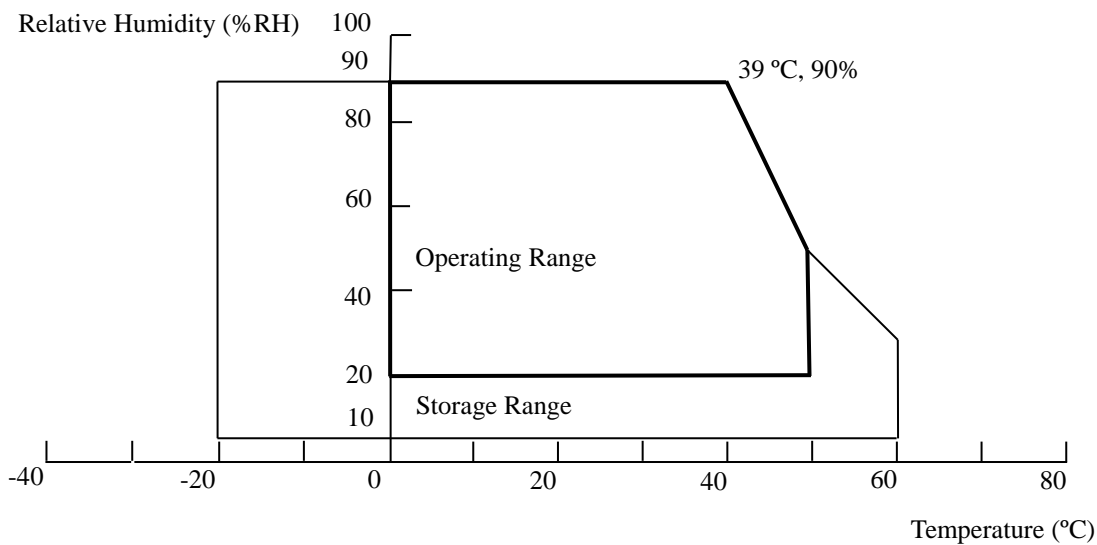

Fig. 2.1 Operating and storage environment

- (a) 90%RH maximum ($T_A < 39 \text{ }^\circ\text{C}$).
- (b) Wet-bulb temperature should be 39 $^\circ\text{C}$ maximum ($T_A > 39 \text{ }^\circ\text{C}$).
- (c) No condensation.

(2) The storage temperature is between - 20 $^\circ\text{C}$ to 60 $^\circ\text{C}$, and the operating ambient temperature is between 0 $^\circ\text{C}$ to 50 $^\circ\text{C}$.

The maximum operating temperature is based on the test condition that the surface temperature of display area is less than or equal to 65 $^\circ\text{C}$ with LCD module in a temperature controlled chamber alone. Thermal management should be considered in final product design to prevent the surface temperature of display area from being over 65 $^\circ\text{C}$. The range of operating temperature may degrade in case of improper thermal management in the end product design.

(3) The rating of environment is based on LCD module. Leave LCD cell alone, this environment condition can't be guaranteed.

Except LCD cell, the customer has to consider the ability of other parts of LCD module and LCD module process.

2.3 Absolute Ratings of Environment (Open Cell)

When storing open cell as spares for a long time, please follow the precaution instructions:

- (1) Do not store the open cell in high temperature and high humidity for a long time. It is highly recommended to store the open cell with temperature from 20 $^\circ\text{C}$ to 30 $^\circ\text{C}$ in normal humidity (50 \pm 10%RH) with shipping package.
- (2) The open cell should be kept within one month shelf life



3. Electrical Specification

3.1 Open Cell Power Consumption (TA = 25 ± 2 °C)

Parameter	Symbol	Value			Unit	Note	
		Min.	Typ.	Max.			
Power Supply Voltage	V _{CC}	10.8	12.0	13.2	V	(1)	
Rush Current	I _{RUSH}	-	-	2.1	A	(2)	
Power Supply Current	White Pattern	I _{CC}	-	0.262	0.288	A	(3) 75Hz
	Horizontal Stripe		-	0.425	0.468	A	
	Black Pattern		-	0.249	0.274	A	
	White Pattern		-	0.246	0.271	A	(3) 60Hz
	Horizontal Stripe		-	0.374	0.411	A	
	Black Pattern		-	0.235	0.259	A	
Power Consumption	Horizontal Stripe	-	-	5.1	5.61	Watt	75Hz
	Horizontal Stripe	-	-	4.488	4.94	Watt	60Hz

Note:

- (1) The ripple voltage should be controlled less than 10% of V_{CC}.
- (2) Measurement condition: V_{CC} rising time = 470 μs.

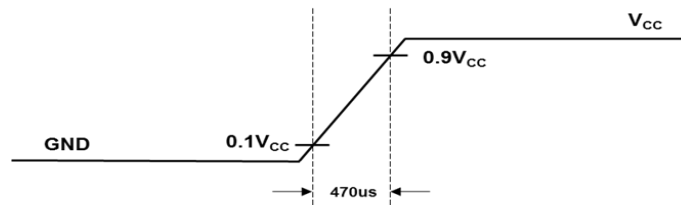
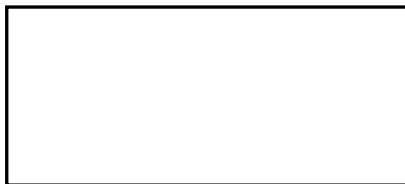

Fig. 3.1 V_{CC} rising time condition

- (3) Measurement condition: V_{CC} = 12 V, Ta = 25 ± 2 °C. The test patterns are shown as below.

A. White Pattern



B. Horizontal Stripe Pattern

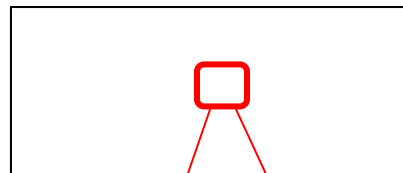

C. Black Pattern

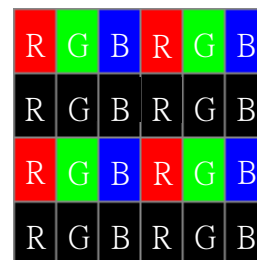

Fig. 3.2 Test patterns



3.2 LVDS Characteristics

Parameter	Symbol	Value			Unit	Note	
		Min.	Typ.	Max.			
LVDS Interface	Differential Input High Threshold Voltage	V_{TH}	+100	-	-	mV	(1) (2)
	Differential Input Low Threshold Voltage	V_{TL}	-	-	-100	mV	
	Common Input Voltage	V_{CM}	1.0	1.2	1.4	V	
	Differential Input Voltage	$ V_{ID} $	100	-	600	mV	
	Terminating Resistor	R_T	87.5	100	112.5	ohm	
CMOS Interface	Input High Threshold Voltage	V_{IH}	2.7	-	3.3	V	
	Input Low Threshold Voltage	V_{IL}	0	-	0.7	V	

Note:

(1) The product should be always operated within above ranges.

(2) The LVDS input signal has been defined as follows:

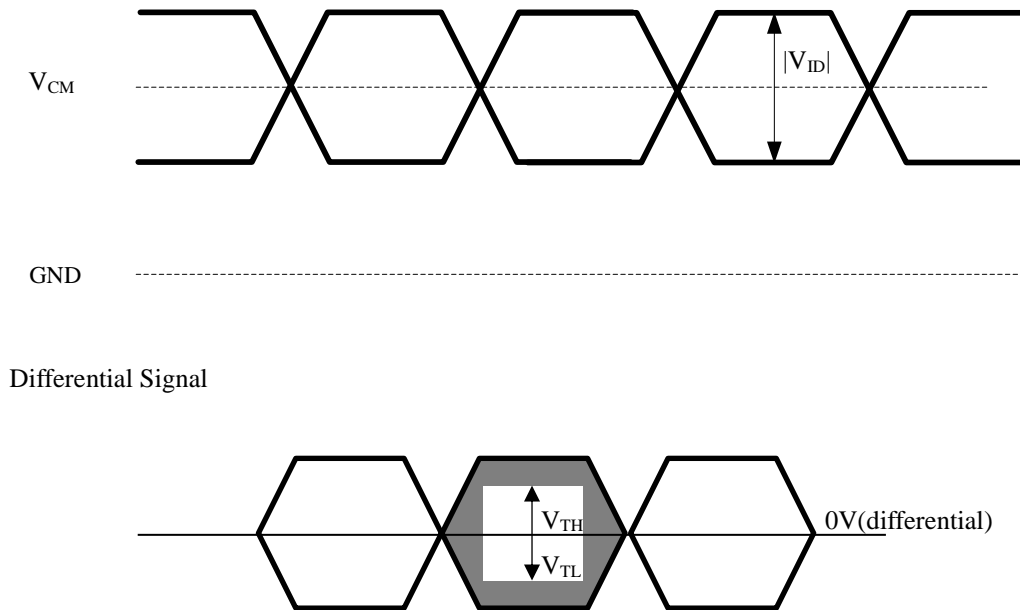

Fig. 3.3 LVDS input signal



3.3 Temperature Specifications

Parameter	Symbol	Specification			Unit	Recommended test pattern	Note
		Min.	Typ.	Max.			
Surface Temperature	T _{TCON}	-	-	105	°C	Horizontal Pattern	(1)
	T _{Driver}	-	-	115		Horizontal Pattern	(1)

Note:

- (1) Any point on the IC surface must be less than Max. specification under any conditions, if the surface temperature is out of the specification, thermal solutions should be applied to avoid to be damaged.

3.4 Driver IC ESD Specifications

The Electro-Static Discharge tolerance of Source COF IC is $\pm 2KV$ tested by ESD Gun. Especially if the LCD module is designed with the Plastic Bezel, we suggest ESD protection solutions should be applied to avoid to be damaged, as shown in Fig.3.4.

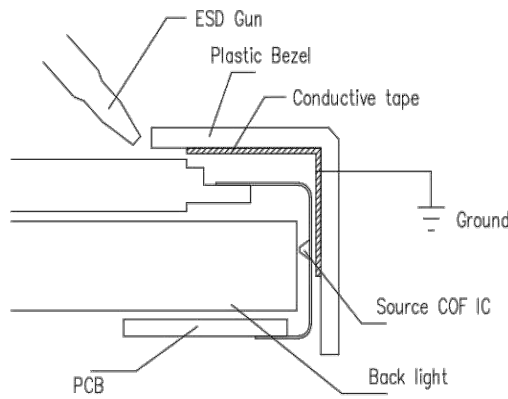

Fig. 3.4 Source COF ESD protection



4. Input Terminal Pin Assignment

4.1 Interface Pin Assignment

CN1: 1-301223-0(XINDAYITONG) or equivalent (Note (1))

NO.	Symbol	Function
1	RX1AN	Negative LVDS differential data output
2	RX1AP	Positive LVDS differential data output
3	RX1BN	Negative LVDS differential data output
4	RX1BP	Positive LVDS differential data output
5	RX1CN	Negative LVDS differential data output
6	RX1CP	Positive LVDS differential data output
7	GND	Ground
8	RX1CLKN	Negative Sampling Clock
9	RX1CLKP	Positive Sampling Clock
10	RX1DN	Negative LVDS differential data output
11	RX1DP	Positive LVDS differential data output
12	RX2AN	Negative LVDS differential data output
13	RX2AP	Positive LVDS differential data output
14	GND	Ground
15	RX2BN	Negative LVDS differential data output
16	RX2BP	Positive LVDS differential data output
17	GND	Ground
18	RX2CN	Negative LVDS differential data output
19	RX2CP	Positive LVDS differential data output
20	RX2CLKN	Negative Sampling Clock
21	RX2CLKP	Positive Sampling Clock
22	RX2DN	Negative LVDS differential data output
23	RX2DP	Positive LVDS differential data output
24	GND	Ground
25	SDA_I	* Reserved for LCD manufacturer's use (SDA)
26	SCL_I	* Reserved for LCD manufacturer's use (SCL)
27	B_INT	* Reserved for LCD manufacturer's use (WPN)
28	PVDD	Input Power Supply : +12V
29	PVDD	
30	PVDD	



Note:

(1)The direction of pin assignment is shown as below:

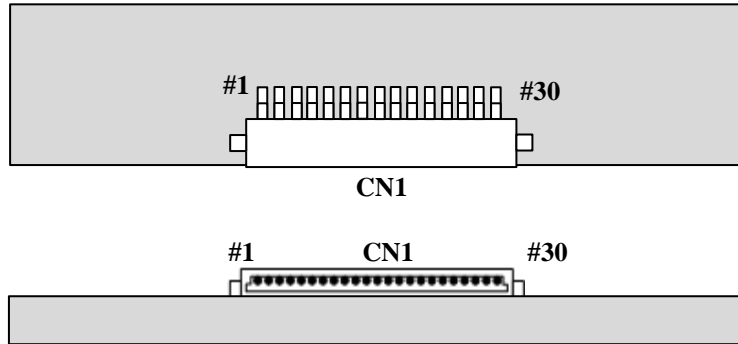

Fig. 4.1 LVDS connector direction sketch map

4.2 Block Diagram of Interface

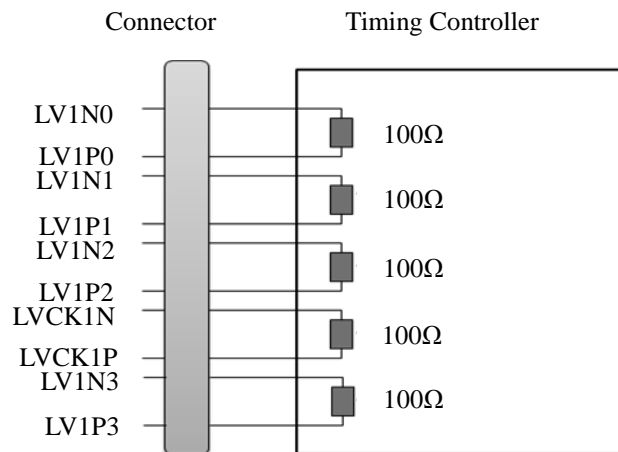

Fig. 4.2 Block diagram of interface

Attention:

- (1) This open cell uses a 100 ohms (Ω) resistor between positive and negative lines of each receiver input.
- (2) LVDS cable impedance shall be 50 ohms per signal line or about 100 ohms per twist-pair line respectively.



4.3 LVDS Interface

4.3.1 VESA Format

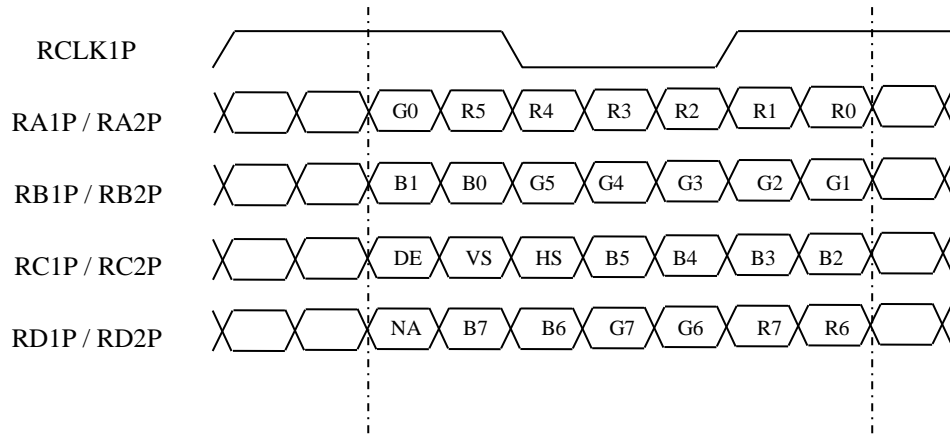

Fig. 4.3 VESA format



5. Interface Timing

5.1 Timing Table (DE Only Mode)

Signal	Item	Symbol	Min.	Typ.	Max.	Unit	Note
LVDS Receiver Clock	Frequency	$F_{clk_{in}}$ ($=1/T_{clk}$)	60	74.25	94	MHz	(1) (2)
	Spread spectrum modulation range	$F_{clk_{in_mod}}$	$F_{clk_{in}}-2\%$	—	$F_{clk_{in}}+2\%$	MHz	(3)
	Spread spectrum modulation frequency	F_{SSM}	10	—	200	KHz	
LVDS Receiver Data	Receiver Skew Margin	T_{RSM}	-380	—	380	ps	(4)
Vertical Active Display Term	Frame Rate	F_R	48	60	75	Hz	
	Total	T_V	1092	1125	1760	T_H	$T_V = T_{VD} + T_{VB}$
	Display	T_{VD}	1080				
	Blank	T_{VB}	12	45	680	T_H	
Horizontal Active Display Term	Total	T_H	1046	1100	1174	T_{CLK}	$T_H = T_{HD} + T_{HB}$
	Display	T_{HD}	960				
	Blank	T_{HB}	86	140	214	T_{CLK}	

Note:

(1) The TFT LCD open cell is operated in DE only mode, H sync and V sync input signal have no effect on normal operation.



(2) $F_{clkin} = T_H \times T_V \times F_R$

T_H , T_V and F_R should operate within the range between Pixel clock frequency Min. and Pixel clock frequency Max..

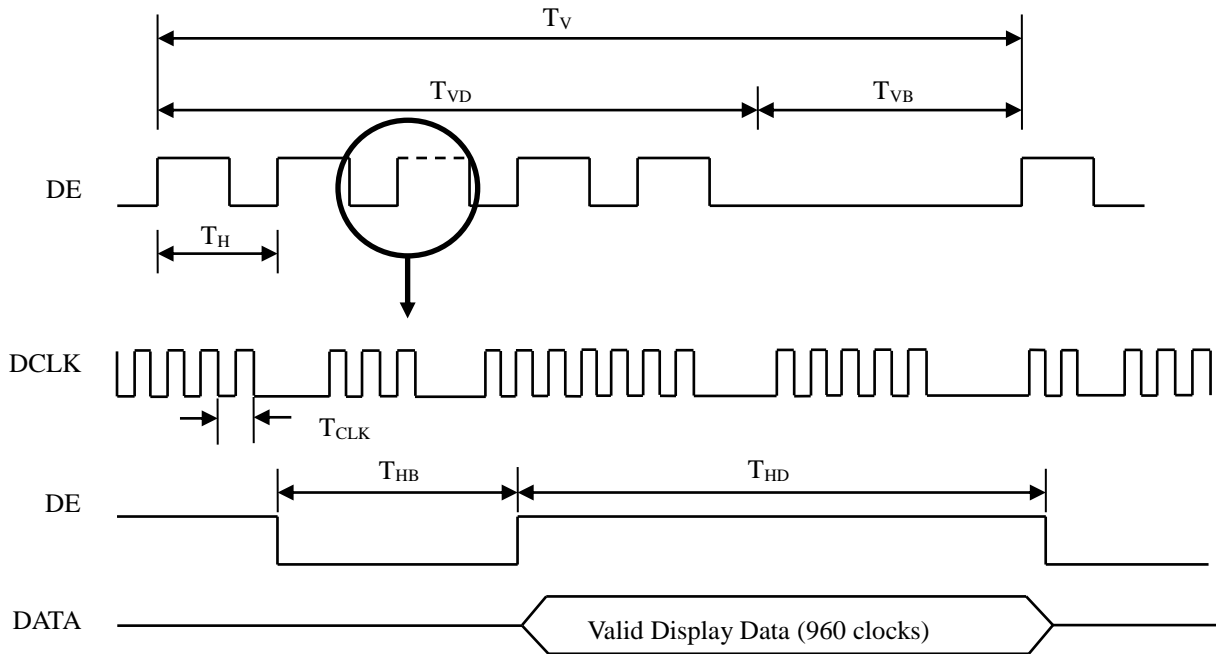

Fig. 5.1 Interface signal timing diagram

(3) The SSM (Spread Spectrum Modulation) is defined as the following figure.

The LVDS SSM's suggestion is disabled by default; SOC board should test all validation if SOC board enables the LVDS SSM.

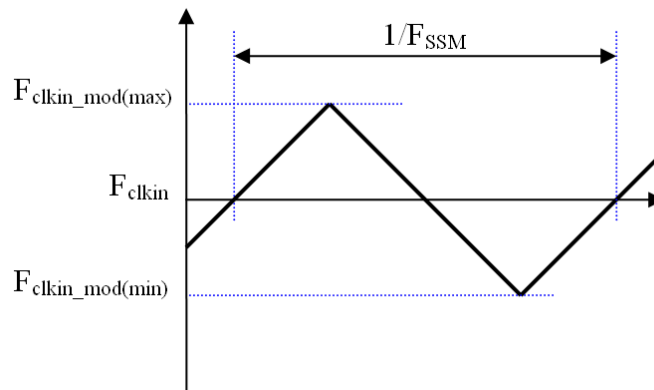

Fig. 5.2 SSM

(4) The LVDS timing diagram and setup/hold time is defined in the following figure.

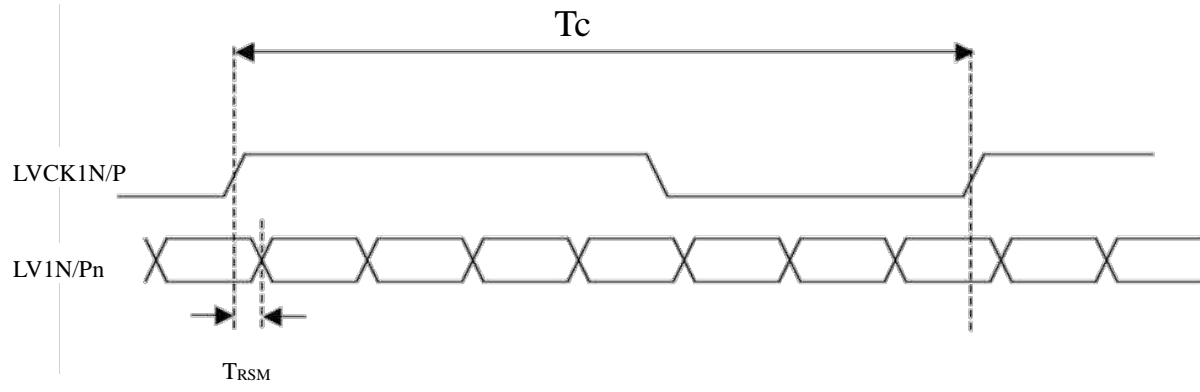

Fig.5.3 LVDS receiver interface timing diagram



5.2 Power On/Off Sequence

To prevent a latch-up or DC operation of the open cell, the power on/off sequence should be as the diagram below.

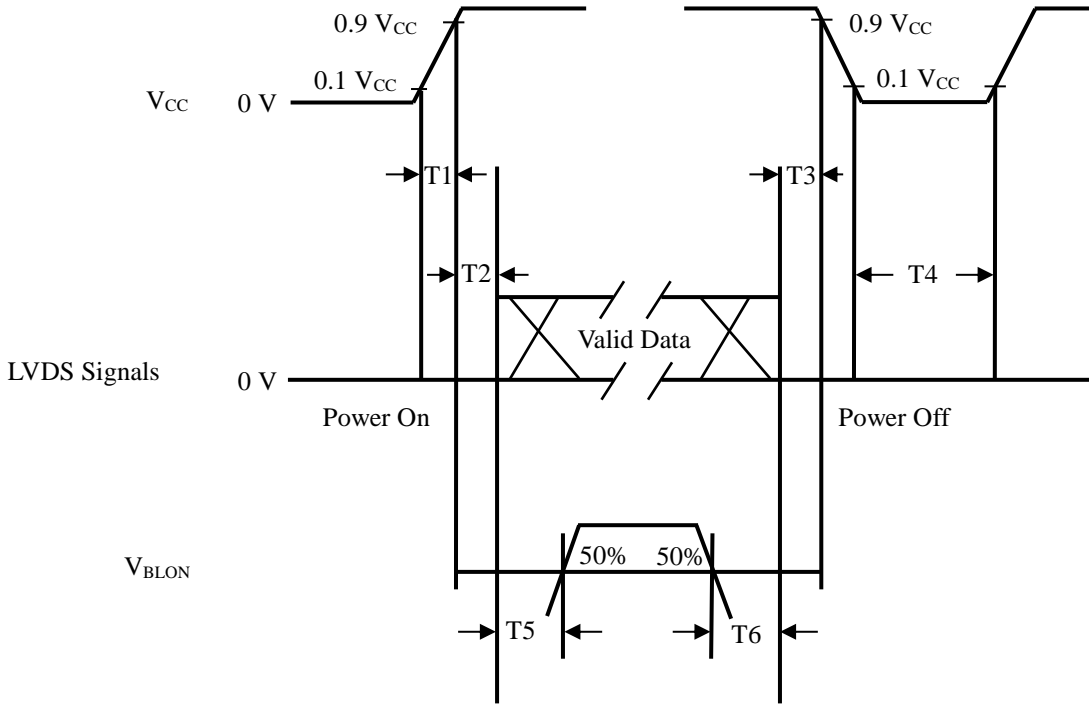

Fig.5.4 Power on/off sequence

Parameter	Values			Unit
	Min.	Typ.	Max.	
T1	0.5	-	10.0	ms
T2	20	-	50	ms
T3	100	-	500	ms
T4	1000.0	-	-	ms
T5	500.0	-	-	ms
T6	100.0	-	-	ms

**Attention:**

- (1) The supplied voltage of the external system for the open cell input should follow the definition of V_{CC} .
- (2) When the backlight turns on before the LCD operation or the LCD turns off before the backlight turns off, the display may momentarily become abnormal screen.
- (3) In case that V_{CC} is in off level, keep the level of input signals on the low or high impedance. If $T2 < 0$, that may cause electrical overstress.
- (4) $T4$ should be measured after the module has been fully discharged between power off and on period.
- (5) Interface signal shall not be kept at high impedance when the power is on.



6. Optical Characteristics

6.1 Measurement Conditions

The table below is the test condition of optical measurement.

Item	Symbol	Value	Unit
Ambient Temperature	T_A	25 ± 2	$^{\circ}\text{C}$
Ambient Humidity	H_A	50 ± 10	% RH
Supply Voltage	V_{CC}	12	V
Driving Signal	Refer to the typical value in Chapter 3: Electrical Specification		
Vertical Refresh Rate	F_R	60	Hz

To avoid abrupt temperature change during optical measurement, it's suggested to warm up the LCD module more than 45 minutes after lighting the backlight and in the windless environment.

To measure the LCD cell, it is suggested to set up the standard measurement system as Fig. 6.1. The measuring area S should contain at least 500 pixels of the LCD cell as illustrated in Fig.6.2 (A means the area allocated to one pixel). In this model, for example, the minimum measuring distance Z is 370 mm when θ is 2 degree. Hence, 500 mm is the typical measuring distance. This measuring condition is referred to 301-2H of VESA FPDM 2.0 about viewing distance, angle, and angular field of view definition.

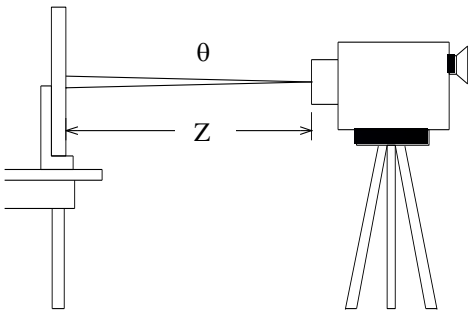

Fig. 6.1 The standard set-up system of measurement

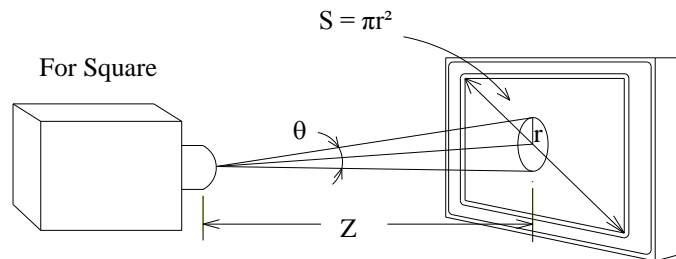

Fig. 6.2 The area S contains at least 500 pixels to be measured.

$$N = \frac{S}{A} \geq 500\text{pixels}$$

N means the actual number of the pixels in the area S .



6.2 Optical Specifications

The table below of optical characteristics is measured by MINOLTA CS2000, MINOLTA CA310, ELDIM OPTI Scope-SA and ELDIM EZ contrast in dark room. (The optical data in the form is measured by matching the backlight of SG2701B01-A.)

Static Contrast Ratio		CR	$\theta H = 0^\circ, \theta V = 0^\circ$ Normal direction	3000	4000	-	-	(1) (2)		
Response Time (With OD)		TL	$\theta H = 0^\circ, \theta V = 0^\circ$ Normal direction	-	8	12	ms	(3)		
Center Transmittance (D65)		T%	$\theta H = 0^\circ, \theta V = 0^\circ$ Normal direction	4.0	4.25	-	%	(2) (4)		
Gamma		--		1.9	2.2	2.5	-	Base on 50~128 gray		
Color Chromaticity (CIE1931)	Red	RX	$\theta H = 0^\circ, \theta V = 0^\circ$ Normal direction at center point. with CSOT's Backlight: SG2701B01-A at refresh rate Fr=60Hz	Typ. - 0.03	0.640	Typ. + 0.03	-	(2) (5)		
		RY								
	Green	GX							0.335	-
		GY							0.306	-
	Blue	BX							0.619	-
		BY							0.151	-
	White	WX							0.054	-
		WY							0.286	-
Color Gamut	CG	-	72%	-	NTSC					
Viewing Angle	Horizontal	$\theta H+$	CR \geq 10	80	89	-	Deg.	(6)		
		$\theta H-$								
	Vertical	$\theta V+$								
		$\theta V-$								

Note:

(1) Definition of static contrast ratio (CR):

It's necessary to switch off all the dynamic and dimming function when measuring the static contrast ratio.

$$\text{Static Contrast Ratio (CR)} = \frac{\text{CR-W}}{\text{CR-D}}$$

CR-W is the luminance measured by LMD (light-measuring device) at the center point of the LCD module with full-screen displaying white. The standard setup of measurement is illustrated in Fig. 6.3; CR-D is the luminance measured by LMD at the center point of the LCD module with full-screen displaying black. The LMD in this item is CS2000.

(2) The LMD in the item could be a spectroradiometer such as (KONICA MINOLTA) CS2000, CS1000(TOPCON), SR-UL2 or the same level spectroradiometer. Other display color analyzer (KONICA MINOLTA) CA210, CA310 or (TOPCON) BM-7 could be involved after being calibrated with a spectroradiometer on each stage of a product.

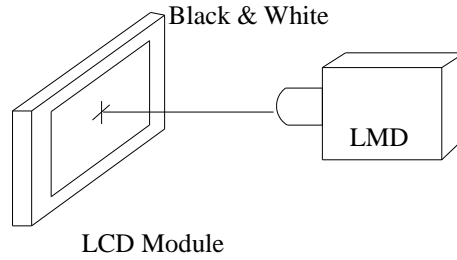

Fig. 6.3 The standard setup of CR measurement

(3) Response time T_L is defined as the average transition time in the response time matrix. The table below is the response time matrix in which each element $t_{X \text{ to } Y}$ is the transition time from luminance ratio X to Y. X and Y are two different luminance ratios among 0%, 25%, 50%, 75%, and 100% luminance. The transition time $t_{X \text{ to } Y}$ is defined as the time taken from 10% to 90% of the luminance difference between X and Y ($X < Y$) as illustrated in Fig.6.4. When $X > Y$, the definition of $t_{X \text{ to } Y}$ is the time taken from 90% to 10% of the luminance difference between X and Y. The response time is optimized on refresh rate $F_r = 60\text{Hz}$.

Measured Transition Time		Luminance Ratio of Previous Frame				
		0%	25%	50%	75%	100%
Luminance Ratio of Current Frame	0%		$t_{25\% \text{ to } 0\%}$	$t_{50\% \text{ to } 0\%}$	$t_{75\% \text{ to } 0\%}$	$t_{100\% \text{ to } 0\%}$
	25%	$t_{0\% \text{ to } 25\%}$		$t_{50\% \text{ to } 25\%}$	$t_{75\% \text{ to } 25\%}$	$t_{100\% \text{ to } 25\%}$
	50%	$t_{0\% \text{ to } 50\%}$	$t_{25\% \text{ to } 50\%}$		$t_{75\% \text{ to } 50\%}$	$t_{100\% \text{ to } 50\%}$
	75%	$t_{0\% \text{ to } 75\%}$	$t_{25\% \text{ to } 75\%}$	$t_{50\% \text{ to } 75\%}$		$t_{100\% \text{ to } 75\%}$
	100%	$t_{0\% \text{ to } 100\%}$	$t_{25\% \text{ to } 100\%}$	$t_{50\% \text{ to } 100\%}$	$t_{75\% \text{ to } 100\%}$	

$t_{X \text{ to } Y}$ means the transition time from luminance ratio X to Y.

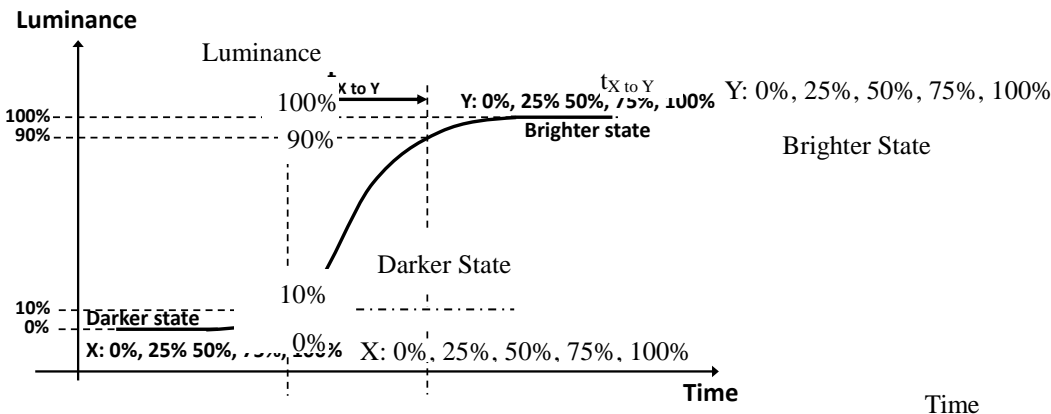

Fig. 6.4 The definition of $t_{X \text{ to } Y}$

All the transition time is measured at the center point of the LCD module by ELDIM OPTI Scope-SA.



(4) Definition of center Transmittance (T%):

The transmittance is measured with full white pattern (Gray 255)

$$\text{Center Transmittance (T\%)} = \frac{\text{Luminance of LCD module}}{\text{Luminance of Backlight}}$$

(5) Definition of color chromaticity:

Each chromaticity coordinates (x, y) are measured in CIE1931 color space when full-screen displaying primary color R, G, B and white. The color gamut is defined as the fraction in percent of the area of the triangle bounded by R, G, B coordinates and the area is defined by NTSC 1953 color standard in the CIE color space. Chromaticity coordinates are measured by CS2000 and the standard setup of measurement is shown in Fig. 6.5.

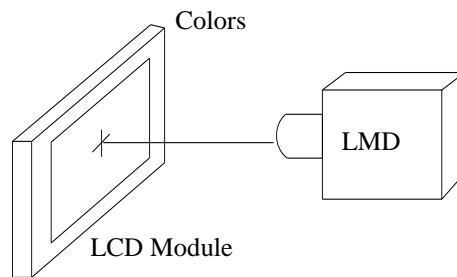

Fig. 6.5 The standard setup of color chromaticity measurement

(6) Definition of viewing angle coordinate system (θ_H , θ_V):

The contrast ratio is measured at the center point of the LCD module. The viewing angles are defined at the angle that the contrast ratio is larger than 10 at four directions relative to the perpendicular direction of the LCD module (two vertical angles: up θ_{V+} and down θ_{V-} ; and two horizontal angles: right θ_{H+} and left θ_{H-}) as illustrated in Fig. 6.6. The contrast ratio is measured by ELDIM EZ Contrast.

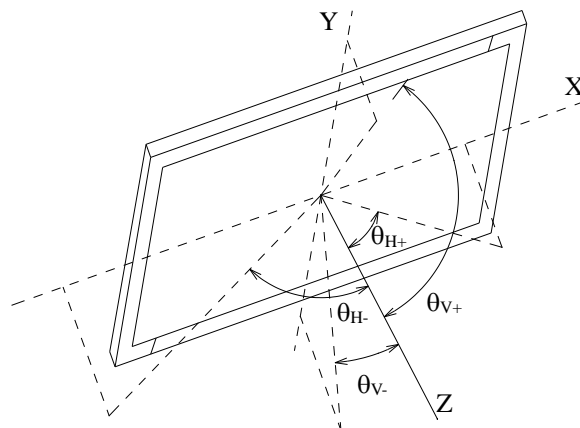

Fig. 6.6 Viewing angle coordination system



7. Mechanical Characteristics

7.1 Mechanical Specification

KINGTECH GROUP CO., LTD.

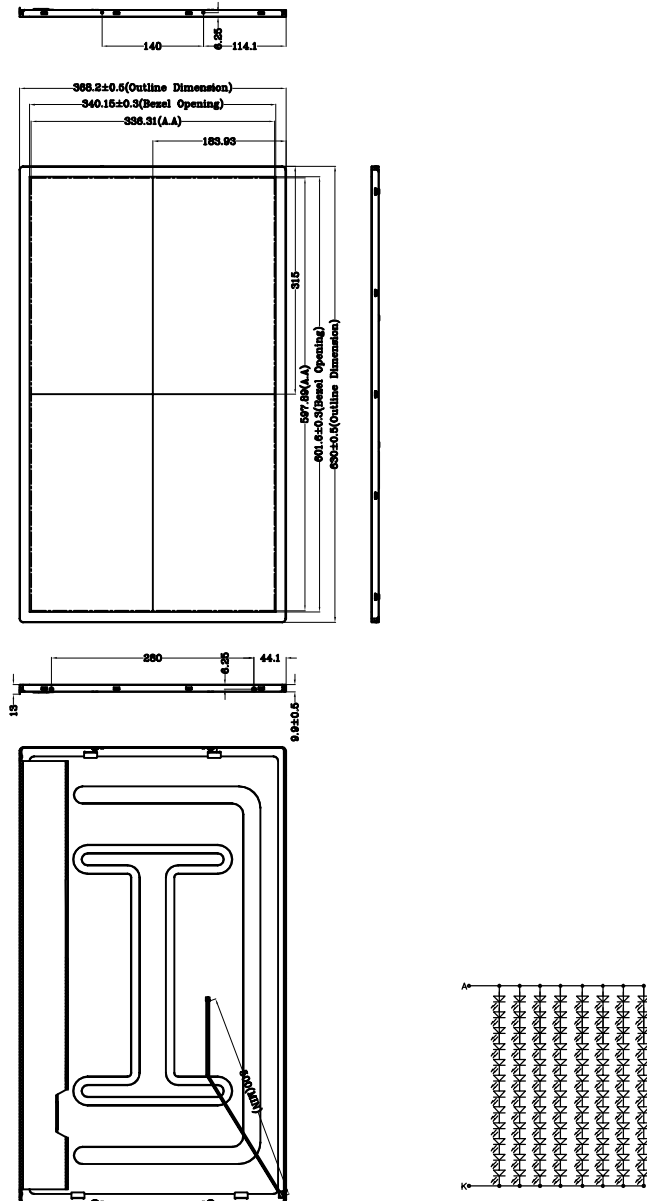

备注：带“☆”为重要尺寸，重点测量，（）内尺寸为参考尺寸，不做测量。

ELECTRICAL/OPRICAL CHARACTERISTICS AT Ta=25°C

PARAMETER	SYMBOL	MIN	TYP	MAX	UNIT	REMARK	
Center Luminous Intensity	Iv □ BLU					IF=500mA, 8※12=96EA	
	Iv ■ LCM	350	400		cd/m ²		
Backlight coordinaies (B/L)	X						
	Y						
LCM coordinaies	X	0.270	0.300	0.330			
	Y	0.320	0.350	0.380			
Forward Voltage	Vf		36		V		
Luminous Tolerance	Iv-m	70	80		%		(min/max) *100

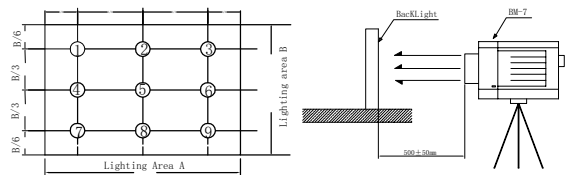

				MODEL NO 产品料号	APPROVED BY 确认	CHECKED BY 审核	DRAWN BY 设计
				PV02701S0730C			
REV	DATE	REVISER	REVISED DESCRIPTIONS	版本: A0			



9. Precautions

9.1 Assembly and Handling Precautions

- (1) The device listed in the product specification sheets was designed and manufactured for monitor application only.
- (2) Do not apply rough force such as bending or twisting to the open cell during assembly.
- (3) It is recommended to assemble or install a open cell into the user's system in clean working areas. The dust and oil may cause electrical short or damage the polarizer.
- (4) Do not apply pressure or impulse to the open cell to prevent the damage to the open cell.
- (5) It is recommended to follow the correct power-on sequence.
- (6) Do not plug in or pull out the interface connector while the open cell is in operation.
- (7) Use soft dry cloth without chemicals for cleaning because the surface of polarizer is very soft and easily be scratched.
- (8) Moisture can easily penetrate into the open cell and may cause the damage during operation.
- (9) High temperature or humidity may deteriorate the performance of the open cell. Please store open cell in the specified storage conditions.
- (10) When ambient temperature is lower than 10 °C, the display quality might be deteriorated. For example, the response time will become slow.

9.2 Safety Precautions

- (1) If the liquid crystal material leaks from the panel, it should be kept away from the eyes or mouth. In case of contact the hands, skin or clothes, it has to be washed away thoroughly with soap.
- (2) After the open cell end of life, it is not harmful in case of norm.