



承认书

产品型号: DW1562B5Z0 (Color gamut: 45%)

产品规格: 1920RGB * 1080 INNO TFT LCM(420cd/m²)

送承方: Kingtech Group Co.,Ltd

制订	审查	核准	公司印章
蒋雨志 2023.07.21		王如林 2023.07.21	

承认方:

研发部	工程部	品质部	核准	公司印章

临时规格书 (10串6并背光)

正式规格书



Index

Contents	Page
1. LCM Specification	4
2. Mechanical Specification.....	5
3. Pin Descriptions.....	6
4. Electrical Units.....	7
5. AC Characteristics.....	10
6. Power On/Off Sequence.....	13
7. Optical Specifications.....	15
8. Reliability Test Items.....	18
9. Handling Precautions.....	19
10. QC.....	20



1. LCM Specification

1.1 Description

DW1562B5Z0 is a transmissive type color active matrix liquid crystal display(LCD) which uses amorphous thin film transistor(TFT) as switching devices. This product is composed of a TFT LCD panel, 4 drives IC, a PCBA and a LED-backlight unit. The active display area is 15.6 inches diagonally measured and the native resolution is 1920*RGB*1080.Features of this product are listed in the following table.

1.2 Functions & Features

Table 1.1 Module Functions & Features

Parameter	Value	Unit
LCD Mode	TFT/Transmissive	-
Color Depth	16.7M	-
Display Resolution	1920RGB*1080	pixels
Module Size	204.98(H)*350.72(W)*2.82(T)(W/O PCB) 204.98(H)*350.72(W)*5.00(T)(WithPCB)	mm
Active Area (A.A)	193.59(H)*344.16(W)	mm
Pixel Arrangement	RGB-stripe	-
Viewing Direction	ALL	
Display Mode	Normally Black	
LCD Controller/Driver	ILI6145A	-
IC Package Type	COG	-
Interface	eDP	-
Power Supply Voltage	3.3 (3.0~3.6V)	V
LCM Brightness	420 (Type.)	cd/m ²
Back-light	White LED*60	PCS
Power consumption (Typ.)	P _D : 0.9	W
	P _{BL} : 3.6	W
	P _{Total} : 4.5	W

Note : The specified power consumption (with converter efficiency) is under the conditions at VCCS = 3.3 V, fv = 60 Hz, and Ta = 25 ± 2 °, whereas **Mosaic** pattern is displayed.



1.3 Function Block Diagram

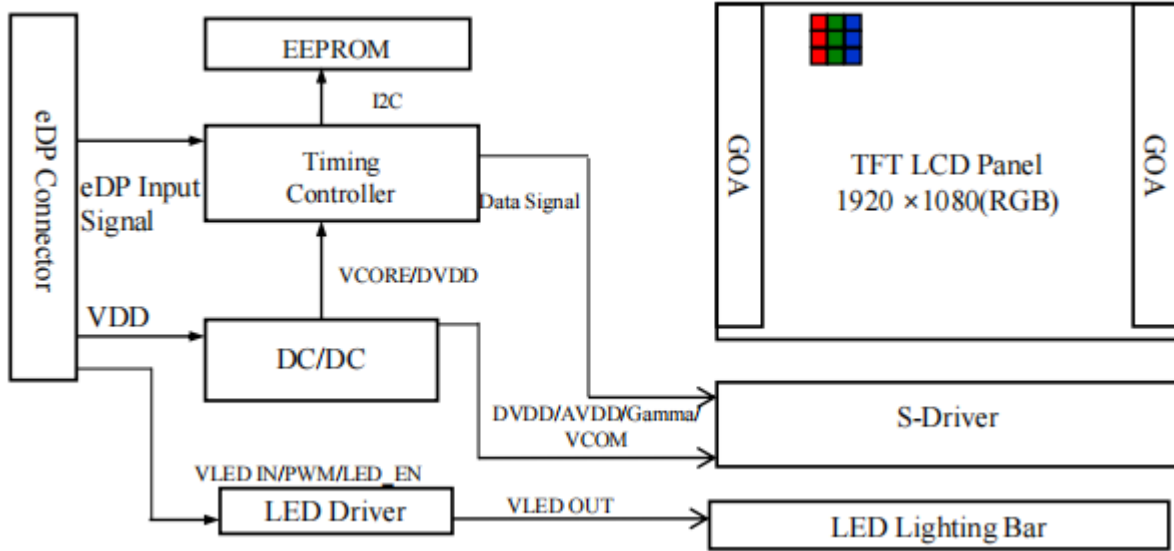



2. Mechanical Specification

RoHS

尺寸 (mm):

- *350.72±0.3 <OUTLINE>
- *346.86±0.3 (UP PDL)
- *344.16±0.2 (A-A)
- 175.36
- 1.93
- 3.28
- 3.12
- 1.97
- 99.92
- *193.59±0.2 <A-A>
- *196.76±0.3 (UP PDL)
- *204.98±0.3 <OUTLINE>

15.6" TFT Imodux
1920*1080*1080
ALL

硬铝铁框

此区域为非镂空铁框区，最大凸起高度为0.10mm

尺寸 (mm):

- 2.82±0.2
- 23.62
- 5.0±0.2
- 0.6 Max.
- 110.26
- 12.78

Pin 1

Pin 2

Pin 3

Pin 4

Pin 5

Pin 6

Pin 7

Pin 8

Pin 9

Pin 10

Pin 11

Pin 12

Pin 13

Pin 14

Pin 15

Pin 16

Pin 17

Pin 18

Pin 19

Pin 20

Pin 21

Pin 22

Pin 23

Pin 24

Pin 25

Pin 26

Pin 27

Pin 28

Pin 29

Pin 30

Backlight LED 10串6并60颗 Circuit

A1 → K1

A2 → K2

→ K3

→ K4

→ K5

→ K6

Kingtech Group Co., Ltd	
TITLE:	DW1562B5Z0
DOC. NO.:	MI56160-237-7101
PART NO.:	10115060010
REV.:	1.0
SHEET:	1 OF 1
SCALE:	1:1
UNITS:	mm

REV.	DESCRIPTION	DATE	APPROVE:	DATE	CHECK:	DRAWN:
1.0	新制订	2023.05.17	王加林			蒋雨吉

NTSC 45 %	
LCM Brightness	370cd/m ² (MIN) 420 cd/m ² (TYP)
Display Type	TFT/NormallyBlack/TRANSMISSIVE
Display Resolution	DDTS:1920RGB*1080
Viewing Angle	ALL
LCD Controller/Driver	ILI16145A / MST7332L
Logic Voltage	3.3V
Operation Temperature	0°C ~ 70°C
Storage Temperature	-30°C ~ 80°C
Backlight Spec.	White LED (10 dies in series 6 parallel I=120mA V=27~33V)



3. Pin Descriptions

3.1 Input CONN Pin Assignment

Input Connector (I-pex 20455-030E-76) is used for the module electronics interface, the recommended CONN of user is 20453-030T-03 manufactured by I-pex.

Pin No.	Symbol	I/O	Functional	Remark
1	NC	I	No Connection.eded	
2	H_GND	P	System ground.	
3	ML1-	I/O	eDP RX channel 1 negative	
4	ML1+	I/O	eDP RX channel 1 positive	
5	H_GND	P	System ground.	
6	ML0-	I/O	eDP RX channel 0 negative	
7	ML0+	I/O	eDP RX channel 0 positive	
8	H_GND	P	System ground.	
9	AUX+	I/O	eDP AUX CH positive	
10	AUX-	I/O	eDP AUX CH negative	
11	H_GND	P	System ground.	
12-13	VCCS_3.3V	P	Power Supply, 3.3V (typ.)	
14	BIST	I	H,BIST pattern; L,Black pattern	
15-16	H_GND	P	System ground.	
17	HPD	O	Hot plug detect output.	
18-21	BL_GND	P	LED Ground	
22	BL_ENABLE	I	BL_Enable Signal of LED Converter	
23	BL_PWM	I	PWM Dimming Control signal of LED converter	
24-25	N.C	P	No Connection.	
26-29	BL_VCCS	P	LED Power supply +, 9V-21V	
30	N.C	I	No Connection.	

3.2 CONN PIN1 Location

Input CONN is on bottom side of PCBA, pin 1 location shows as following figure.

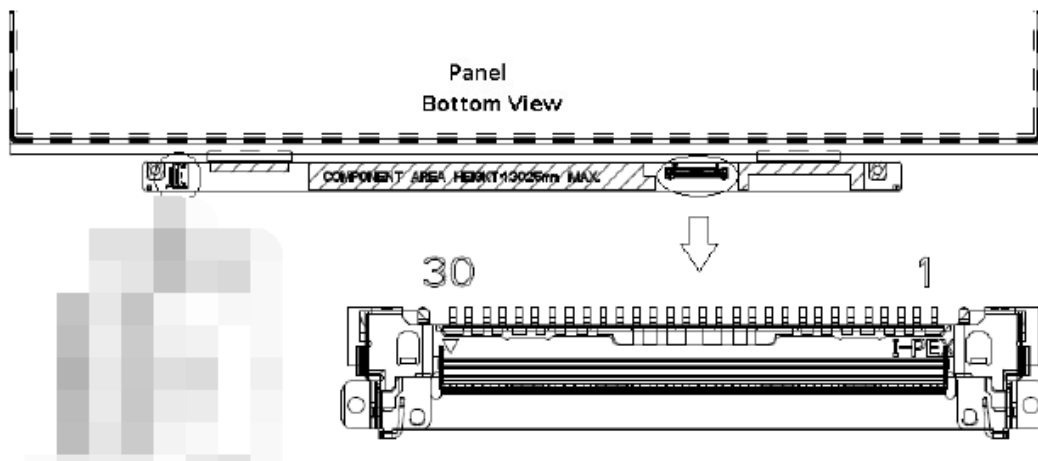



3.3 CTP PIN Descriptions

TBD.

4. Electrical Units

4.1 Absolute Maximum Ratings

The absolute maximum ratings are list on Table 4.1. When used out of the absolute maximum ratings, the LCM may be permanently damaged. Using the LCM within the following electrical characteristics limit is strongly recommended for normal operation. If these electrical characteristic conditions are exceeded during normal operation, the LCM will malfunction and cause poor reliability.

Table 4.1 Module Absolute Maximum Ratings

Item	Symbol	Unit	Value	Note
Power Supply Voltage (1)	Vdd	V	-0.3 to +4.0	
Power Supply Voltage (2)	VGH ~ VSS	V	23.8 to 24.2	
Power Supply Voltage (3)	VSS ~ VGL	V	-9.4 to -9	
Operating Temperature	Top	°C	-0 to +70	
Storage Temperature	Tst	°C	-30 to +80	
Operating Humidity	Hop	%(RH)	10~85	

(VSS=0V)



4.2 LCD Electrical characteristics (Ta=25 C)

Parameter	Symbol	Value			Unit	Note	
		Min.	Typ.	Max.			
Power Supply Voltage	VCCS	3.0	3.3	3.6	V	(1)	
Ripple Voltage	V _{RP}	-	50	150	mV	(1)	
Inrush Current	I _{RUSH}	0	-	1.5	A	(1),(2)	
Power Supply Current	Mosaic	I _{VCCS}	210	240	270	mA	(3)
	Black		190	220	250	mA	(3)
	H 1 line Stripe		450	550	650	mA	
HPD Pull-Low Resistance	R _{HPD}	30K	-	100K	ohm	(4)	
HPD	High Level	V _{HHPD}	2.25	-	2.75	V	(5)
	Low Level	V _{LHPD}	0	-	0.4	V	(5)

Note (1) The ambient temperature is $T_a = 25 \pm 2^\circ$.

Note (2) I_{RUSH}: the maximum current when VCCS is rising

I_{is}: the maximum current of the first 100ms after power-on

Measurement Conditions: Shown as the following figure. Test pattern: black.

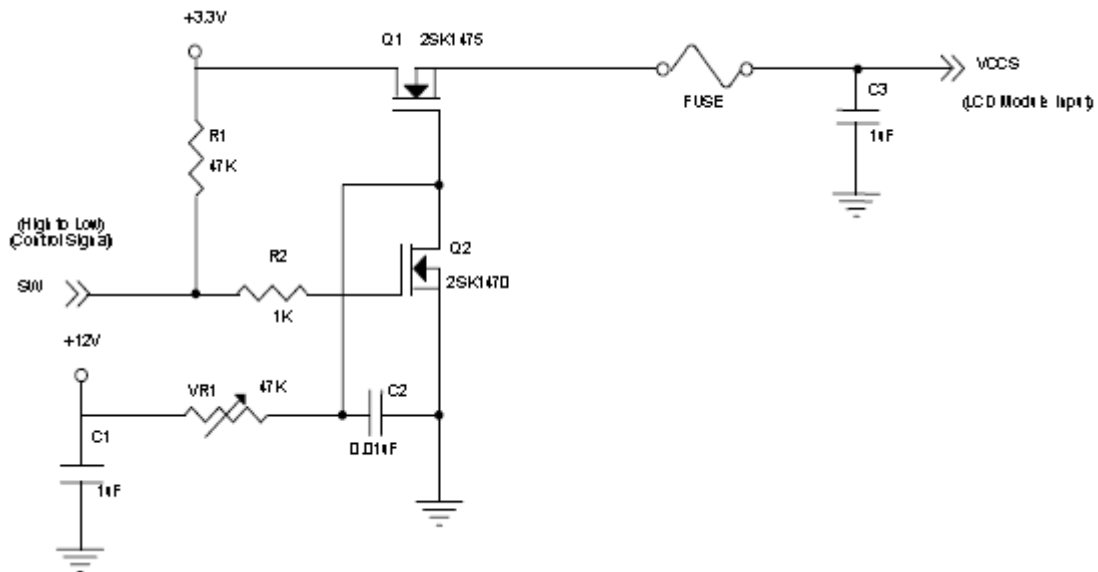



VCCS rising time is 0.5ms

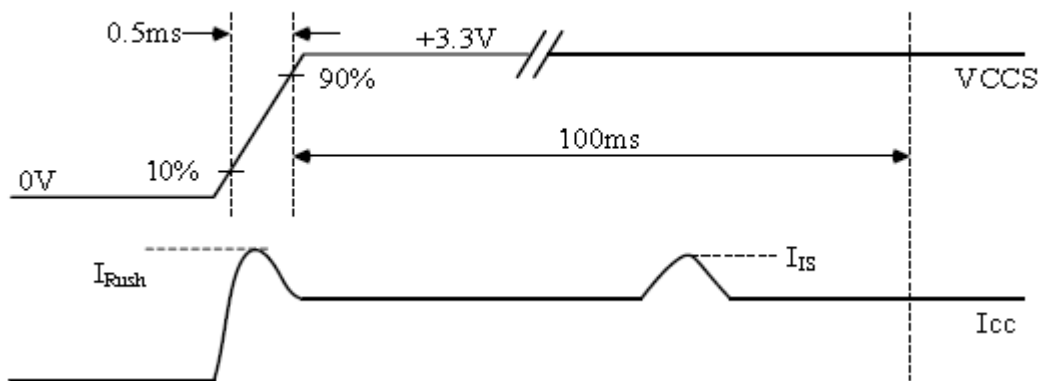

Note (3) The specified power supply current is under the conditions at VCCS = 3.3 V, $T_a = 25 \pm 2^\circ$, DC Current and $f_v = 60$ Hz, whereas a specified power dissipation check mosaic pattern is displayed

Mosaic Pattern

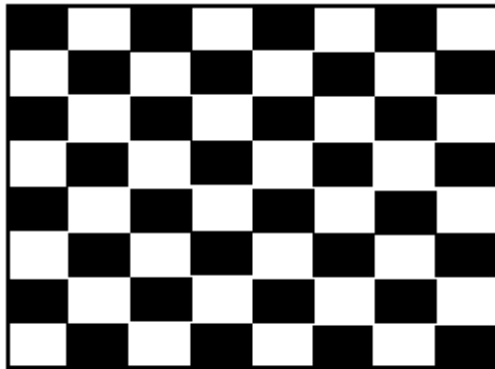

Active Area

Note (4) The specified signals have pull down resistor to ground in the LCD module respectively. Customers should keep the input signal level requirement with the load of LCD module. Please refer to Note (4) of 4.3 Back-light spec to obtain more information.

Note (5) When a source detects a low-going HPD pulse, it must be regarded as a HPD event. Thus, the source must read the link / sink status field or receiver capability field of the DPCD and take corrective action.



4.3 Back-light Specification

Table 4.3 Back-light Characteristics

Item	Symbol	Conditions	Min.	Type.	Max.	Unit
Supply Voltage	VF	Only Backlight	27	30	33	V
Supply Current	IF		120			mA
Average Brightness	IV	Backlight Current IF=120mA	5200	6200	-	Cd/ m ²
CIE Color Coordinate (Without LCD)	X	Backlight Current IF=120mA	0.26	0.29	0.33	-
	Y		0.27	0.31	0.34	
Uniformity	B	Backlight Current IF=120mA	--	75%	-	%
Color	White					

Note: 10 LEDs in series 6 parallel connection.

LCM Brightness: 420cd/m² (Type. Without CTP)

4.4 CTP Specification

Empty.



5. AC Characteristics

5.1 Display Port Interface

Parameter	Symbol	Min.	Typ.	Max.	Unit	Notes
Differential Signal Common Mode Voltage(MainLink and AUX)	VCM	0		2	V	(1)(4)
AUX AC Coupling Capacitor	C_AUX_Source	75		200	nF	(2)
Main Link AC Coupling Capacitor	C_ML_source	75		200	nF	(3)

Note (1) Display port interface related AC coupled signals should follow VESA DisplayPort Standard Version1. Revision 1a and VESA Embedded DisplayPort™ Standard Version 1.2. There are many optional items described in eDP1.2. If some optional item is requested, please contact us.

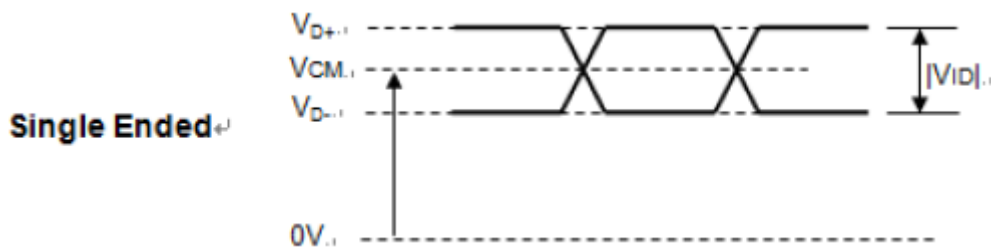

(2) Recommended eDP AUX Channel topology is as below and the AUX AC Coupling Capacitor (C_Aux_Source) should be placed on the source device..

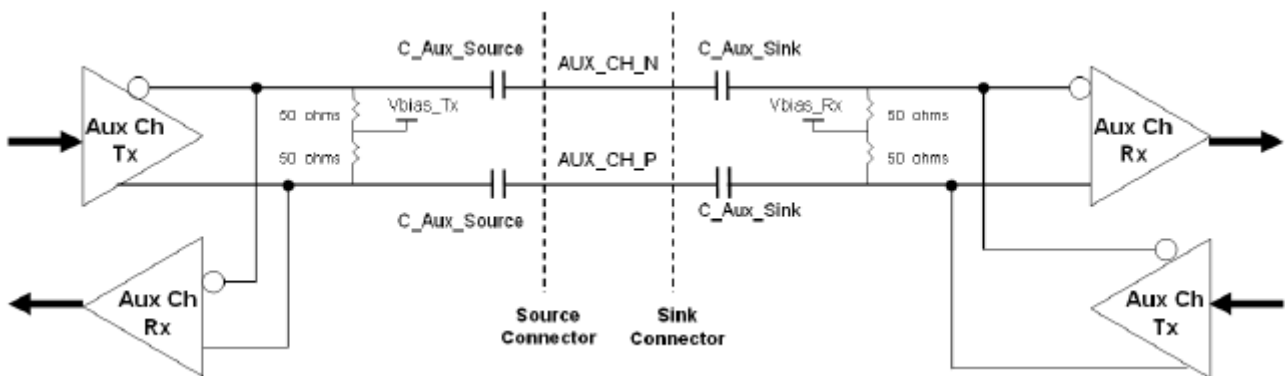

(3) Recommended Main Link Channel topology is as below and the Main Link AC Coupling Capacitor (C_ML_Source) should be placed on the source device.

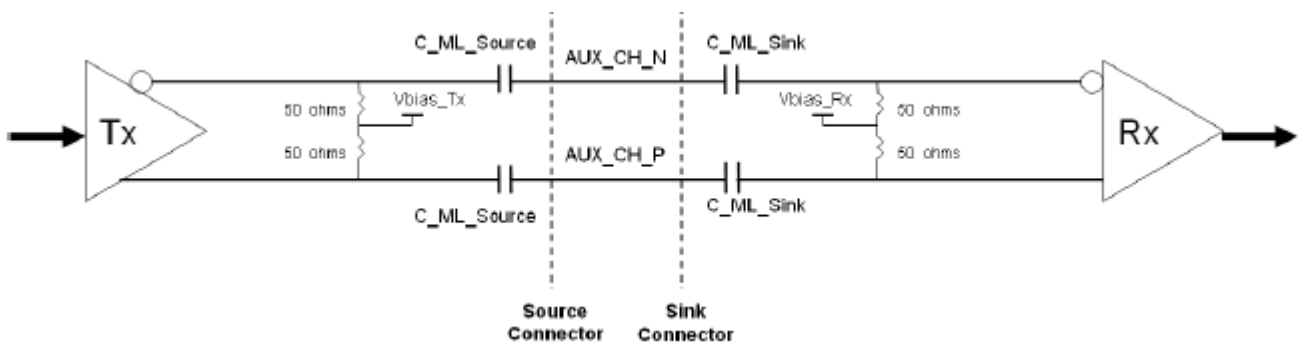

(4) The source device should pass the test criteria described in DisplayPort Compliance Test Specification(CTS) 1.1



5.2 Color Data Input Assignment

Color		Data Signal																						
		Red								Green								Blue						
		R7	R6	R5	R4	R3	R2	R1	R0	G7	G6	G5	G4	G3	G2	G1	G0	B7	B6	B5	B4	B3	B2	B1
Basic Colors	Black	0	0	0	0	0	0	0	0	0	0	0	0	0	0	0	0	0	0	0	0	0	0	0
	Red	1	1	1	1	1	1	1	0	0	0	0	0	0	0	0	0	0	0	0	0	0	0	0
	Green	0	0	0	0	0	0	0	1	1	1	1	1	1	1	1	0	0	0	0	0	0	0	0
	Blue	0	0	0	0	0	0	0	0	0	0	0	0	0	0	0	1	1	1	1	1	1	1	1
	Cyan	0	0	0	0	0	0	0	1	1	1	1	1	1	1	1	1	1	1	1	1	1	1	1
	Magenta	1	1	1	1	1	1	1	0	0	0	0	0	0	0	0	1	1	1	1	1	1	1	1
	Yellow	1	1	1	1	1	1	1	1	1	1	1	1	1	1	1	0	0	0	0	0	0	0	0
	White	1	1	1	1	1	1	1	1	1	1	1	1	1	1	1	1	1	1	1	1	1	1	1
Gray Scale Of Red	Red(0)/Dark	0	0	0	0	0	0	0	0	0	0	0	0	0	0	0	0	0	0	0	0	0	0	
	Red(1)	0	0	0	0	0	0	1	0	0	0	0	0	0	0	0	0	0	0	0	0	0	0	
	Red(2)	0	0	0	0	0	0	1	0	0	0	0	0	0	0	0	0	0	0	0	0	0	0	
	...	:	:	:	:	:	:	:	:	:	:	:	:	:	:	:	:	:	:	:	:	:	:	
	...	:	:	:	:	:	:	:	:	:	:	:	:	:	:	:	:	:	:	:	:	:	:	
	...	:	:	:	:	:	:	:	:	:	:	:	:	:	:	:	:	:	:	:	:	:	:	
	Red(253)	1	1	1	1	1	1	0	1	0	0	0	0	0	0	0	0	0	0	0	0	0	0	
	Red(254)	1	1	1	1	1	1	1	0	0	0	0	0	0	0	0	0	0	0	0	0	0	0	
Red(255)	1	1	1	1	1	1	1	0	0	0	0	0	0	0	0	0	0	0	0	0	0	0		
Gray Scale Of Green	Green(0)/Dark	0	0	0	0	0	0	0	0	0	0	0	0	0	0	0	0	0	0	0	0	0	0	
	Green(1)	0	0	0	0	0	0	0	0	0	0	0	0	0	1	0	0	0	0	0	0	0	0	
	Green(2)	0	0	0	0	0	0	0	0	0	0	0	0	0	1	0	0	0	0	0	0	0	0	
	...	:	:	:	:	:	:	:	:	:	:	:	:	:	:	:	:	:	:	:	:	:	:	
	...	:	:	:	:	:	:	:	:	:	:	:	:	:	:	:	:	:	:	:	:	:	:	
	...	:	:	:	:	:	:	:	:	:	:	:	:	:	:	:	:	:	:	:	:	:	:	
	Green(253)	0	0	0	0	0	0	0	1	1	1	1	1	1	0	1	0	0	0	0	0	0	0	
	Green(254)	0	0	0	0	0	0	0	1	1	1	1	1	1	1	0	0	0	0	0	0	0	0	
Green(255)	0	0	0	0	0	0	0	1	1	1	1	1	1	1	1	0	0	0	0	0	0	0		
Gray Scale Of Blue	Blue(0)/Dark	0	0	0	0	0	0	0	0	0	0	0	0	0	0	0	0	0	0	0	0	0	0	
	Blue(1)	0	0	0	0	0	0	0	0	0	0	0	0	0	0	0	0	0	0	0	0	0	1	
	Blue(2)	0	0	0	0	0	0	0	0	0	0	0	0	0	0	0	0	0	0	0	0	1	0	
	...	:	:	:	:	:	:	:	:	:	:	:	:	:	:	:	:	:	:	:	:	:	:	
	...	:	:	:	:	:	:	:	:	:	:	:	:	:	:	:	:	:	:	:	:	:	:	
	...	:	:	:	:	:	:	:	:	:	:	:	:	:	:	:	:	:	:	:	:	:	:	
	Blue(253)	0	0	0	0	0	0	0	0	0	0	0	0	0	0	1	1	1	1	1	1	1	0	
	Blue(254)	0	0	0	0	0	0	0	0	0	0	0	0	0	0	1	1	1	1	1	1	1	0	
Blue(255)	0	0	0	0	0	0	0	0	0	0	0	0	0	0	1	1	1	1	1	1	1	0		

Note (1) 0: Low Level Voltage, 1: High Level Voltage

5.3 Display Timing Specifications

The input signal timing specifications are shown as the following table and timing diagram.

Refresh rate 60Hz

Signal	Item	Symbol	Min.	Typ.	Max.	Unit	Note
DCLK	Frequency	1/Tc	151.6	152.84	154.04	MHz	-
DE	Vertical Total Time	TV	1128	1132	1136	TH	-
	Vertical Active Display Period	TVD	1080	1080	1080	TH	-
	Vertical Active Blanking Period	TVB	TV-TVD	52	TV-TVD	TH	-
	Horizontal Total Time	TH	2240	2250	2260	Tc	-
	Horizontal Active Display Period	THD	1920	1920	1920	Tc	-
	Horizontal Active Blanking Period	THB	TH-THD	330	TH-THD	Tc	-

Refresh rate 50Hz (Power Saving Mode)



Signal	Item	Symbol	Min.	Typ.	Max.	Unit	Note
DCLK	Frequency	1/Tc	126.35	127.35	128.35	MHz	-
DE	Vertical Total Time	TV	1128	1132	1136	TH	-
	Vertical Active Display Period	TVD	1080	1080	1080	TH	-
	Vertical Active Blanking Period	TVB	TV-TVD	52	TV-TVD	TH	-
	Horizontal Total Time	TH	2240	2250	2260	Tc	-
	Horizontal Active Display Period	THD	1920	1920	1920	Tc	-
	Horizontal Active Blanking Period	THB	TH-THD	330	TH-THD	Tc	-

Refresh rate 50Hz (Power Saving Mode)

Signal	Item	Symbol	Min.	Typ.	Max.	Unit	Note
DCLK	Frequency	1/Tc	121.3	122.26	123.22	MHz	-
DE	Vertical Total Time	TV	1128	1132	1136	TH	-
	Vertical Active Display Period	TVD	1080	1080	1080	TH	-
	Vertical Active Blanking Period	TVB	TV-TVD	52	TV-TVD	TH	-
	Horizontal Total Time	TH	2240	2250	2260	Tc	-
	Horizontal Active Display Period	THD	1920	1920	1920	Tc	-
	Horizontal Active Blanking Period	THB	TH-THD	330	TH-THD	Tc	-

Note (1) The panel can operate at 60Hz normal mode and power saving mode, respectively. All reliability tests are based on specific timing of 60Hz refresh rate. We can only assure the panel's electrical function at power saving mode.

INPUT SIGNAL TIMING DIAGRAM

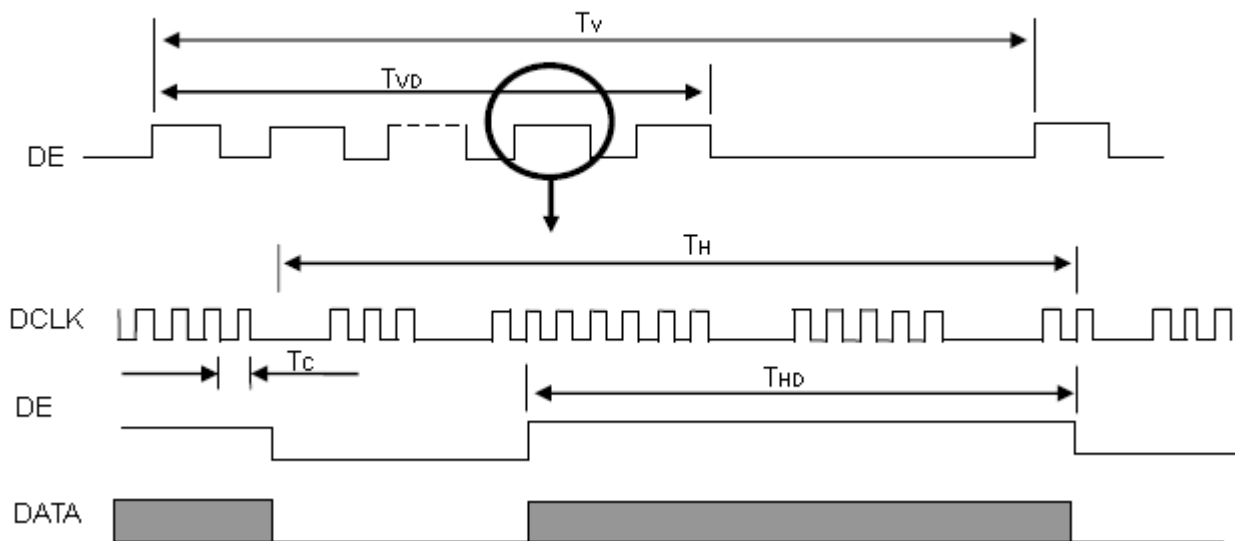



6. Power On/Off Sequence

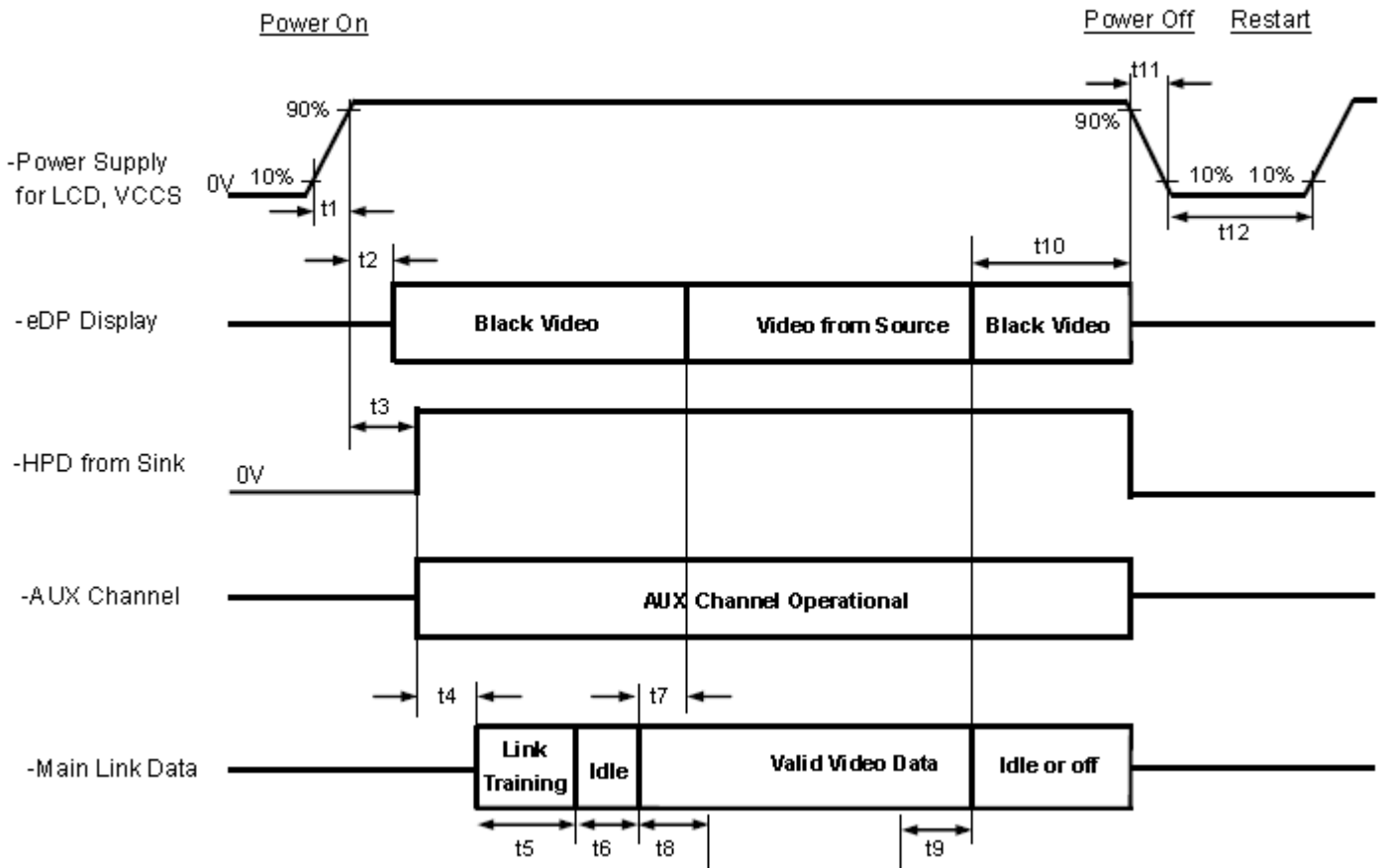

Timing Specifications:

Parameter	Description	Reqd. By	Value		Unit	Notes
			Min	Max		
t1	Power rail rise time, 10% to 90%	Source	0.5	10	ms	-
t2	Delay from LCD,VCCS to black video generation	Sink	0	200	ms	Automatic Black Video generation prevents display noise until valid video data is received from the Source (see Notes:2 and 3 below)
t3	Delay from LCD,VCCS to HPD high	Sink	0	200	ms	Sink AUX Channel must be operational upon HPD high (see Note:4 below)
t4	Delay from HPD high to link training initialization	Source	0	500	ms	Allows for Source to read Link capability and initialize
t5	Link training duration	Source	0	500	ms	Dependant on Source link training protocol



t6	Link idle	Source	0	500	ms	Min accounts for required BS-Idle pattern. Max allows for Source frame synchronization
t7	Delay from valid video data from Source to video on display	Sink	0	50	ms	Max value allows for Sink to validate video data and timing. At the end of T7, Sink will indicate the detection of valid video data by setting the SINK_STATUS bit to logic 1 (DPCD 00205h, bit 0), and Sink will no longer generate automatic Black Video
t8	Delay from valid video data from Source to backlight on	Source	80	500	ms	Source must assure display video is stable *: Recommended by INX. To avoid garbage image.
t9	Delay from backlight off to end of valid video data	Source	50	500	ms	Source must assure backlight is no longer illuminated. At the end of T9, Sink will indicate the detection of no valid video data by setting the SINK_STATUS bit to logic 0 (DPCD 00205h, bit 0), and Sink will automatically display Black Video. (See Notes: 2 and 3 below) *: Recommended by INX. To avoid garbage image.
t10	Delay from end of valid video data from Source to power off	Source	0	500	ms	Black video will be displayed after receiving idle or off signals from Source
t11	VCCS power rail fall time, 90% to 10%	Source	0.5	10	ms	See Note 5 below
t12	VCCS Power off time	Source	500	-	ms	-

Note (1) Please don't plug or unplug the interface cable when system is turned on.

Note (2) The Sink must include the ability to automatically generate Black Video autonomously. The Sink must automatically enable Black Video under the following conditions:

- Upon LCD VCCS power-on (within T2 max)
- When the "NoVideoStream_Flag" (VB-ID Bit 3) is received from the Source (at the end of T9)

Note (3) The Sink may implement the ability to disable the automatic Black Video function, as described in Note (2), above, for system development and debugging purposes.

Note (4) The Sink must support AUX Channel polling by the Source immediately following LCD VCCS power-on without causing damage to the Sink device (the Source can re-try if the Sink is not ready). The Sink must be able to response to an AUX Channel transaction with the time specified within T3 max.

Note (5) The VCCS power rail is recommended to rise and fall linearly. If not, please contact us to conduct risk assessment



7. Optical Specifications

The relative measurement methods of optical characteristics are shown

Item	Symbol	Conditions	Specifications			Unit	Note
			Min.	Typ.	Max.		
Transmittance (w/o APCF, w/o Haze) (w/o WPA)	T%	Viewing normal angle $\theta_x = \theta_y = 0^\circ$	6.24	6.82	--	%	All left side data are based on Innolux's following condition 1.LC : AAS 2.Light Source : C-Light 3.Polar based on Innolux's polar 4.with BS-ITO 5.Machine : DMS 900 6. Driving voltage : VLC dark = 0.2V (just for reference) VLC white = 5V (just for reference) 7. no WPA
Contrast Ratio (w/o WPA)	CR		800	1000	--	--	
Response Time (w/o WPA)	$T_{on} + T_{off}$		--	--	30	ms	
Viewing Angle	Hor.	θ_{x+}	75	80	--	deg.	
		θ_{x-}	75	80	--		
	Ver.	θ_{y+}	75	80	--		
		θ_{y-}	75	80	--		
CF only Color Chromaticity (CIE 1931)	Red	Rx	0.586	0.606	0.626	-	Final CF Chromaticity (w/i OC, w/i ITO) under C light
		Ry	0.316	0.336	0.356	-	
	Green	Gx	0.278	0.298	0.318	-	
		Gy	0.497	0.517	0.537	-	
	Blue	Bx	0.122	0.142	0.162	-	
		By	0.135	0.155	0.175	-	
	White	Wx	0.291	0.311	0.331	-	
		Wy	0.312	0.332	0.352	-	
	NTSC% (x, y)			34.2	44.2	--	

Note (1) Definition of Viewing Angle (θ_x, θ_y):

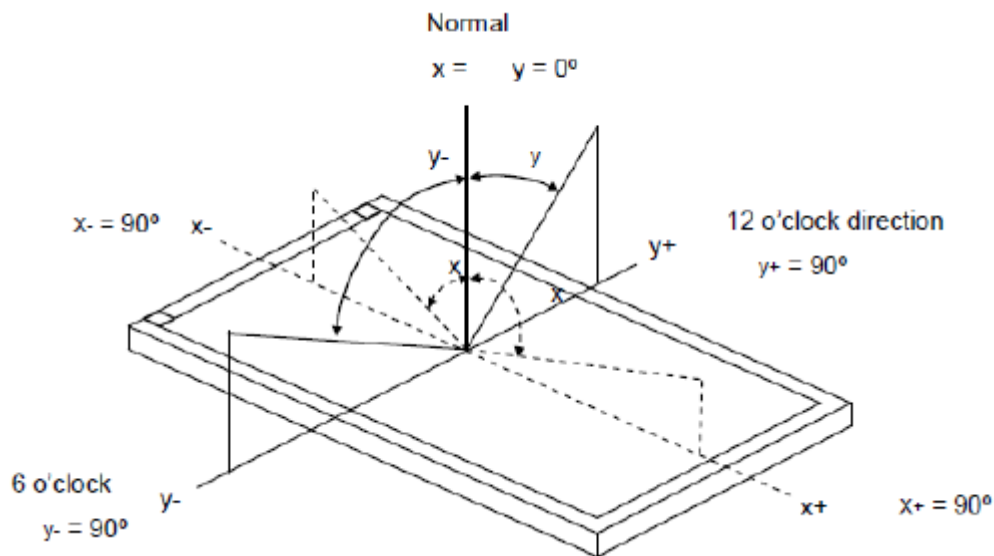

Note (2) Definition of Contrast Ratio (CR):

The contrast ratio can be calculated by the following expression.

$$\text{Contrast Ratio (CR)} = L_{255} / L_0$$

L255: Luminance of gray level 255

L 0: Luminance of gray level 0

$$\text{CR} = \text{CR} (5)$$



CR (X) is corresponding to the Contrast Ratio of the point X at Figure in Note (6).

Note (3) Definition of Response Time :

The response time is defined as the LCD optical switching time interval between “White” state and “Black” state. Rise time (T_r) is the time between photo detector output intensity changed from 10% to 90%. And fall time (T_f) is the time between photo detector output intensity changed from 90% to 10%.

$RT = RT(5)$

RT (X) is corresponding to the Response Time of the point X at Figure in Note (6).

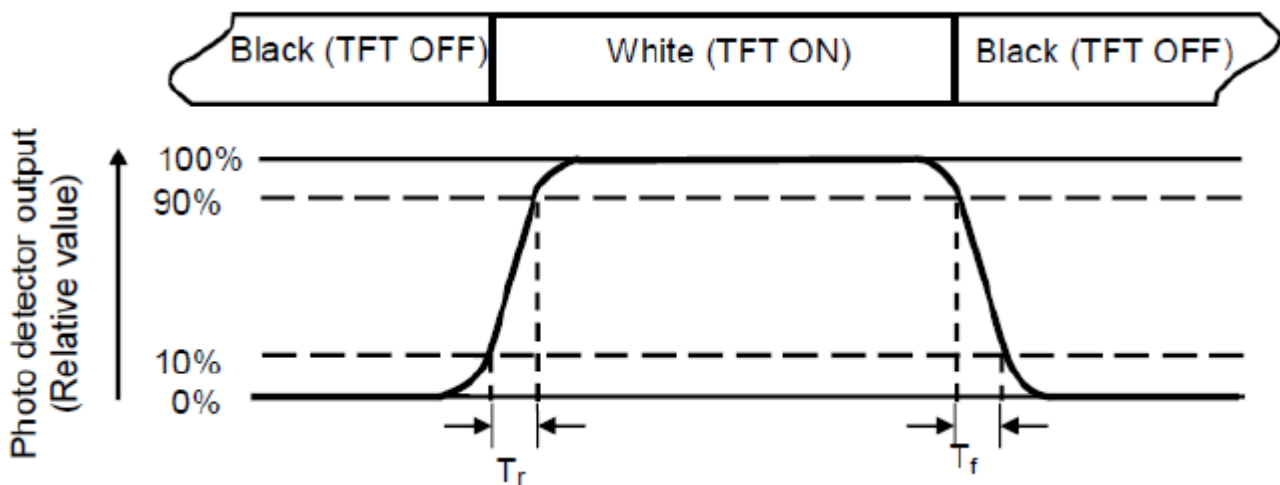

Note (4) Definition of Luminance of White (L_c):

Measure the luminance of gray level 255 at center point

$LC = L(5)$

L (x) is corresponding to the luminance of the point X at Figure in Note (6).

Note (5) Measurement Setup:

The LCD module should be stabilized at given temperature for 40 minutes to avoid abrupt temperature change during measuring. In order to stabilize the luminance, the measurement should be executed after lighting Backlight for 40 minutes in a windless room.

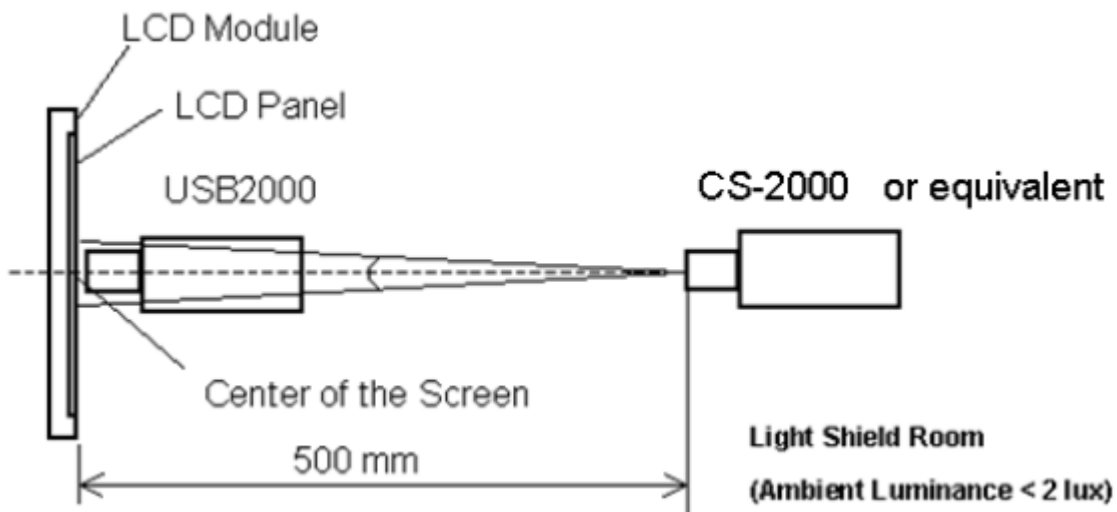

Note (6) Definition of White Variation (ΔW):

Measure the luminance of gray level 255 at 9 points

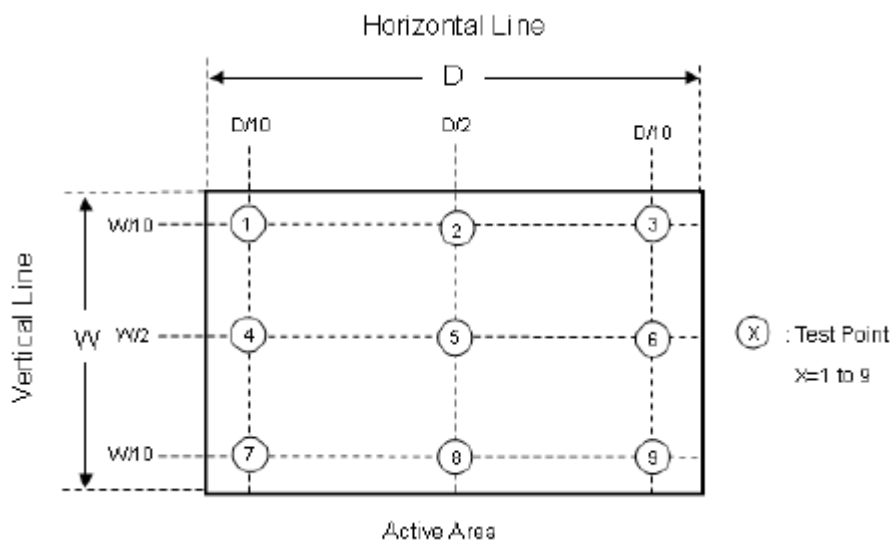

Note (7) The listed optical specifications refer to the initial value of manufacture, but the condition of the specifications after long-term operation will not be warranted.

Note (8) Definition of color gamut (C.G%):

$$C.G\% = \frac{R G B}{R_0 G_0 B_0} \cdot 100\%$$

R_0, G_0, B_0 : color coordinates of red, green, and blue defined by NTSC, respectively.

R, G, B : color coordinates of module on 255 gray levels of red, green, and blue, respectively.

$R_0 G_0 B_0$: area of triangle defined by R_0, G_0, B_0

$R G B$: area of triangle defined by R, G, B

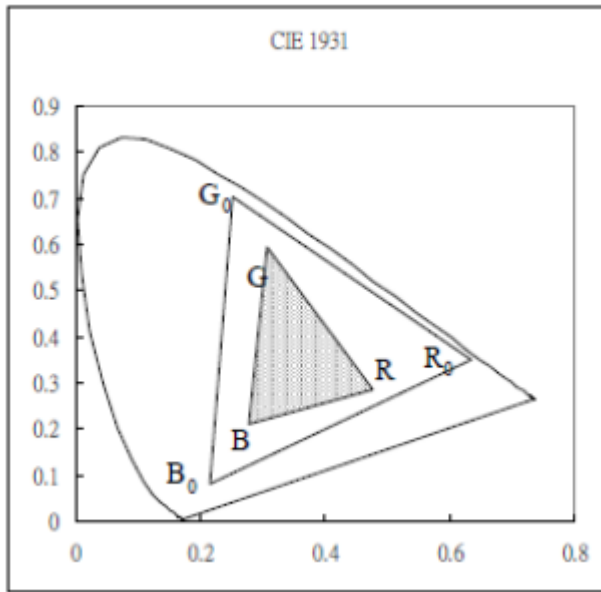

8. Reliability Test Items

No.	Test Item	Test Condition	Check Time
1	High temp storage	T=80°C	96Hrs
2	Low temp storage	T=-30°C	96Hrs
3	High temp operation	T=70°C	96Hrs
4	Low temp operation	T=0°C	96Hrs
5	High temp & high humidity	T=50°C H=90%	96Hrs

Note 1: The test samples have recovery time for 2 hours at room temperature before the function check. In the standard conditions, there is no display function NG issue occurred.

Note 2: After the reliability test, the product only guarantees operation, but don't guarantee all of the cosmetic specification.

Note 3: Under no condensation of dew.



9. Handling Precautions

9.1 Safety

The liquid crystal in the LCD is poisonous. Keep away from your mouth and eyes. If the liquid crystal contacts with your skin, mouse or clothes, use soap to wash it off immediately.

9.2 Handling

- i. The LCD panel is made of very thin glass. Mechanical impact or extrusion to the surface should be prevented.
- ii. The polarizer attached on the display is very easy to be damaged, handle it with special attention.
- iii. To avoid contamination on the display surface, do not touch the display surface with bare hands.
- iv. The transparent electrodes may be disconnected if you use the LCD panel under dew-condensing environment.
- v. The characteristics of the semiconductor devices may be affected when they are exposed to light, possibly resulting in malfunctioning of the ICs. To prevent such malfunctioning of the ICs, make sure the application and the mounting of the panel are designed so that the IC is not exposed to light.

9.3 Static Electricity

Ground soldering iron tips, tools and testers when you operate. Also ground your body when handling the products and store the products in an anti-electrostatic container.

9.4 Storage

Store the products in a dark place where the temperature is within the range of $25\pm 10^{\circ}\text{C}$ and with low humidity (60%RH or less). Do not store the LCD product in an atmosphere containing organic solvents or corrosive gases.

9.5 Cleaning

Do not wipe the polarizer with dry cloth, as it might cause scratching. Wipe the polarizer with a soft cloth soaked with petroleum IPA. Other chemical might damage the panel.



10. QC

10.1 目的

制定 15.6 寸模组产品出货检验标准，明确检验内容和规范；

10.2 范围

适用于康泰科技集团有限公司，使用原装模组、FOG或自购LCD所生产的模组、FOG出货；

10.3 定义

黑白点：显示的点是黑色或者白色，当对比变化时，这些缺陷在大小或强度上没有变化；

亮点：显示中的点（子像素），在显示区域显示为明亮，大小大于 1/2dot，通过 5%的 ND 卡在黑色画面下可见；

碎亮点：在黑画面下看到的发亮的，大小小于 1/2dot 的点；

暗点：显示中的点（子像素），大小大于 1/2dot，在红绿蓝画面的显示区域显示为黑色；

Mura：相对于显示区域的部分背景亮度，部分区域更暗或者更亮的现象（显示画面不均匀）；

二连点：两个相邻的 dot 点；

三连点：三个相邻的 dot 点；

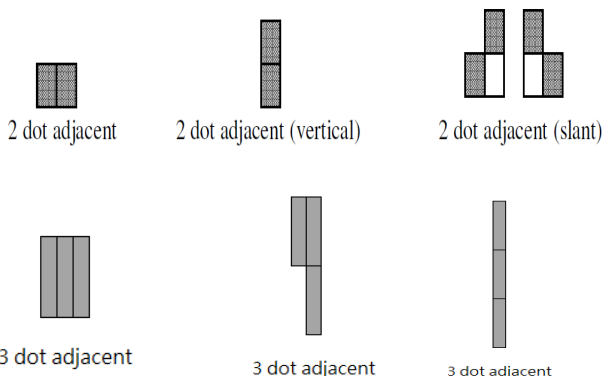
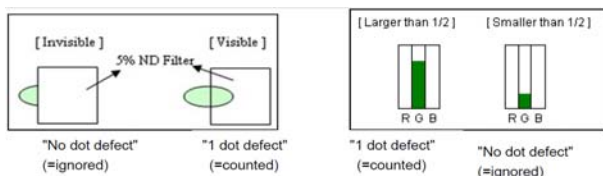

10.4 检验条件

10.4.1 环境要求：温度：25±5℃、湿度：30%–70%RH；

10.4.2 外观检验灯光：20w 荧光灯或等效照度；

10.4.3 检验距离：30cm；

10.4.4 电性检验照度要求：100–200Lux；



10.4.5 外观检验照度要求：500-700Lux；

10.4.6 ND 卡检验要求：ND 放于距 cell 表面 2cm 处，从 30cm 距离检验；

10.4.7 检验角度：做垂直方向 $\pm 45^\circ$ ，水平方向 $\pm 45^\circ$ 夹角检验；

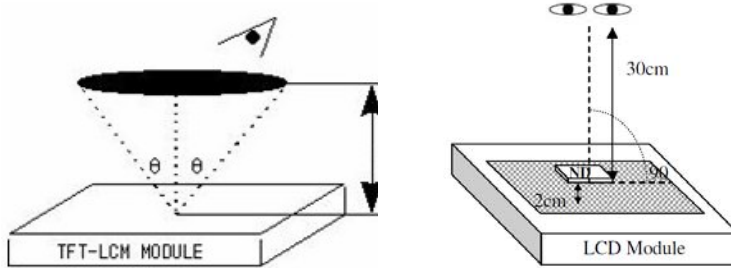

10.4.8 显示区域划分：将显示区长度和宽度方向均匀分为 4 等分，中间 2/4 区域为 I 区，四周为 0 区，见下图：

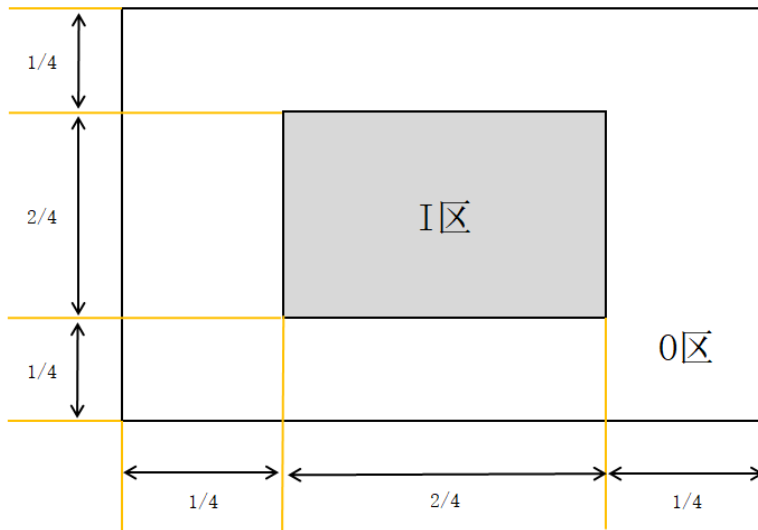



10.5 电性检测

检验项目	检验标准																							
	A0 规			A1 规			A2 规			A3 规			A4 规			B 规								
	I 区	O 区	总数	I 区	O 区	总数	I 区	O 区	总数	I 区	O 区	总数	I 区	O 区	总数	I 区	O 区	总数						
亮点	N≤0			N≤2			N≤4			N≤8			N≤10			不计								
二溢亮点	N≤0			N≤0			N≤1			D5≥			N≤8			N≤10			不计					
三溢亮点	N≤0			N≤0			N≤0			8mm			N≤8			N≤10			不计					
暗点	N≤1	N≤3, D5 ≥ 10mm	N≤3, D5 ≥ 10mm	N≤8, D5 ≥10mm			N≤5, D5 ≥			N≤7, D5 ≥			N≤10			N≤20			不计					
二溢暗点	N≤0			N≤1			10mm			N≤2, D5 ≥8mm			8mm			N≤7			N≤20			不计		
三溢暗点	N≤0			N≤0			N≤1			N≤1			N≤7			N≤20			不计					
亮点+暗点	N≤3, D5 ≥10mm			N≤8, D5 ≥10mm			N≤7, D5 ≥8mm			/			/			/			/					
脏亮点	10%ND 逆指不可见, 无视			8%ND 逆指不可见, 无视			不计 (满屏良不可)			不计 (满屏良不可)			不计 (满屏良不可)			不计 (满屏良不可)			不计					
点状异物点, 黑白点	D≤0.15mm, 数量 N 不计; 0.15mm<D≤0.3mm, N≤3, 间距≥10mm; 0.3mm<D≤0.4mm, N≤1			D≤0.3mm, 数量 N 不计; 0.3mm<D≤0.8mm, N≤3, 间距≥10mm;			D≤0.3mm, 数量 N 不计; 0.3mm<D≤0.8mm, N≤3, 间距≥10mm; 0.8mm<D≤1.2mm, N≤1;			/			/			/			/					
线状异物	W≠0.1mm, L≠0.3mm, 不计; W≠0.1mm, L≠2mm, N≤2, D5≥10mm;			W≠0.1mm, 不计; 0.1mm<W≠0.3mm, 0.8mm<L≠4mm, N≤3;			W≠0.1mm, 不计; 0.1mm<W≠0.3mm, 0.8mm<L≠8mm, N≤3;			W≠0.1mm, 不计; 0.1mm<W≠0.3mm, 0.8mm<L≠4mm, N≤5;			/			/			/					
POL 气泡	D≤0.2mm, 不计; 0.2mm<D≤0.8mm, N≤2, D5≥10mm 线状按线状异物判定			线状及点状不良参照异物 标准; 边缘气泡不进入 BM 区 1/2 为 OK			线状及点状不良参照异物 标准; 边缘气泡不进入显示区为 OK			/			/			/			/					
Mura	1. 全视角判定, 距离 50mm-80mm 不可见为 OK 2. 轻微 mura 按 10%ND 逆指 不可见为 OK			MOS 和次阶图案不可见, 漏 图案可见, 不计			8%ND 逆指不可见			/			/			/			/					
功能缺陷	显示异常、断线(横线、竖线等)、无品、等影响功能的不良不可有																							



10.6 外观检验

检验项目	图示	检验标准					
		A0 级	A1 级	A2 级	A3 级	A4 级	B 级
FAD 区角落破损		$X \leq 1.5mm, Y \leq 1.5mm, Z \leq T, N \leq 2$ 不伤及线路, 显示正常			不伤及线路, 显示正常		
FAD 区边缘破损		$T \leq 0.5, X \leq 2.0, Z \leq T, N \leq 2$ 不伤及线路, 显示正常			不伤及线路, 显示正常		
非 FAD 区角落破损		$X \leq 1.5mm, Y \leq 1.5mm, Z \leq T, N \leq 2$, 不伤及线路, 显示正常			不伤及线路, 显示正常		
非 FAD 区边缘破损		$X \leq 1.5mm, Y \leq 0.5mm, Z \leq T, N$ 不计, 不伤及线路, 显示正常			不伤及线路, 显示正常		
表面点	无图	$D \leq 0.3mm$, 数量 N 不计; $0.5mm < D \leq 0.8mm, N \leq 5$, 间距 $\geq 10mm$;			不计		
表面划伤	无图	$W \leq 0.1mm$, 不计; $0.1mm < W \leq 0.2mm, 0.5mm < L \leq 4mm, N \leq 5$;			不计		
FPC/PCB	无图	<ol style="list-style-type: none"> 定位孔破损不可有 FPC 死折不可有 元件脱落不可有 元件虚焊、漏锡等焊接不良不可有 金手指折、裂不可有 元件卡不到位不可有 FPC 翘起对位偏移不可有 FPC 上表面脱胶脱落异常不可有 指套不能松动, 不影响指按 			<ol style="list-style-type: none"> 元件脱落, 不可有 元件虚焊、漏锡等焊接不良, 不可有 		
保护膜	无图	<ol style="list-style-type: none"> 划伤不可有, 其他划伤、印记等无视 易撕胶按图粘贴 			看保护膜		
裂纹		不可有					

1. W : Width

2. L : Length

3. D : Average Diameter

4. N : Count

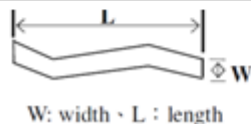

10.7 质保期限

10.7.1 保修 12 个月（如有合同，以合同为准）。

end.